

8 7 6 5 4 3 2 1

REVISIONS		DATE	APPROVED
REV.	DESCRIPTION		

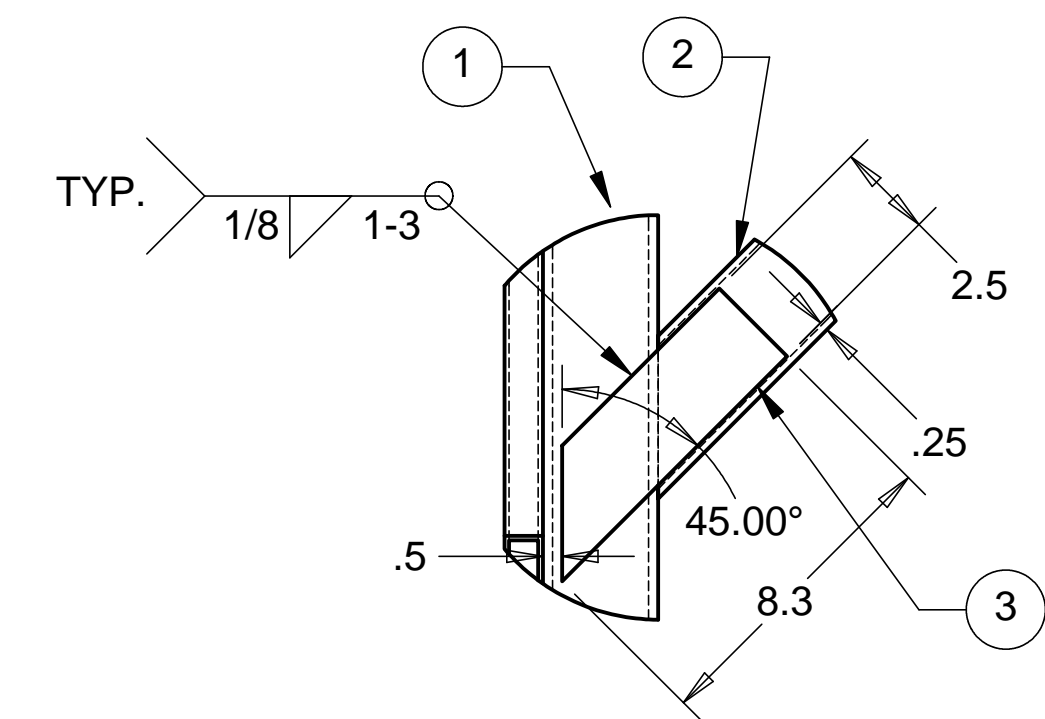

DETAIL A
SCALE 1 : 5

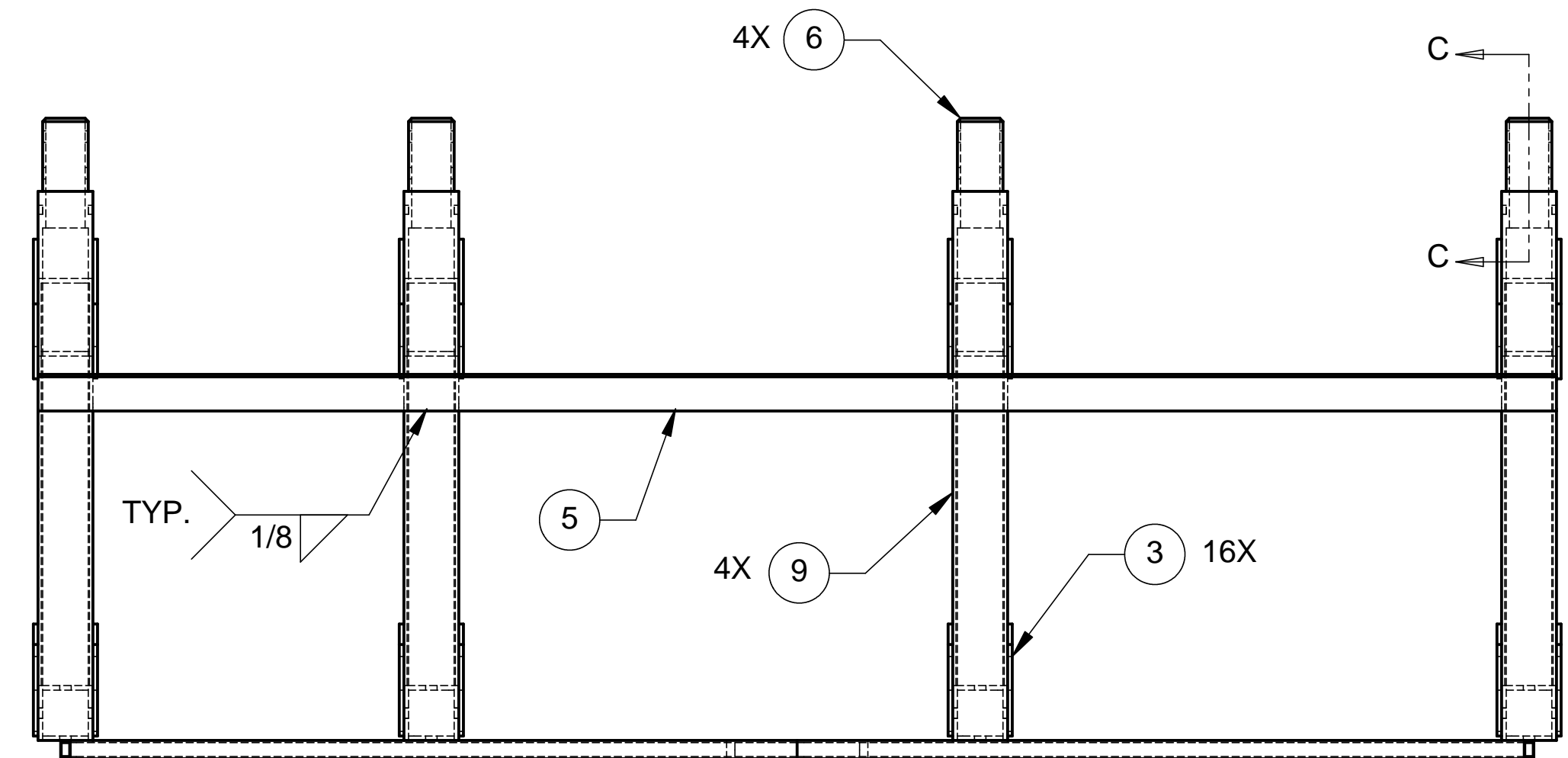
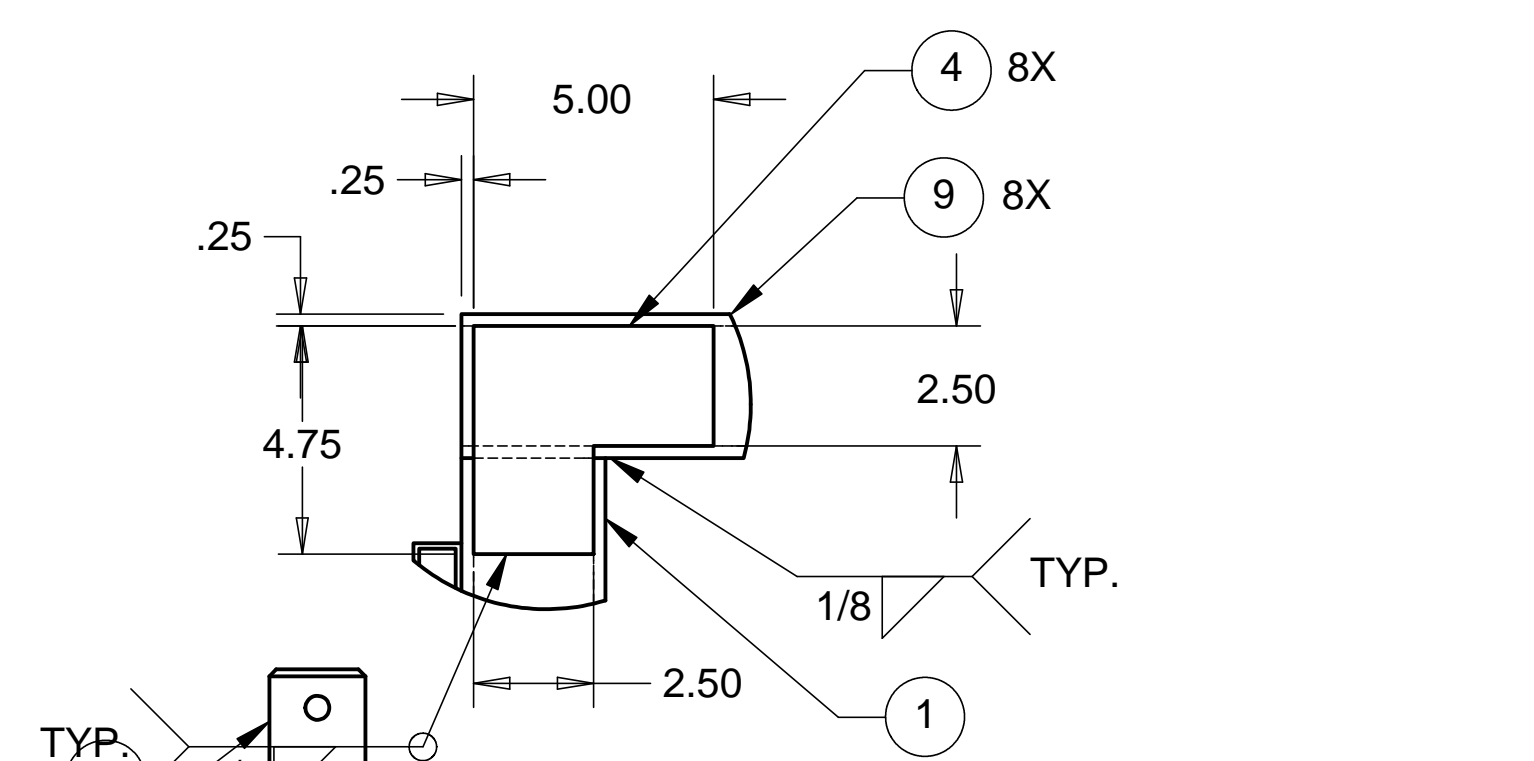

DETAIL B
SCALE 1 : 4

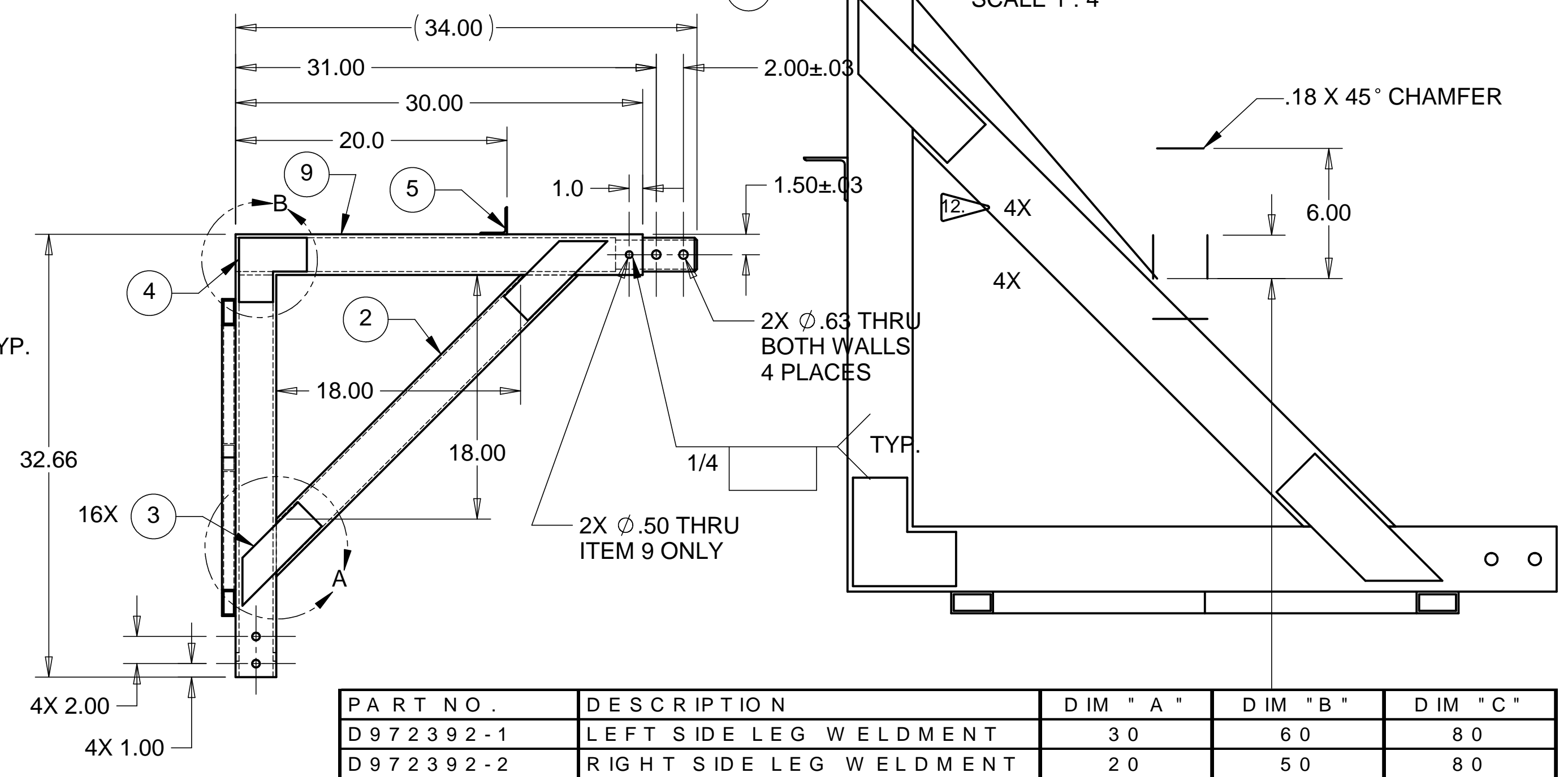
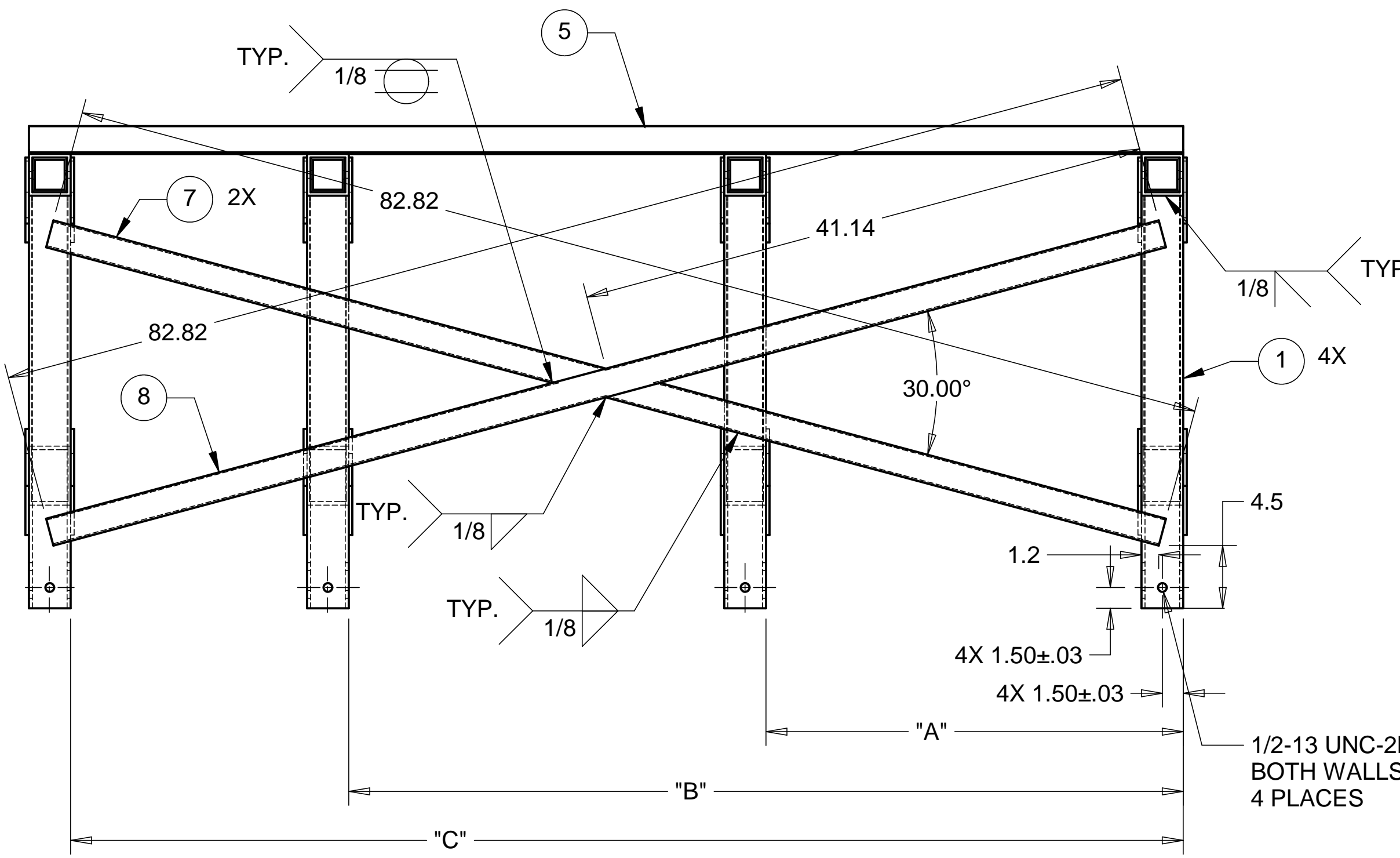

PART NO.	DESCRIPTION	DIM "A"	DIM "B"	DIM "C"
D972392-1	LEFT SIDE LEG WELDMENT	30	60	80
D972392-2	RIGHT SIDE LEG WELDMENT	20	50	80

ITEM NO.	QTY.	DESCRIPTION	MATERIAL
1	4	TUBING, 3 X 3 X .25 WALL	A36 STEEL
2	4	TUBING, 3 X 3 X .18 WALL	A36 STEEL
3	16	1/8" THK GUSSET PLATE	1010 STEEL
4	8	1/8" THK GUSSET PLATE	1010 STEEL
5	1	ANGLE, 2 X 2 X 1/4" THK	A36 STEEL
6	4	TUBING, 2 1/2 X 2 1/2 X .25 WALL	A36 STEEL
7	2	TUBING, 2 X 1.0 X .12 WALL	A36 STEEL
8	1	TUBING, 2 X 1.0 X .12 WALL	A36 STEEL
9	4	TUBING, 3 X 3 X .25 WALL	A36 STEEL

NOTES: UNLESS OTHERWISE SPECIFIED

- ALL DIMENSIONS IN INCHES
- DIMENSIONS AND TOLERANCING PER ASME Y14.5M-1994
- SURFACE TEXTURE PER ANSI/ASME B 46.1-1985
- REMOVE ALL BURRS AND BREAK SHARP EDGES TO A MAXIMUM OF .015
- ALL INSIDE CORNERS TO BE .015 RADIUS MAX
- COUNTERSINK 82 DEGREES ALL TAPPED HOLES TO MAJOR DIAMETER
- COUNTERSINK 82 DEGREES APPROXIMATELY .015 DEEP ALL DRILLED HOLES
- PARTS TO BE THOROUGHLY CLEANED TO REMOVE ALL OIL, GREASE, DIRT AND CHIPS
- PART NUMBER (DRAWING NO. PLUS DASH NO. PLUS SERIAL NO.) TO BE CLEARLY MARKED ON THE PART ITSELF.
- PART WEIGHS 340.5 Lbs.
- PAINT PART USING SHERMAN WILLIAMS MEDIUM TEXTURED BEIGE (D13 POLANE T-PLUS, POLYURETHANE ENAMEL, F63 SERIES, #SW-F63TX-H-1651-5864).

GRIND ITEM(S) 6 TO FIT INTO ITEM(S) 9 AND PART D972393.

PARTS LIST			
UNLESS OTHERWISE SPECIFIED: DIMENSIONS ARE IN INCHES -TOLERANCES-		CAD GENERATED DRAWING, DO NOT MANUALLY UPDATE DO NOT SCALE DRAWING	
DECIMALS .XX = +/- .06 .XXX = +/- .030	ANGULAR = +/- .30° SURFACE FINISH = 250	<p>HYTEC, INC</p> <p>TITLE BSC ROLLER ASSEMBLY UPPER LEG WELDMENT</p>	
FINISH	SIGNATURE	DATE	DWG. NO.
	DESIGNED W. K. MILLER	2/9/98	D972392
	DRAWN W. K. MILLER	2/9/98	
PART NO. D972392-1	CHECKED HARRY SALAZAR	-	SIZE D
	ENGR. T. THOMPSON	-	SHEET NO. 1 of 1
	APPROVED T. THOMPSON	-	REVISION
		SCALE 1/8	

8 7 6 5 4 3 2 1