

8 7 6 5 4 3 2 1

REVISIONS			
REV.	DESCRIPTION	DATE	APPROVED

D

D

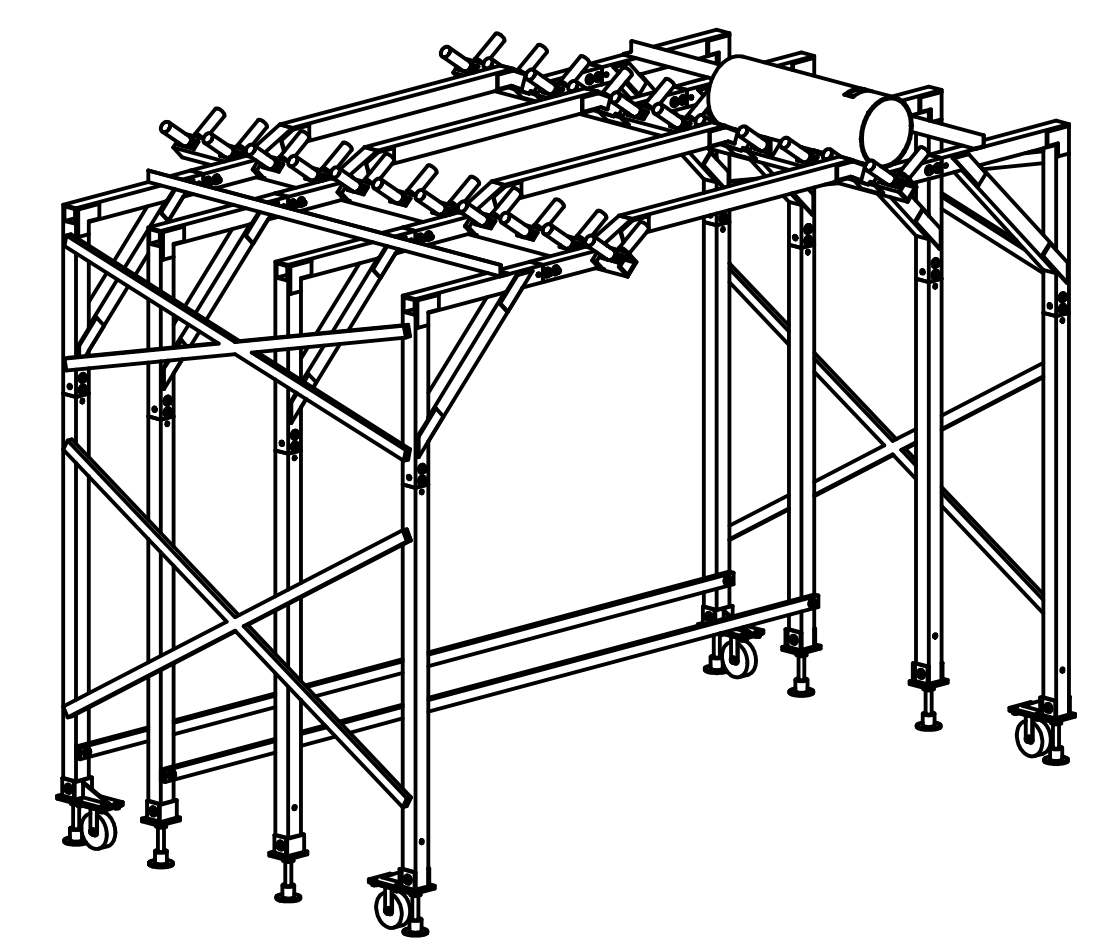

C

C

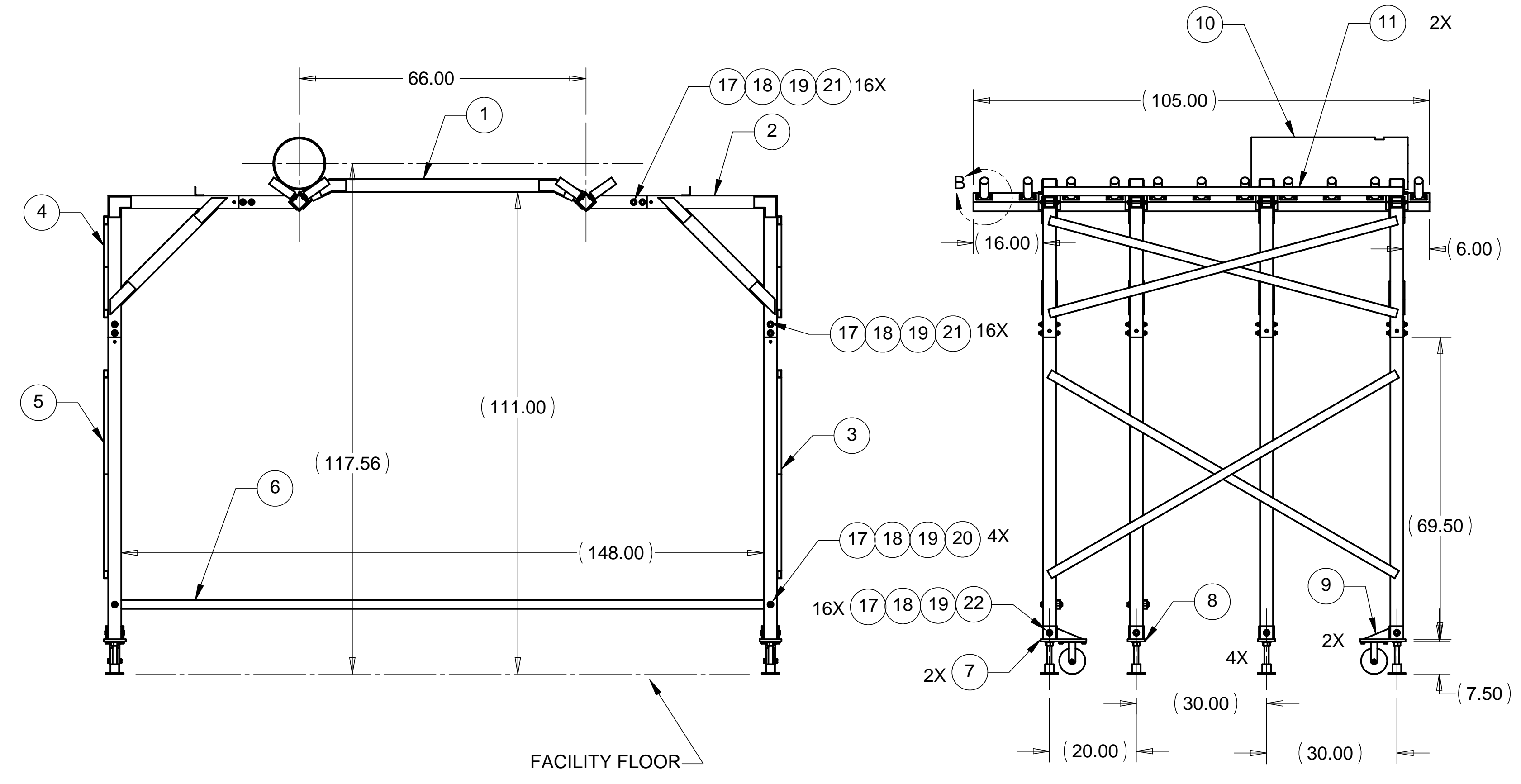

B

B

FACILITY FLOOR

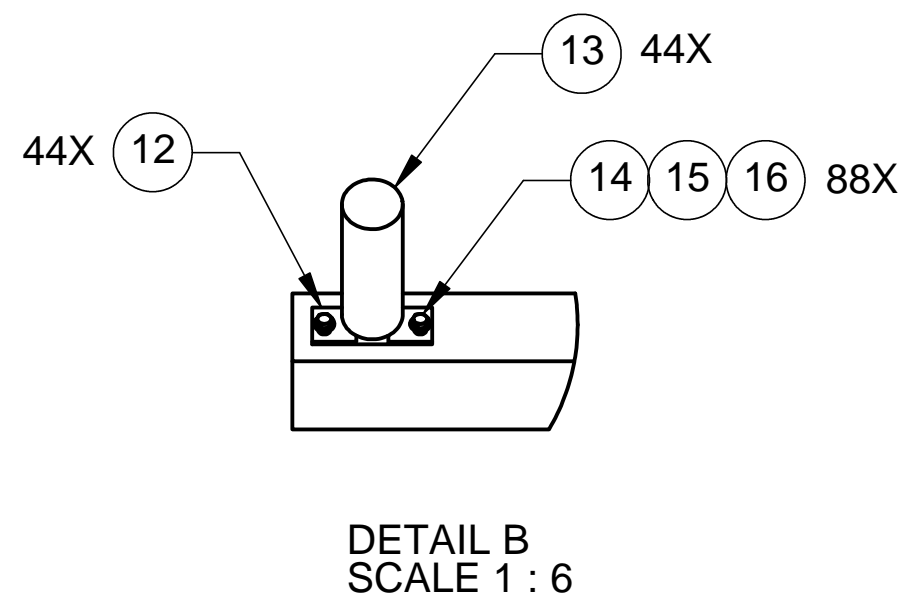

ITEM NO.	QTY.	PART NO.	DESCRIPTION
1	1	D972393-1	MIDDLE STRUCTURE WELDMENT
2	1	D972392-1	LEFT UPPER LEG WELDMENT
3	1	D972391-1	LEFT LOWER LEG WELDMENT
4	1	D972392-2	RIGHT UPPER LEG WELDMENT
5	1	D972391-2	RIGHT LOWER LEG WELDMENT
6	1	D972439-1	HORIZONTAL LEG TRUSS
7	2	D972394-1	CASTOR FOOT ASSEMBLY - SWIVEL CASTOR
8	4	D972395-1	ADJUSTABLE FOOT ASSEMBLY
9	2	D972394-2	CASTOR FOOT ASSEMBLY - FIXED CASTOR
10	1	D972444-1	TUBE JIG
11	2	D972445-1	TUBE SPACING JIG
12	44	D972443-1	ROLLER MOUNTING PLATE
13	44	1.340-A49-S53	ROLLER, 1.90 O.D. X 6.0 RL, INTERROLL CORP.
14	88	STD HARDWARE	HEX HEAD SST BOLT, 1/4-28 UNF-2A X .75 LONG
15	88	STD HARDWARE	WASHER, SST 1/4" FLAT
16	88	STD HARDWARE	LOCKWASHER, SST 1/4"
17	88	STD HARDWARE	WASHER, SST 1/2" FLAT
18	88	STD HARDWARE	LOCKWASHER, SST 1/2"
19	72	STD HARDWARE	SST HEX NUT, 1/2-13 UNC-2B
20	4	STD HARDWARE	HEX HEAD SST BOLT, 1/2-13 UNC X 5.0 LONG
21	32	STD HARDWARE	HEX HEAD SST BOLT, 1/2-13 UNC X 4.0 LONG
22	16	STD HARDWARE	HEX HEAD SST BOLT, 1/2-13 UNC X .75 LONG

A

A

NOTES: UNLESS OTHERWISE SPECIFIED

- ALL DIMENSIONS IN INCHES
- DIMENSIONS AND TOLERANCING PER ASME Y14.5M-1994
- SURFACE TEXTURE PER ANSI/ASME B 46.1-1985
- REMOVE ALL BURRS AND BREAK SHARP EDGES TO A MAXIMUM OF .015
- ALL INSIDE CORNERS TO BE .015 RADIUS MAX
- COUNTERSINK 82 DEGREES ALL TAPPED HOLES TO MAJOR DIAMETER
- COUNTERSINK 82 DEGREES APPROXIMATELY .015 DEEP ALL DRILLED HOLES
- PARTS TO BE THOROUGHLY CLEANED TO REMOVE ALL OIL, GREASE, DIRT AND CHIPS
- PART NUMBER (DRAWING NO. PLUS DASH NO. PLUS SERIAL NO.) TO BE CLEARLY MARKED ON THE PART ITSELF.
- PART WEIGHS 2057 Lbs.
- STAMP ALL MATING ASSEMBLY PIECES.

UNLESS OTHERWISE SPECIFIED: DIMENSIONS ARE IN INCHES -TOLERANCES-		CAD GENERATED DRAWING, DO NOT MANUALLY UPDATE DO NOT SCALE DRAWING		HYTEC, INC TITLE BSC ROLLER SYSTEM ASSEMBLY	
DECIMALS .XX = +/- .06 .XXX = +/- .030	ANGULAR = +/- .30° SURFACE FINISH = 250	SIGNATURE	DATE		
FINISH	DESIGNED	W. K. MILLER	2/8/98	DWG. NO.	D972390
PART NO. D972390-1	DRAWN	W. K. MILLER	2/8/98	SIZE	D
	CHECKED	HARRY SALAZAR	-	SHEET NO.	1 of 1
	ENGR.	T. THOMPSON	-	REVISION	
	APPROVED	T. THOMPSON	-	SCALE	1/16

8 7 6 5 4 3 2 1