

8

7

6

5

4

3

2

1

| REVISIONS |             |      |          |
|-----------|-------------|------|----------|
| REV.      | DESCRIPTION | DATE | APPROVED |
|           |             |      |          |
|           |             |      |          |
|           |             |      |          |

D

D

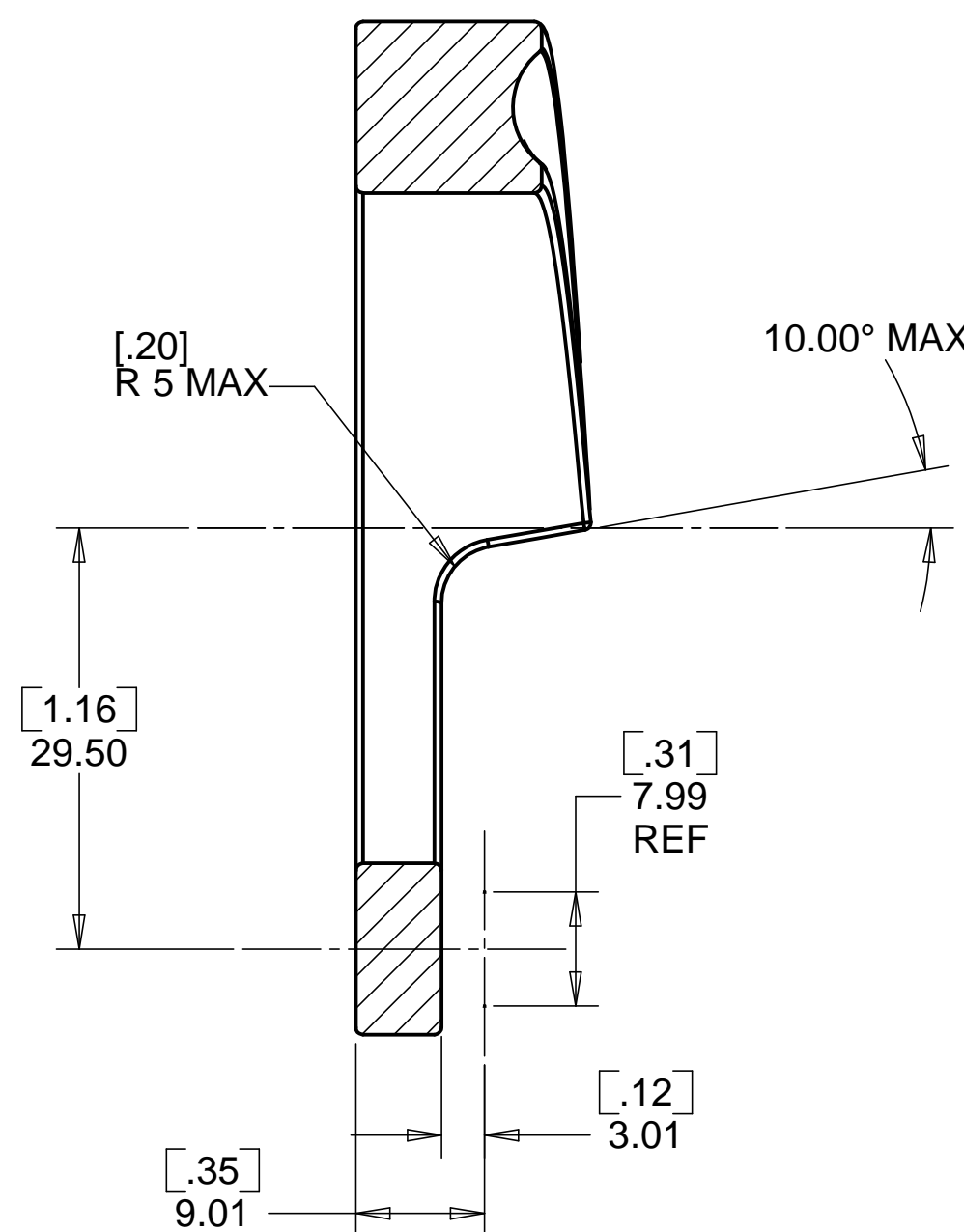

SECTION A-A  
SCALE 2 : 1

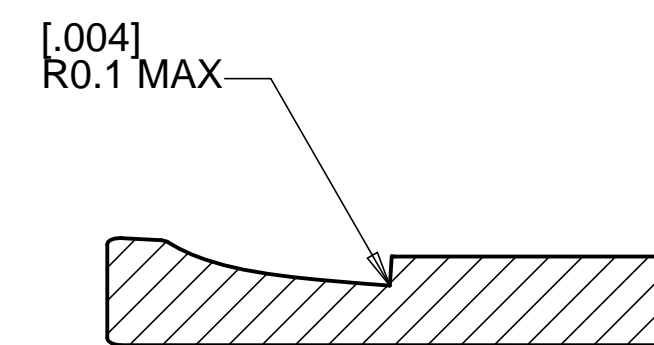
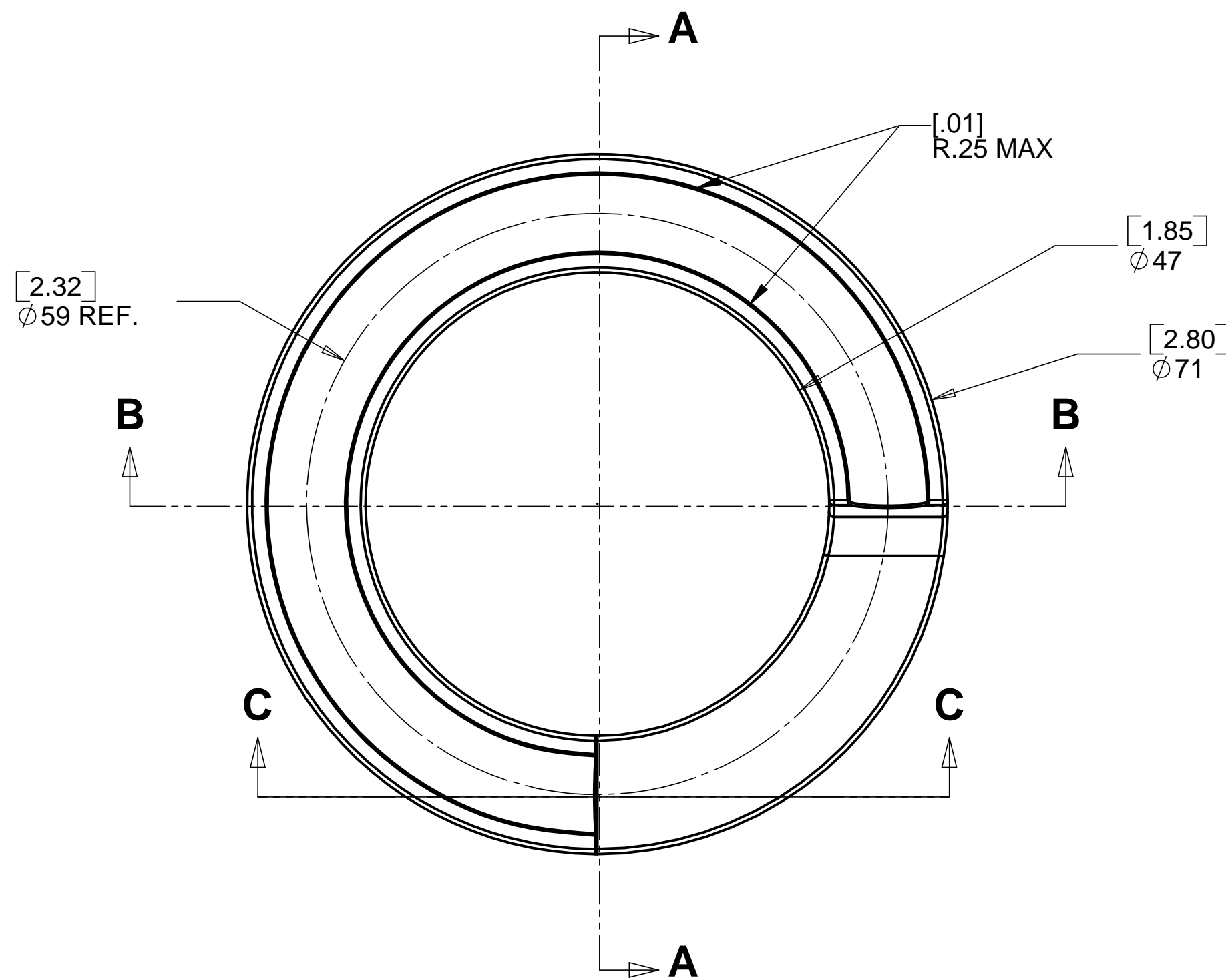

SECTION C-C  
SCALE 2 : 1

270° (3/4 TURN) HELICOIDAL PATH,  
Ø59.00 mm 14.00 mm PITCH

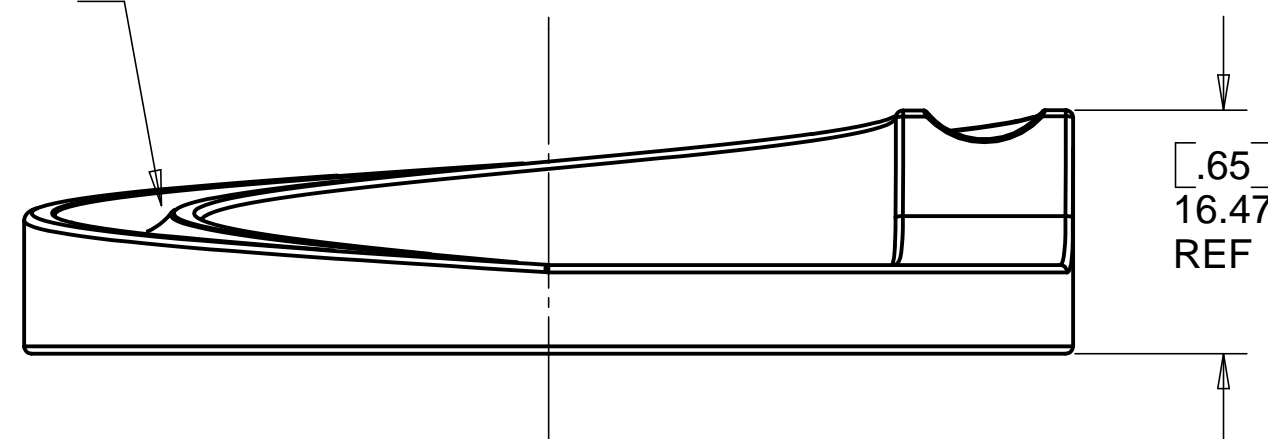

SECTION B-B  
SCALE 2 : 1

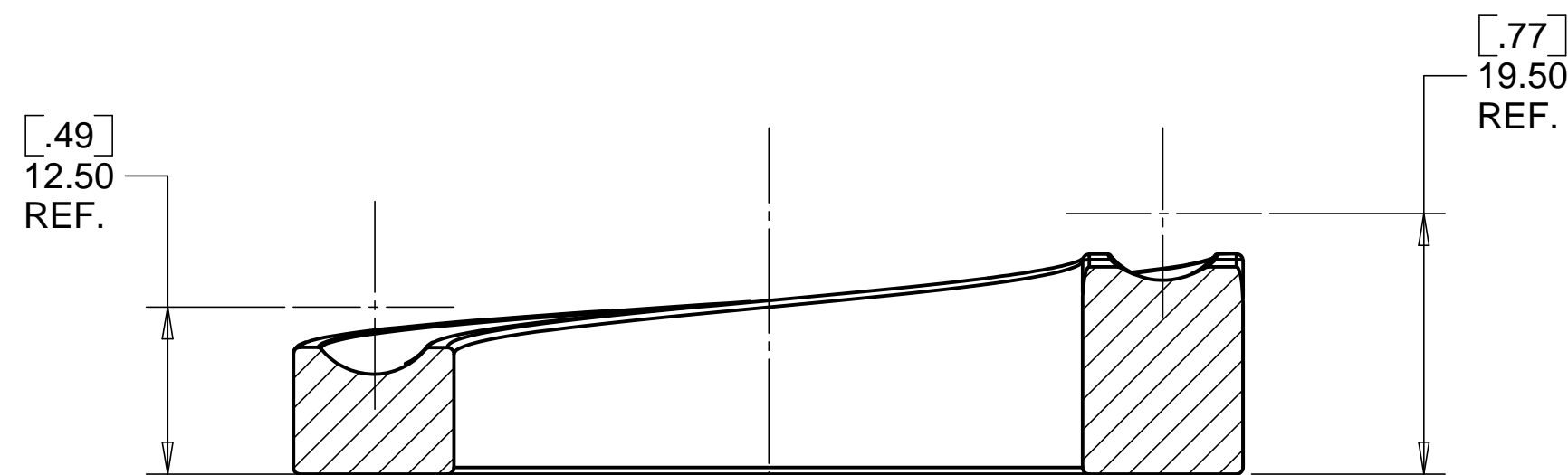

- NOTES:  
 1. QTY: 10  
 2. ALL DIM IN mm.  
 3. BREAK ALL EDGES R0.50mm [0.019] MAX UNLESS OTHERWISE SPECIFIED.  
 4. MATERIALS, PROCESS, POST CURE, CLEANING, HANDLING AND PACKAGING TO ADHERE TO ULTRA-HIGH VACUUM STANDARDS AND ATTACHED SPECIFICATION #HYTEC-TS-LIGO-06.

| PARTS LIST  |  |   |                    |
|---|--|---|--------------------|
| UNLESS OTHERWISE SPECIFIED:<br>DIMENSIONS ARE IN INCHES<br>-TOLERANCES- |  | CAD GENERATED DRAWING,<br>DO NOT MANUALLY UPDATE<br>DO NOT SCALE DRAWING                  |                    |
| DECIMALS<br>.XX = +/- .03<br>.XXX = +/- .010                            | ANGULAR = +/- .30°<br>SURFACE FINISH = 250 | <p><b>HYTEC, INC</b></p> <p>TITLE<br/>LIGO ISOLATION SYSTEM<br/>LEFT COIL SPRING SEAT</p> |                    |
| FINISH  | SIGNATURE                                  | DATE  | DWG. NO.           |
|   | ERIC PONSLET                               | 5-28-97   |                    |
|   | W K MILLER                                 | 7-29-98   | SIZE SHEET NO.     |
|   | T. THOMPSON                                | 7-30-98   | D972220 D 1 of 1   |
| PART NO.<br><b>D97220-1</b>   | ENGR.<br>T. THOMPSON                       | 7-30-98   | SCALE 2/1 REVISION |
|   | APPROVED<br>T. THOMPSON                    | 7-30-98   |                    |

A

8

7

6

5

4

3

2

1

A