

8

7

6

5

4

3

2

1

REVISIONS			
REV.	DESCRIPTION	DATE	APPROVED

D

D

C

C

B

B

A

A

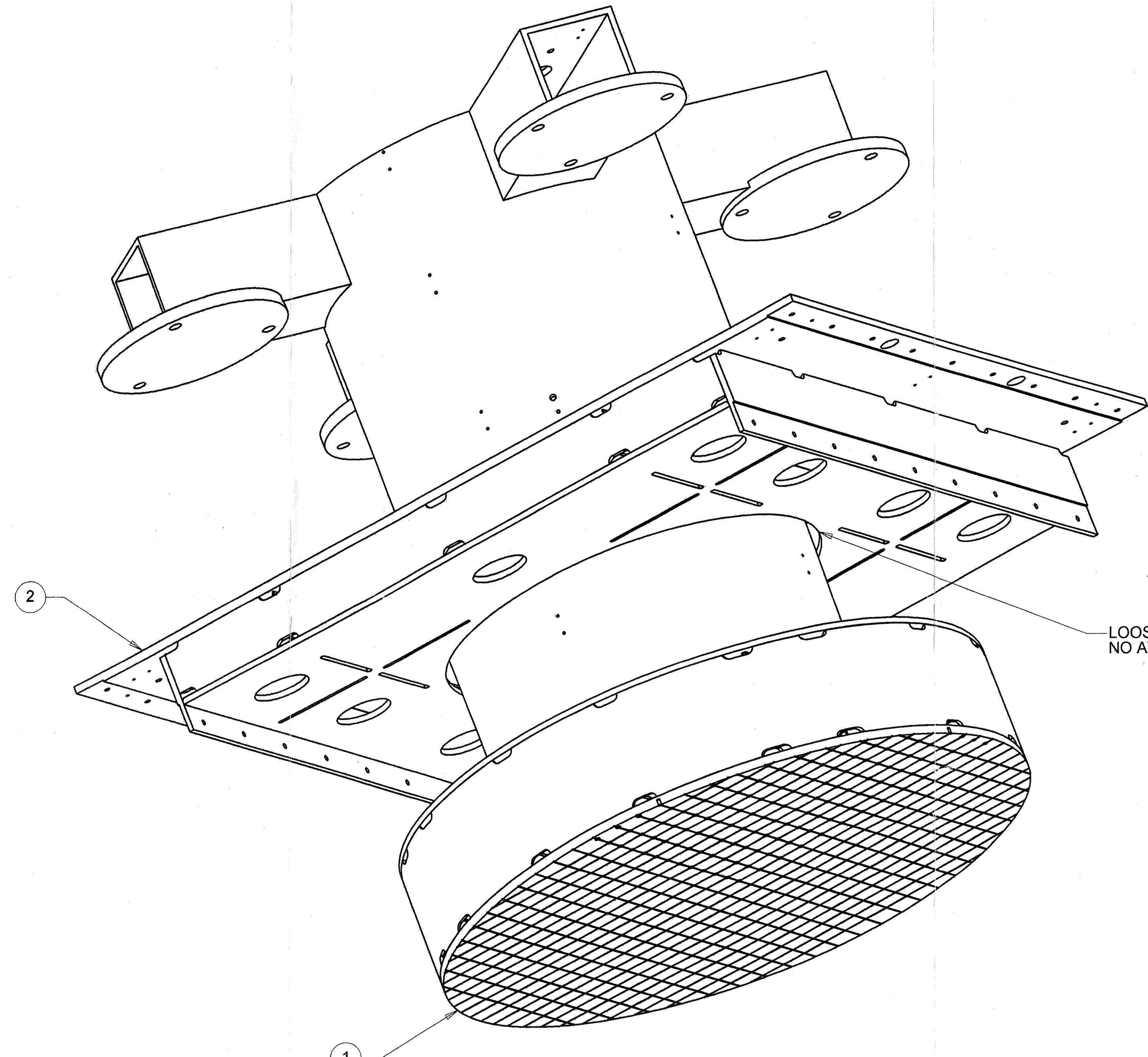

LOOSE FIT  
NO ATTACHMENT

ASSEMBLE ITEMS 1 & 2 PRIOR TO FINAL WELDING OF ITEM 1  
SEE LIG-12006 SHEET D3 NOTE 1

**PRELIMINARY**

ITEM NO.	QTY.	DESCRIPTION	MATERIAL
1	1	BSC DOWNTUBE WELDMNT, LIG-12006-1	
2	1	BSC SUPPORT TABLE WELDMNT, LIG-12011-1	

PARTS LIST			
UNLESS OTHERWISE SPECIFIED: DIMENSIONS ARE IN INCHES -TOLERANCES-	DECIMALS	ANGULAR = +/- .30°	CAD GENERATED DRAWING. DO NOT MANUALLY UPDATE DO NOT SCALE DRAWING
	XX = +/- .03	SURFACE FINISH = 250	
FINISH	SIGNATURE	DATE	<b>HYTEC, INC</b> TITLE LIGO BSC DOWNTUBE/SUPPORT TABLE ASSEMBLY
DESIGNED	ROGER L. SMITH	5-28-97	
DRAWN	ROGER L. SMITH	5-28-97	
CHECKED	HARRY SALAZAR	7-14-97	
ENGR.	T. THOMPSON	7-14-97	
APPROVED	T. THOMPSON	7-14-97	DWG. NO.
PART NO.	D9722210-1		SIZE
			SHEET NO.
			D 1 of 1
			REVISION
			SCALE NONE

8

7

6

5

4

3

2

1