

8

7

6

5

4

3

2

1

REV	DESCRIPTION	DATE	APPROVED
A	SEE ECR# D972160-A FOR CHANGE LIST	05/11/99	T. THOMPSON

D

D

C

C

B

B

A

A

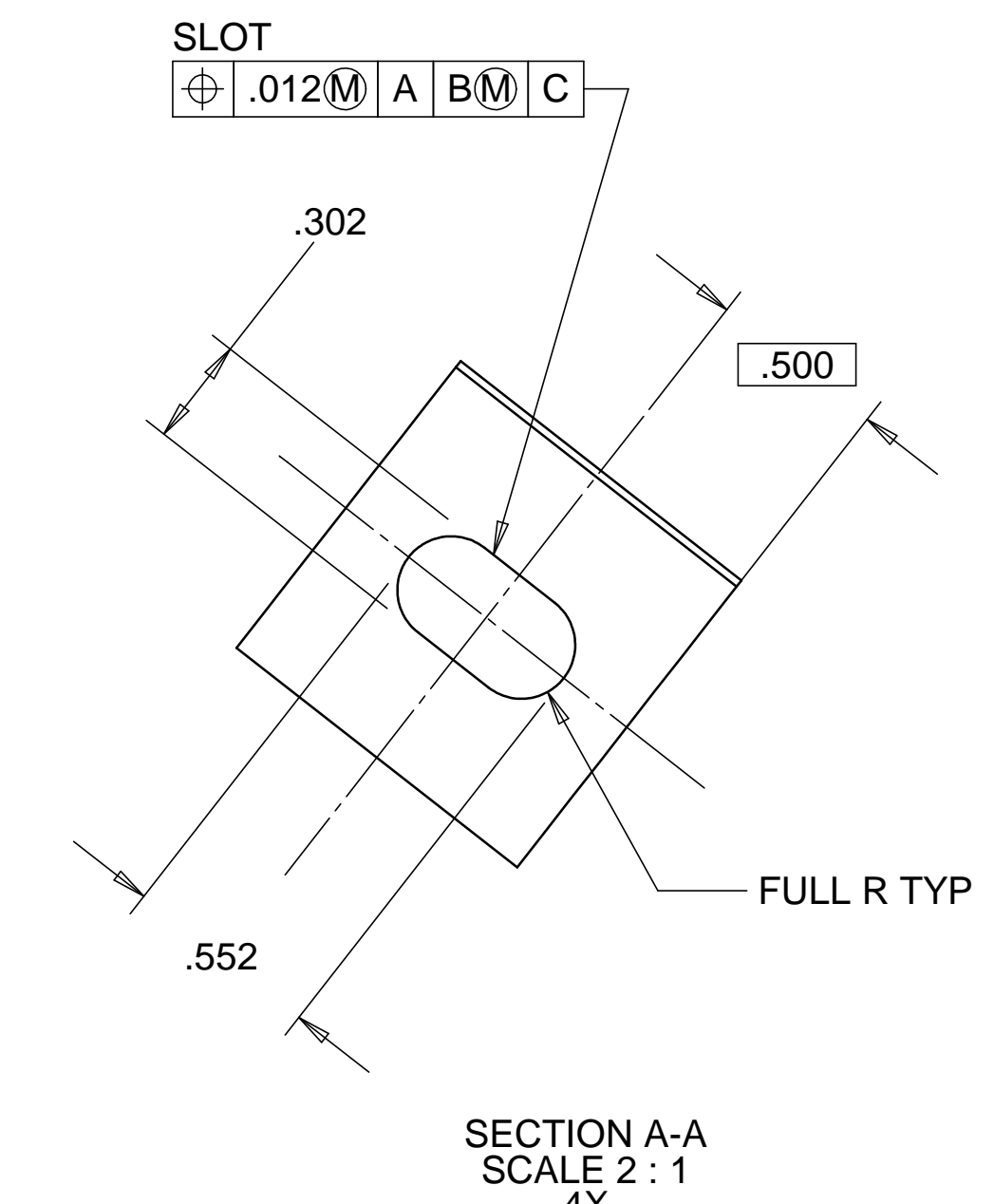
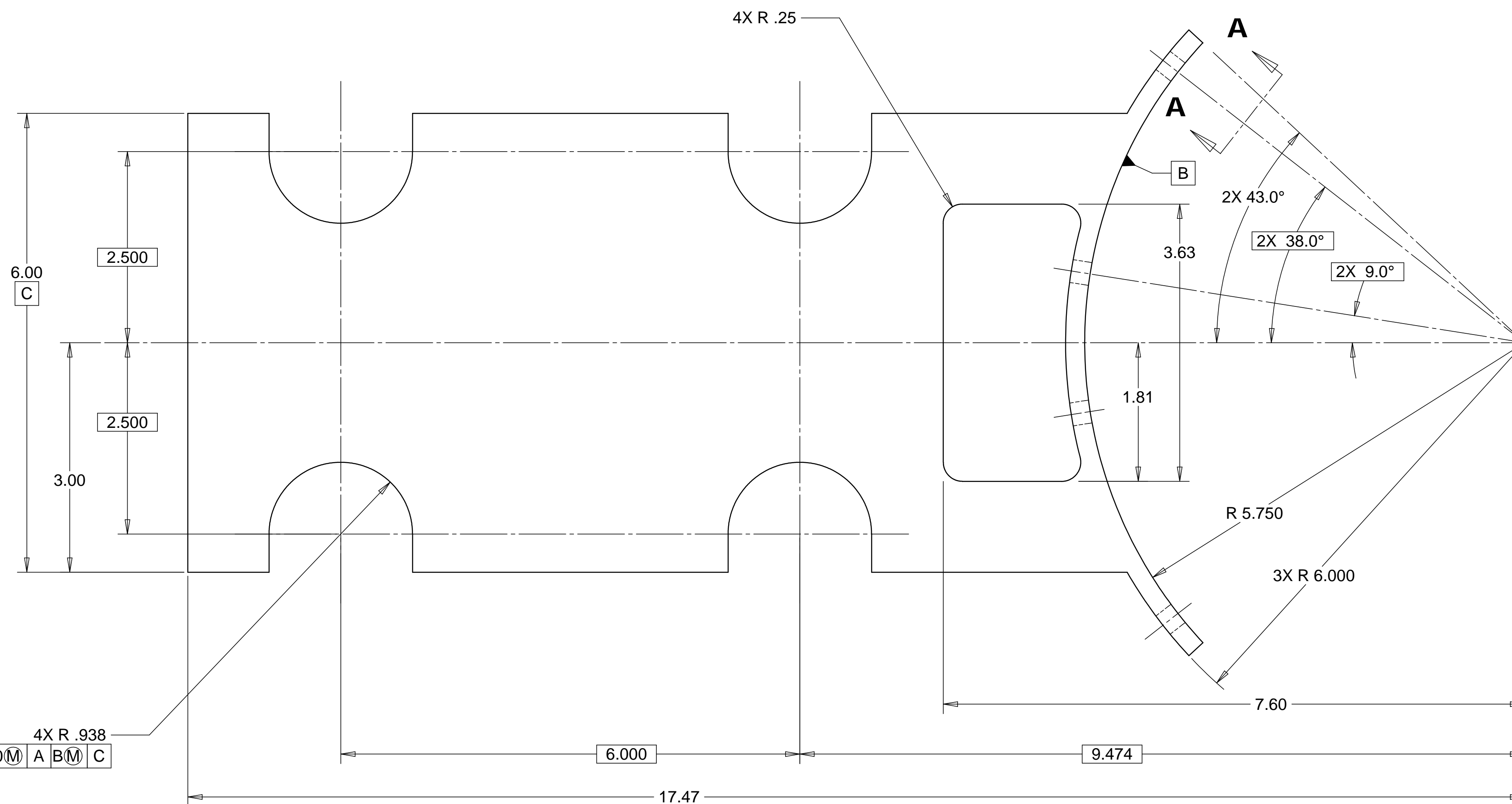

MATERIAL: ALUM 6061

4X R .938	⊕ .020(M)	A	B(M)	C
-----------	-----------	---	------	---

∥ .010	A
--------	---

∥ .010	A
--------	---

NOTES: UNLESS OTHER WISE SPECIFIED

1. ALL DIMENSIONS IN INCHES.
2. DIMENSIONS AND TOLERANCING PER ANASI Y14.5M-1994
3. SURFACE TEXTURE PER ANI/ASME B 46.1-1985
4. REMOVE ALL BURRS AND BREAK SHARP EDGES TO A MAXIMUM OF .015
5. ALL INSIDE CORNERS TO BE .015 RADIUS MAX
6. COUNTERSINK 82 DEGREES ALL TAPPED HOLES TO MAJOR DIAMETER
7. COUNTERSINK 82 DEGREES APPROXIMATELY .03/.06 DEEP ALL DRILLED HOLES
8. PARTS TO BE THOROUGHLY CLEANED TO REMOVE ALL OIL, GREASE, DIRT AND CHIPS
9. PART NUMBER (DRAWING NO., DASH NO., REVISION NO., SERIAL NO.) TO BE CLEARLY MARKED ON THE PART ITSELF.

ITEM NO.	QTY.	PART NO.	DESCRIPTION
PARTS LIST			
UNLESS OTHERWISE SPECIFIED: DIMENSIONS ARE IN INCHES -TOLERANCES-		CAD GENERATED DRAWING, DO NOT MANUALLY UPDATE DO NOT SCALE DRAWING	
DECIMALS .X = +/- .1 .XX = +/- .03 .XXX = +/- .010		ANGULAR = +/- .30' SURFACE FINISH = 250	
FINISH		SIGNATURE	DATE
PART NO. D972160-1		DESIGNED Roger L. Smith	04-02-99
		DRAWN Roger L. Smith	04-02-99
		CHECKED Erik Swensen	04-22-99
		ENGR. Erik Swensen	04-22-99
		APPROVED T. THOMPSON	04-22-99
TITLE HYTEC, INC LIGO Z PIVOT STATIONARY PLATE			DWG. NO. D972160
SCALE 1/1			SIZE SHEET NO. D 1 of 1
REVISION A			

8

7

6

5

4

3

2

1