

8

7

6

5

4

3

2

1

REVISIONS		DATE	APPROVED
REV	DESCRIPTION		
A	SEE ECN #D972157-A FOR CHANGE LISTING	05/11/99	T. THOMPSON

D

D

C

C

B

B

A

A

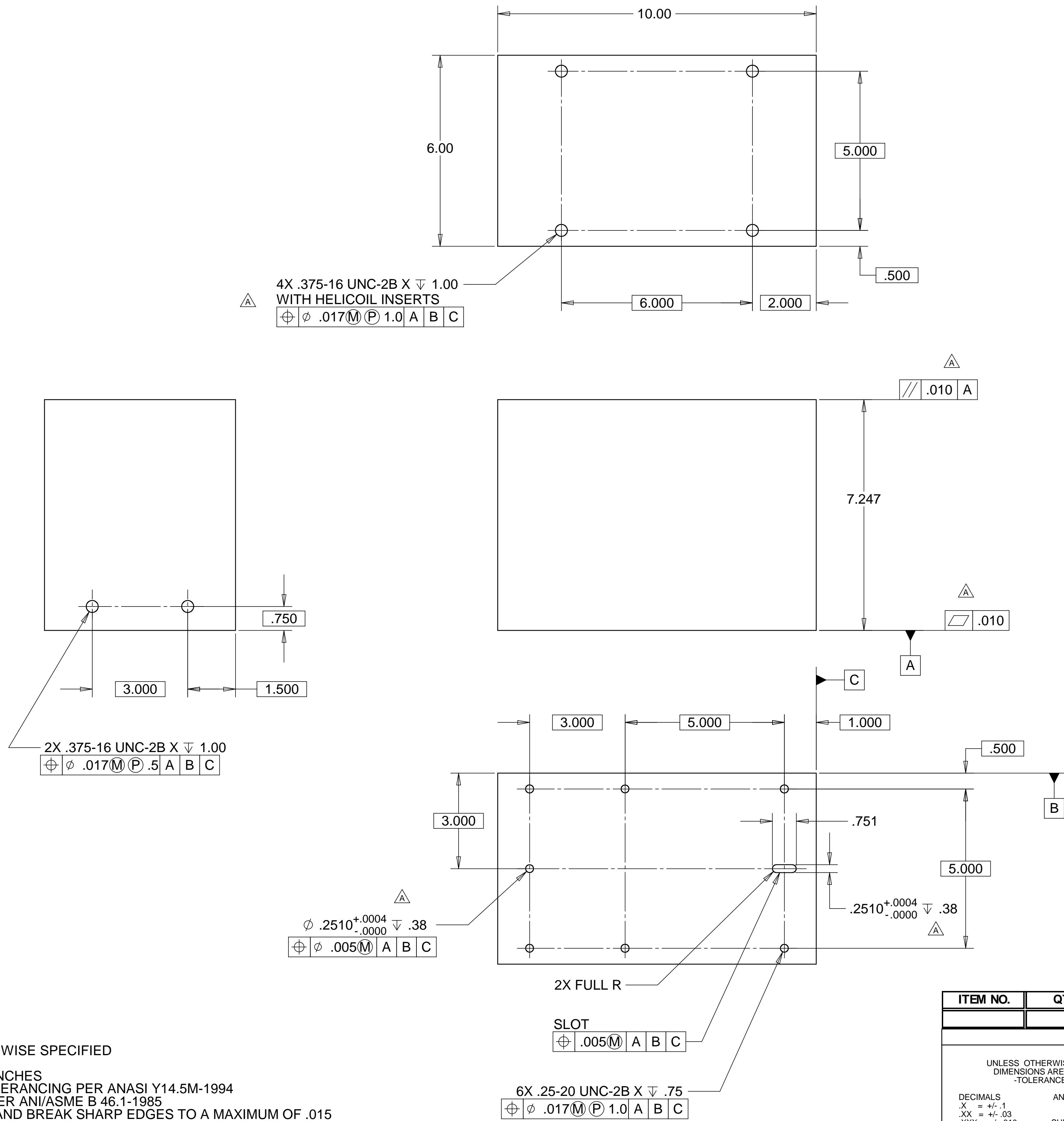

4X .375-16 UNC-2B X 1.00
WITH HELICOIL INSERTS
⊕ φ .017(M) (P) 1.0 A B C

2X .375-16 UNC-2B X 1.00
⊕ φ .017(M) (P) .5 A B C

φ .2510^{+0.0004}/_{-.0000} ∇ .38
⊕ φ .005(M) A B C

SLOT
⊕ φ .005(M) A B C

6X .25-20 UNC-2B X ∇ .75
⊕ φ .017(M) (P) 1.0 A B C

MATERIAL: ALUM. 6061

NOTES: UNLESS OTHER WISE SPECIFIED

1. ALL DIMENSIONS IN INCHES
2. DIMENSIONS AND TOLERANCING PER ANASI Y14.5M-1994
3. SURFACE TEXTURE PER ANI/ASME B 46.1-1985
4. REMOVE ALL BURRS AND BREAK SHARP EDGES TO A MAXIMUM OF .015
5. ALL INSIDE CORNERS TO BE .015 RADIUS MAX
6. COUNTERSINK 82 DEGREES ALL TAPPED HOLES TO MAJOR DIAMETER
7. COUNTERSINK 82 DEGREES APPROXIMATELY .03/.06 DEEP ALL DRILLED HOLES
8. PARTS TO BE THOROUGHLY CLEANED TO REMOVE ALL OIL, GREASE, DIRT AND CHIPS
9. PART NUMBER (DRAWING NO., DASH NO., REVISION NO., SERIAL NO.) TO BE CLEARLY MARKED ON THE PART ITSELF.

ITEM NO.	QTY.	PART NO.	DESCRIPTION
PARTS LIST			
UNLESS OTHERWISE SPECIFIED: DIMENSIONS ARE IN INCHES -TOLERANCES-			CAD GENERATED DRAWING, DO NOT MANUALLY UPDATE DO NOT SCALE DRAWING
DECIMALS ANGULAR = +/- .30'			
.X = +/- .1			HYTEC, INC TITLE LIGO LARGE SPACER BLOCK
.XX = +/- .03			
.XXX = +/- .010			
SURFACE FINISH = 250			
FINISH		SIGNATURE	DATE
		Roger L. Smith	04-02-99
DRAWN		Roger L. Smith	04-02-99
CHECKED		Erik Swensen	04-22-99
ENGR.		Erik Swensen	04-22-99
APPROVED		T. THOMPSON	04-22-99
PART NO. D972157-1		DWG. NO. D972157	SIZE SHEET NO. D 1 of 1
		SCALE 1/2	REVISION A

8

7

6

5

4

3

2

1