

8 7 6 5 4 3 2 1

REVISIONS			
REV.	DESCRIPTION	DATE	APPROVED

D  
C  
B  
A

D  
C  
B  
A

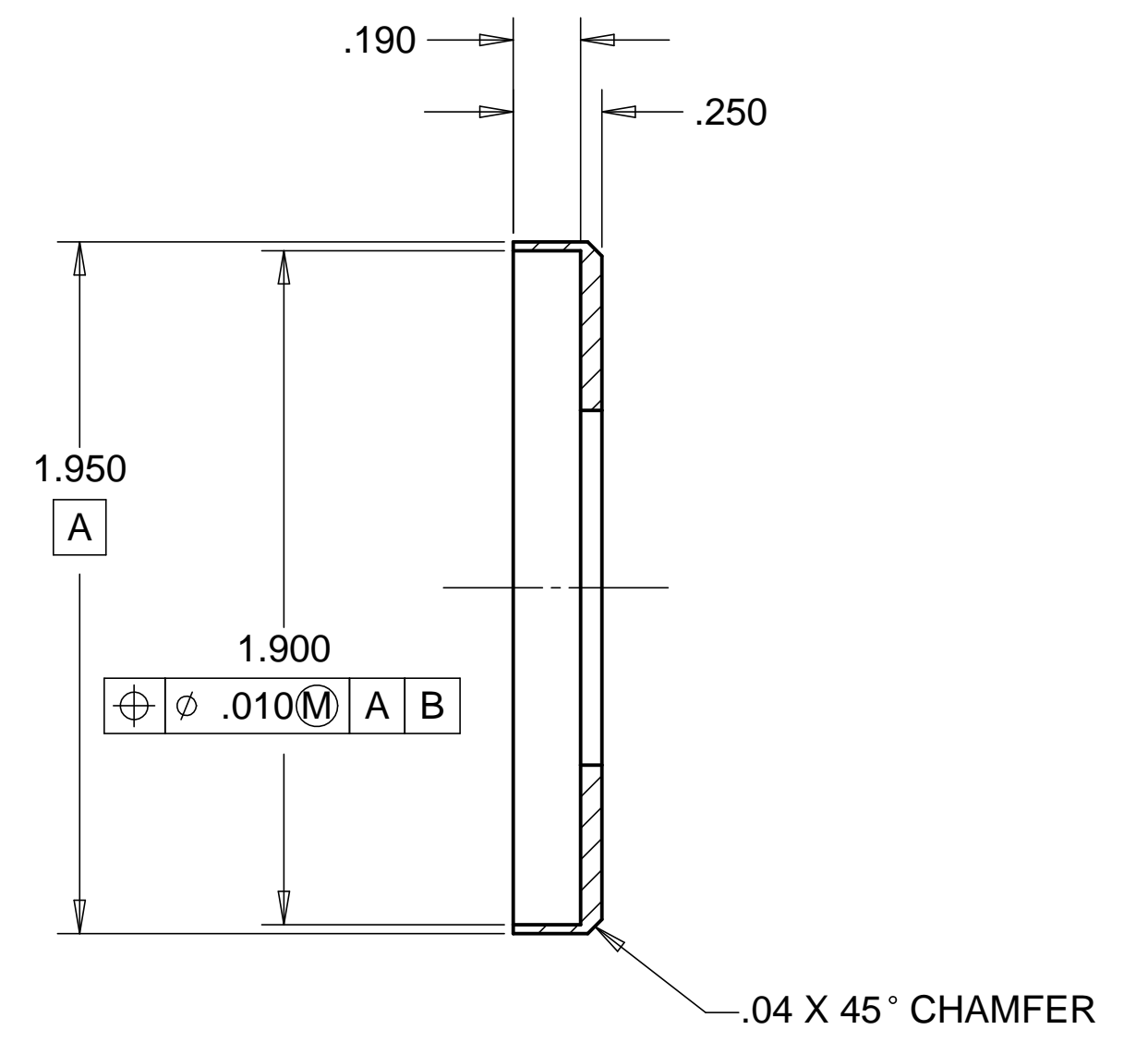
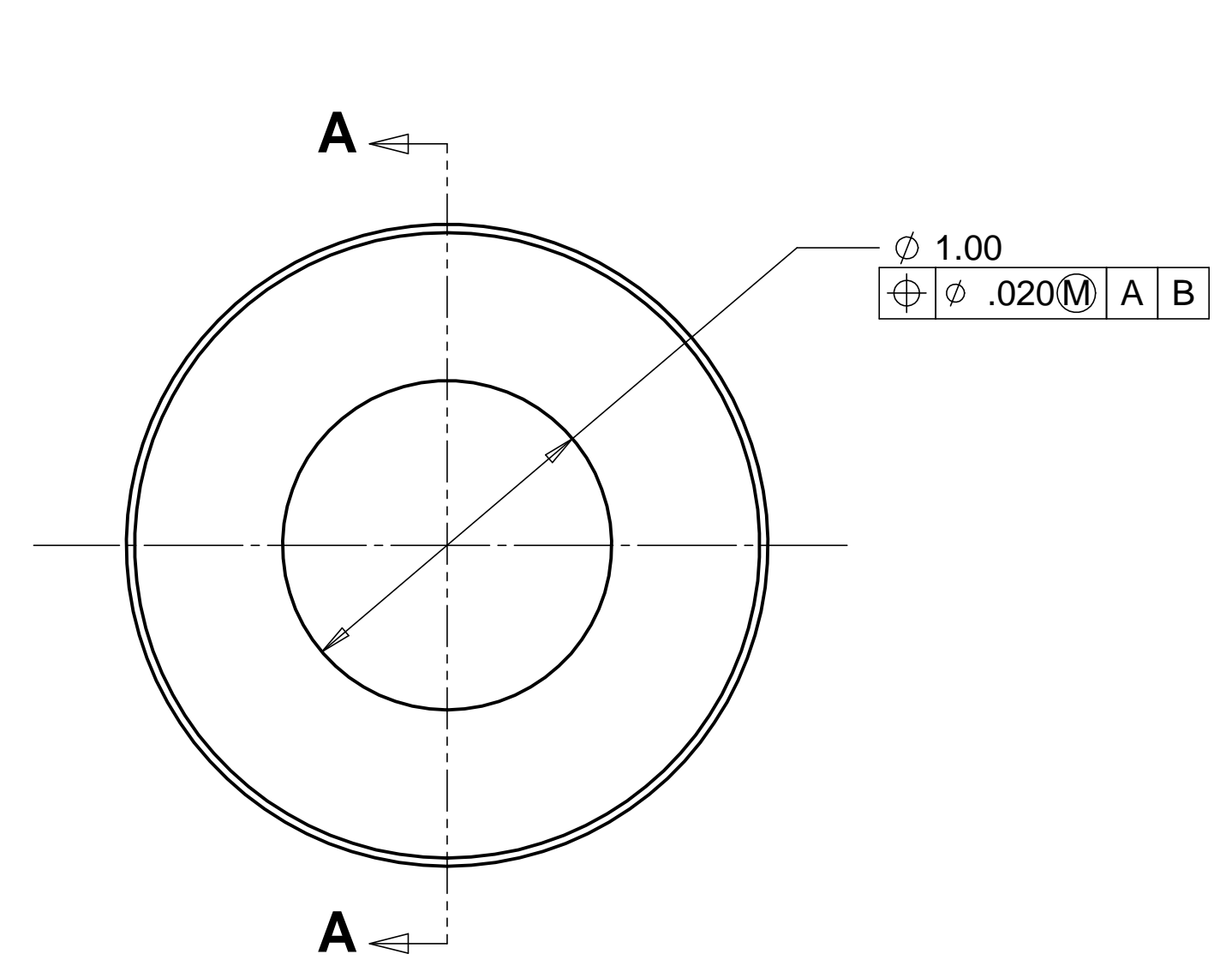

SECTION A-A

MATL: RULON  
WEIGHT: lbs.

NOTES: UNLESS OTHER WISE SPECIFIED

1. ALL DIMENSIONS IN INCHES
2. DIMENSIONS AND TOLERANCING PER ANASI Y14.5M-1994
3. SURFACE TEXTURE PER ANI/ASME B 46.1-1985
4. REMOVE ALL BURRS AND BREAK SHARP EDGES TO A MAXIMUM OF .015
5. ALL INSIDE CORNERS TO BE .015 RADIUS MAX
6. COUNTERSINK 82 DEGREES ALL TAPPED HOLES TO MAJOR DIAMETER
7. COUNTERSINK 82 DEGREES APPROXIMATELY .015 DEEP ALL DRILLED HOLES
8. PARTS TO BE THOROUGHLY CLEANED TO REMOVE ALL OIL, GREASE, DIRT AND CHIPS
9. PART NUMBER (DRAWING NO. PLUS DASH NO. PLUS SERIAL NO.) TO BE CLEARLY MARKED ON THE PART.

PARTS LIST			
UNLESS OTHERWISE SPECIFIED: DIMENSIONS ARE IN INCHES -TOLERANCES-  DECIMALS            ANGULAR = +/- 30' .X = +/- .1 .XX = +/- .03 .XXX = +/- .010            SURFACE FINISH = 250	CAD GENERATED DRAWING, DO NOT MANUALLY UPDATE DO NOT SCALE DRAWING		<b><i>HYTEC, INC</i></b>
	FINISH		TITLE <b>LIGO SCISSOR TABLE SPRING SHIM</b>
PART NO. <b>D972143-1</b>	DESIGNED ROGER L. SMITH	SIGNATURE ROGER L. SMITH	DATE 01-26-98
	CHECKED E. SWENSEN	ENGR. E. SWENSEN	DATE 03-26-98
APPROVED E. SWENSEN		DATE 03-26-98	DWG. NO.            SIZE            SHEET NO. <b>D972143            D            1 of 1</b>
SCALE 2/1		REVISION	

8 7 6 5 4 3 2 1