

NOTES:

1. PAINT MEDIUM TEXTURED PHTHALO GREEN  
SHERWIN WILLIAMS # SW-F63TX-G72
2. MASK BOTTOM AND SIDE SURFACES SHOWN.  
APPLY ZINC PHOSPHATE COATING TO MASKED  
AREAS.

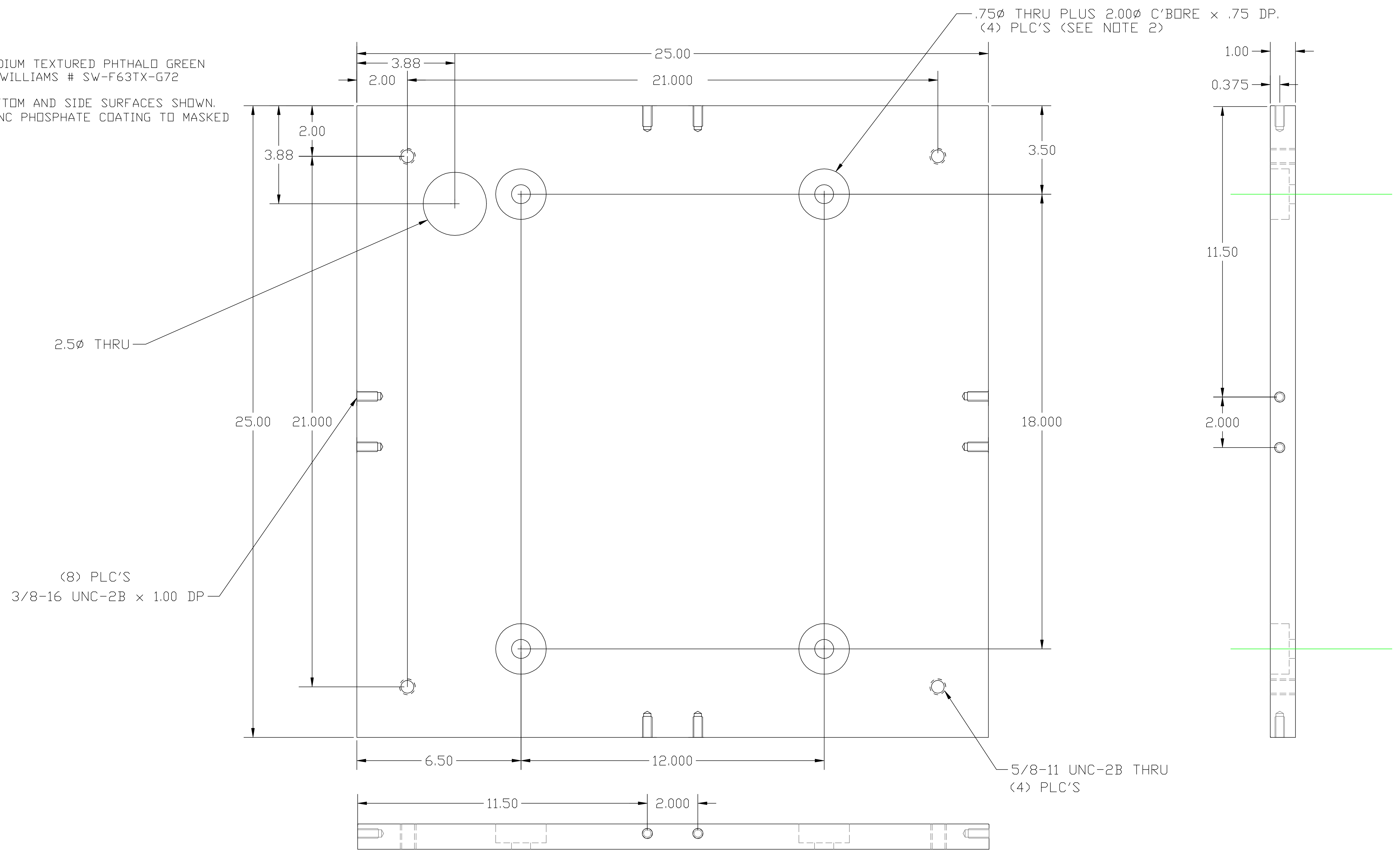

UNLESS OTHERWISE SPECIFIED DIMENSIONS ARE IN INCHES		TOLERANCES: FRACTIONAL ± 1/16(.16) ANGULAR ± 1° TWO PLACE DECIMAL ± .01(.025) THREE PLACE DECIMAL ± .005(.013)		FINISHED SURFACE RMS 63 BREAK CORNERS IN: OUT: .02 REMOVE ALL BURRS		MATERIAL: ASTM A36 STL		HEAT TREAT: -		FINISH: SEE NOTE 1.		REV		DESCRIPTION		DCC		SYS		DET		CDS		VE		CC		BT		CHECK		DRWN		DATE	
DWG. NO.		DESCRIPTION		USED QN: D970190-00		NEXT ASS'Y: -		B		A		00		REV		DCC		SYS		DET		CDS		VE		CC		BT		CHECK		DRWN		DATE	
REFERENCE DRAWINGS																																			

**LIGO**  
CALIFORNIA INSTITUTE OF TECHNOLOGY  
MASSACHUSETTS INSTITUTE OF TECHNOLOGY

GROUT PLATE  
SUPPORT STRUCTURE  
OPTICAL LEVER

CAD FILE: D970202-B  
SCALE: 1:2

SIZE: D  
DWG. NO.: D970202-B-D  
SHEET: 1 of 1