

1

2

3

4

REV	DATE	DRAWN BY	CHECKED	DCC	DCN/DESCRIPTION
A	2/13/98	J. Hozel			E980016/INITIAL RELEASE

NOTES: (UNLESS OTHERWISE SPECIFIED)  
 1. BREAK ALL SHARP EDGES AND BURRS.  
 2. THIS FIXTURE MAY BE ASSEMBLED FROM MULTIPLE PIECES THAT HAVE BEEN GLUED TOGETHER.

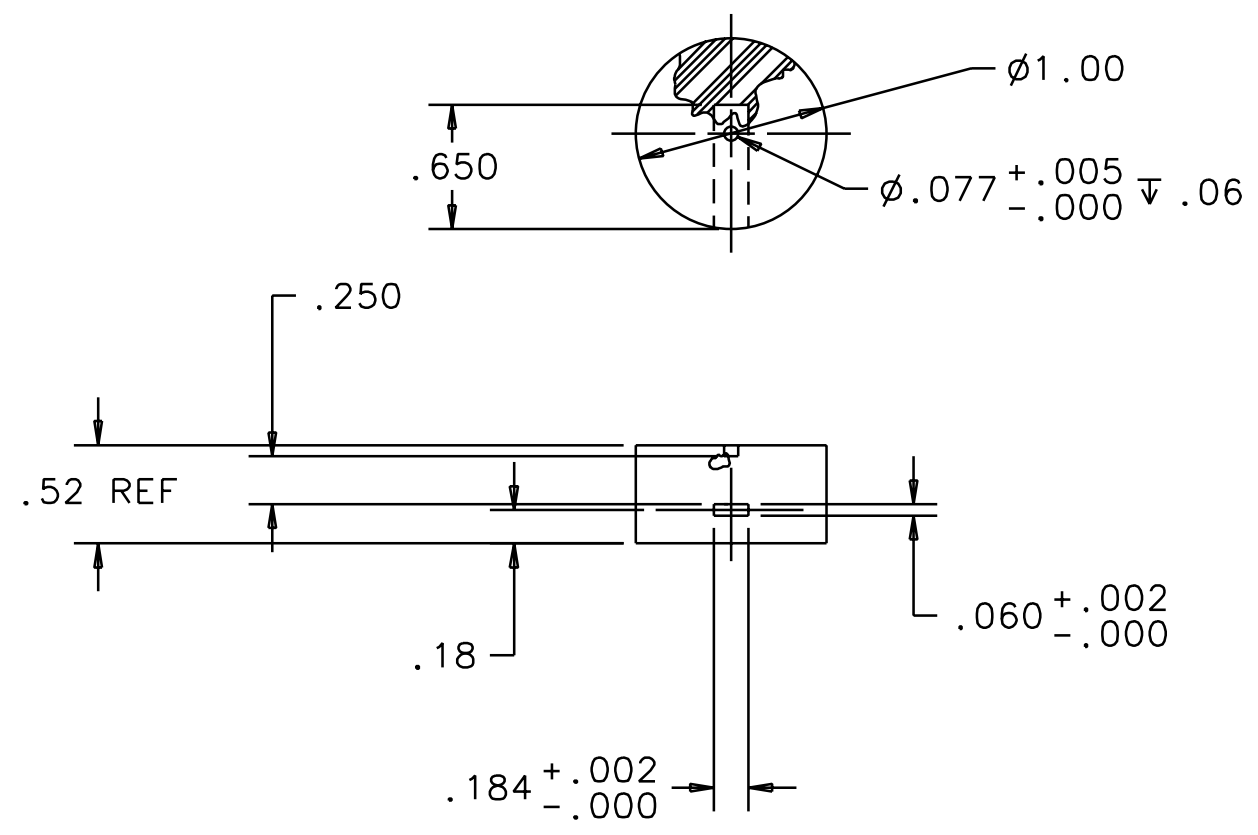

QTY REQD	FSCM NO	PART OR IDENTIFYING NO	NOMENCLATURE OR DESCRIPTION	MATERIAL SPECIFICATION	ITEM NO
PARTS LIST					
UNLESS OTHERWISE SPECIFIED DIMENSIONS ARE IN IN (mm) TOLERANCES ARE: FRACTIONS DECIMALS .XX = ±.01 .XXX = ±.005 ANGLE = ±.5° DO NOT SCALE DRAWING			APPROVALS DRAWN J. Hozel CHECKED	DATE 5/6/97	LIGO CALIFORNIA INSTITUTE OF TECHNOLOGY MASSACHUSETTS INSTITUTE OF TECHNOLOGY TITLE MAGNET STRENGTH FIXTURE
MATERIAL INSULATING CLEAR PLASTIC FINISH NONE					
SCALE 1/1			FILENAME /home/dcc/docs/D970169.pdf		DWG NO. D970169
					REV A
					SHEET 1 OF 1

1

2

3