

PC. 5 MAKE FROM $\frac{3}{8}$ " THK. 6061-T6 ALUM. (4 PCS. REQ'D.)

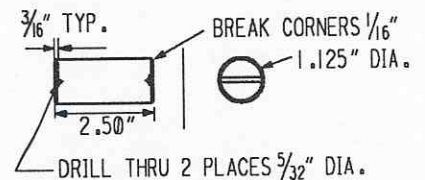

PC. 6 MAKE FROM 1-1/8" DIA. STAINLESS STEEL ROUND BAR STOCK (2 PCS. REQ'D.)

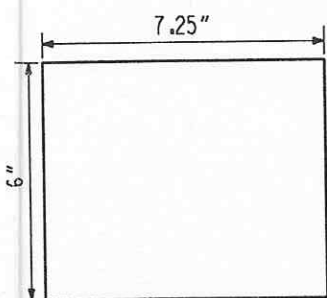

PC. 3 MAKE FROM $\frac{3}{8}$ " THK. 6061-T6 ALUM. (4 PCS. REQ'D.)

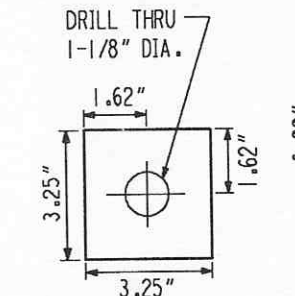

PC. 4 MAKE FROM $\frac{3}{8}$ " THK. 6061-T6 ALUM. (4 PCS. REQ'D.)

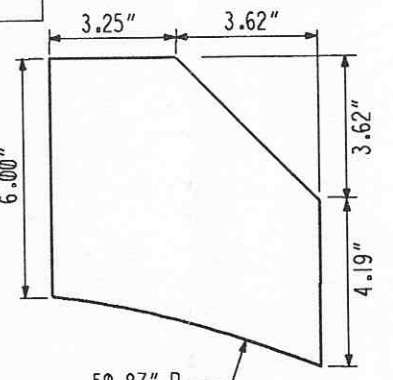

PC. 2 MAKE FROM $\frac{3}{8}$ " THK. 6061-T6 ALUM. (16 PCS. REQ'D.)

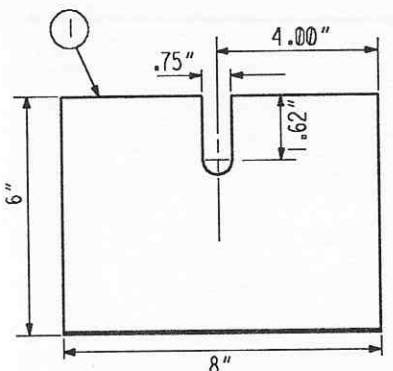

PC. 1 MAKE FROM $\frac{1}{2}$ " THK. 6061-T6 ALUM. (4 PCS. REQ'D.)

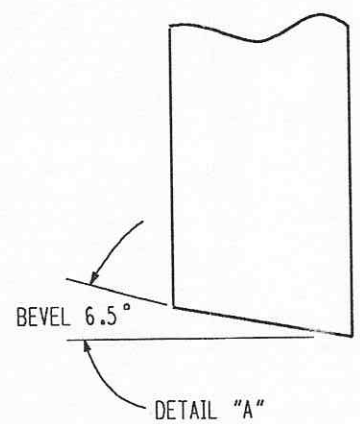
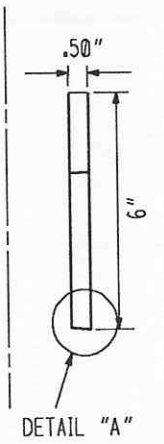

ALSO PROVIDE EIGHT $\frac{1}{8}$ " DIA. X 2" LONG SS COTTER PINS McMASTER-CARR #98401A480, TWO $\frac{3}{8}$ " SS WASHERS McMASTER-CARR #91860A035, TWO $\frac{3}{8}$ " UNC SS COUPLING NUTS McMASTER-CARR #90268A035, TWO $\frac{3}{8}$ " X 8" GALVANIZED EYEBOLTS McMASTER-CARR #3016T54, FOUR 1-1/8" STAINLESS STEEL FLAT WASHERS McMASTER-CARR #92141A039

INDICATES CHANGE FROM PREVIOUS ISSUE

REMOVED BOTTOM NOTES IN TITLE BLOCK		Supplier's/Purchaser's No.	
CBI			
LIGO-BEAM TUBE			
HANFORD, WA & LIVINGSTON, LA			
CIRCUMFERENTIAL LEAK TEST BOX			
HINGE DETAILS			
Customer's No.		Contract No.	
By CLD Chkd DWJ Date 2-26-96		953571	
M. L. TELLALIAN		Dwg. ER602 Rev. 1	
Engineering Supervisor		Sheet	
LIGO-D970055-01-B			