

ITEM	PART NUMBER	SUFFIX	QTY	LN	DESCRIPTION
1	V0494060		1	EA	FLANGE, GROOVED, 44 1/4" ID X 52" O.D.
2	V0494047		1	EA	FLANGE, FLAT FACE, 44 1/4" ID X 80" OD
3					
4	NRN		3	EA	TIE-ROD ASSY. (PER V049-4-124)
5					
6	V0494A1P1		1	EA	BELLOWS ASSY. (PER V049-2-017)
7	V049M321		3	6 EA	HALF NIPPLE, SST 304L, CONFLAT, 10" OD X 8" OD TUBE
8					
9					
10	202667		3	6 EA	FLANGE, CONFLAT, BLANK 10" OD
11					
12					
13	202678		3	24 EA	BOLT, SAI93 B7, HEX, 7/8-9 UNC X 4" LG.
14	202679		3	24 EA	NUT, SAI94 ZH, HEX, 7/8-9 UNC
15	202581		3	48 EA	WASHER, STL, 1 3/4" OD X 15/16" ID X 1/4" THK
16	V049M026		1	EA	O-RING, VITON (PER SPEC. V049-2-045)
17	V049M027		1	EA	O-RING, VITON (PER SPEC. V049-2-045)
18	202671		3	6 EA	GASKET, COP OFHC COFC, CONFLAT, 10" OD
19	V049M777		144	EA	BOLT, 18-8 SST, HEX HD, 5/16-18x2 1/2" LG.
20	V049M782		144	EA	NUT, SILICON BRZ, HEX 5/16-18
21	V049M785		288	EA	WASHER, 18-8 SST, FLAT 5/16
22	V049M061		1	EA	3/4" O.D. ELBOW X 2 3/4" O.D.CF.

NR ELECTROLESS NICKEL PLATED
NRN SUPPLIED BY BELLOWS VENDOR

ALL CONFLATS TO SHOW BOLT HOLES STRADDLING VERTICAL C. SEE NOTE 15

NOTES:

- CONFLAT LEAK CHECK SLOTS ARE TO BE POSITIONED ON VERTICAL CENTERLINE.
- CONFLAT FLANGES ARE TO HAVE PROTECTIVE COVERS AT ALL TIMES DURING & AFTER MANUFACTURING.
- PLATES PRIOR TO ROLLING MUST HAVE DIAGONAL CORNER TO CORNER DIMENSIONS WITHIN 1/16" OF EACH OTHER.
- EACH FINISHED SHELL IS TO BE MARKED WITH A SEQUENTIAL PSI SERIAL NUMBER. THE NUMBER IS TO BE MADE FROM THE DRAWING PLUS THE SEQUENTIAL NUMBER. V0494A1-01, 02 ETC.
- TIGHTEN TIE-ROD NUTS WITH BELLOWS IN 'FREE' POSITION TO 100 FT-LB PRIOR TO LEAK TEST
- LEAK TEST & METHOD PER PSI SPEC. V049-2-014
- CERTIFIED MANUFACTURER'S MATERIAL TEST REPORTS REQUIRED, AS NOTED.
- BOLT HOLES OF ALL FLANGES TO STRADDLE VERTICAL CENTERLINE ±0.015.
- CLEAN PER SPEC. V049-2-015
- DO NOT USE CARBON STEEL BRUSHES OR BRUSHES CONTAMINATED WITH CARBON STEEL ON STAINLESS OR ALUMINUM MATERIAL.
- SPOOL FABRICATION TO BE IN ACCORDANCE WITH SPEC. V049-2-097
- FOR FLANGE DETAILS SEE DWG. V049-4-047 & 060.
- THIS FLANGE INCLUDES AN ANNULAR CHANNEL BETWEEN O-RINGS FOR A SINGLE PUMPOUT PORT, SEE DWG V049-4-061.
- WDS NO'S. REFER TO WELD DATA SPEC. V049-2-084.

APPROX. WEIGHT: 1849#

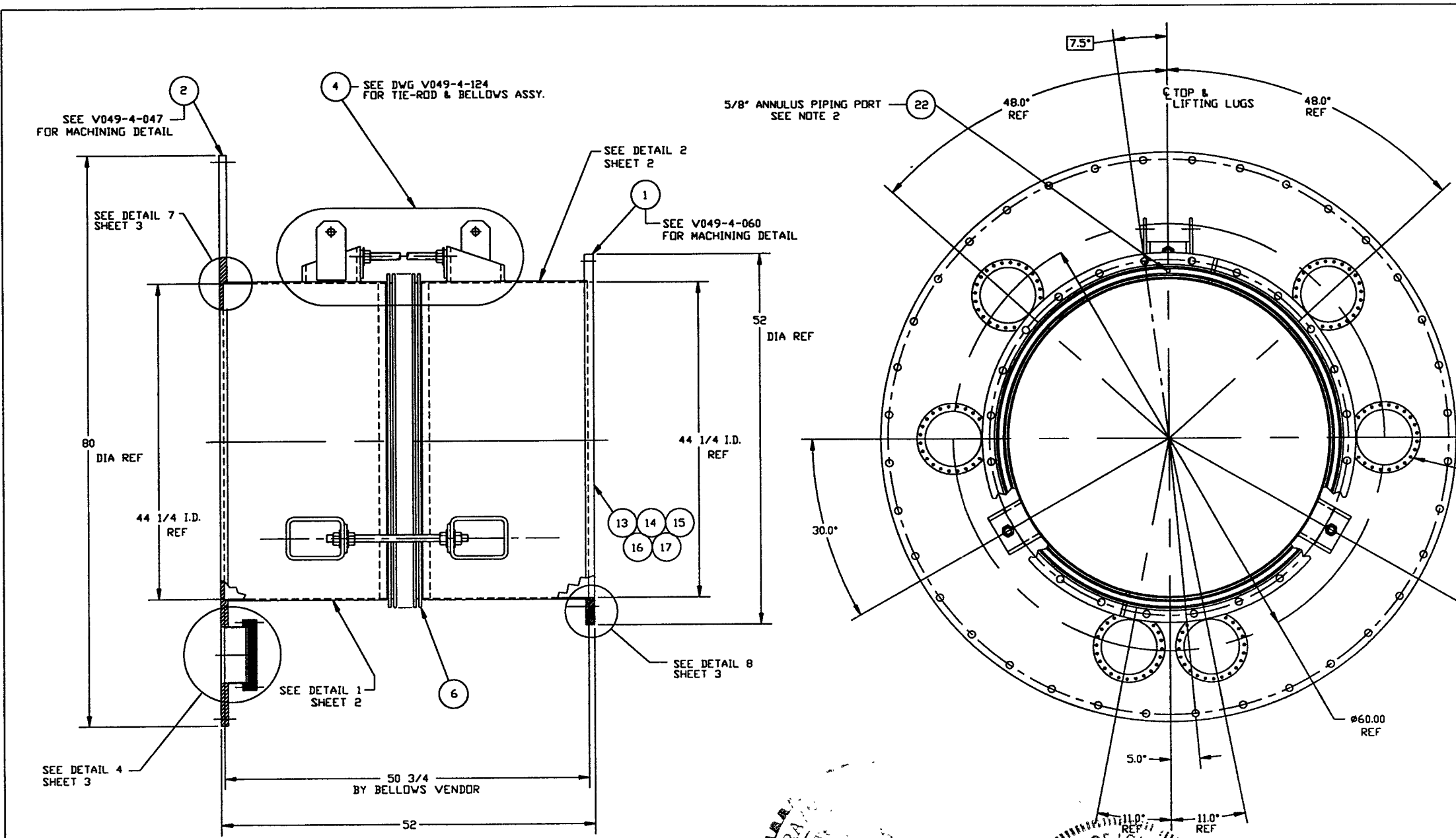
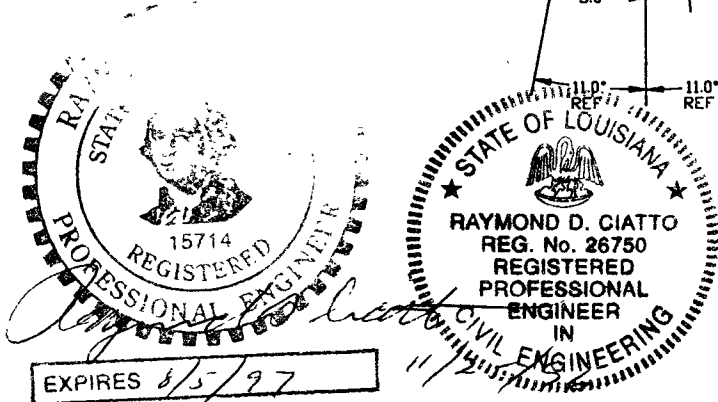

PROPRIETARY AND CONFIDENTIAL
THIS DOCUMENT CONTAINS PROPRIETARY INFORMATION BELONGING TO PROCESS SYSTEMS INTERNATIONAL, INC. OR ITS AFFILIATED COMPANIES AND SHALL BE USED ONLY FOR THE PURPOSE FOR WHICH IT WAS SUPPLIED. IT SHALL NOT BE COPIED, REPRODUCED OR OTHERWISE USED, NOR SHALL SUCH INFORMATION BE FURNISHED IN WHOLE OR IN PART TO OTHERS EXCEPT IN ACCORDANCE WITH THE TERMS OF ANY AGREEMENT UNDER WHICH IT WAS SUPPLIED OR WITH THE PRIOR WRITTEN CONSENT OF PROCESS SYSTEMS INTERNATIONAL, INC. AND SHALL BE RETURNED UPON REQUEST.

SYMBOL	CHARACTERISTIC	UNLESS OTHERWISE SPECIFIED DIMENSIONS ARE IN INCHES
□	FLATNESS	FRACTIONAL ± .3
○	CYLINDRICITY	ANGULAR ± .001
∥	PARALLELISM	TWO PLACE DECIMAL ± .005
⊥	PERPENDICULARITY	FINISHED SURFACE TO BE BREAK CORNERS TO REMOVE ALL BURRS
∠	ANGULARITY	DO NOT SCALE THIS DRAWING
⊕	TRUE POSITION	USED ON:
⊙	CONCENTRICITY	NEXT ASSY.

REV	DESCRIPTION	CHKD	DRWN	DATE	DEDR
2	DESIGN UPDATE/ISSUED FOR FABRICATION			11/22/96	0180
1	DESIGN UPDATE / FABRICATION (BELLOWS ASSY. ONLY)			9/11/96	0191
0	ISSUED FOR FDR			4/27/96	0145
PI	PRELIMINARY			4/13/96	

REV	DESCRIPTION	CHKD	DRWN	DATE	DEDR
2	DESIGN UPDATE/ISSUED FOR FABRICATION			11/22/96	0180
1	DESIGN UPDATE / FABRICATION (BELLOWS ASSY. ONLY)			9/11/96	0191
0	ISSUED FOR FDR			4/27/96	0145
PI	PRELIMINARY			4/13/96	

PROCESS SYSTEMS INTERNATIONAL, INC.
20 WALCUP DR. WESTBOROUGH, MASSACHUSETTS 01581 USA

ADAPTER A-1
44 1/4" ID X 72 1/4" I.D.
LIGD VACUUM EQUIPMENT

CAD FILE: V049-4-A1
SCALE: 1-1/2" = 1"
SHEET: 1 OF 3

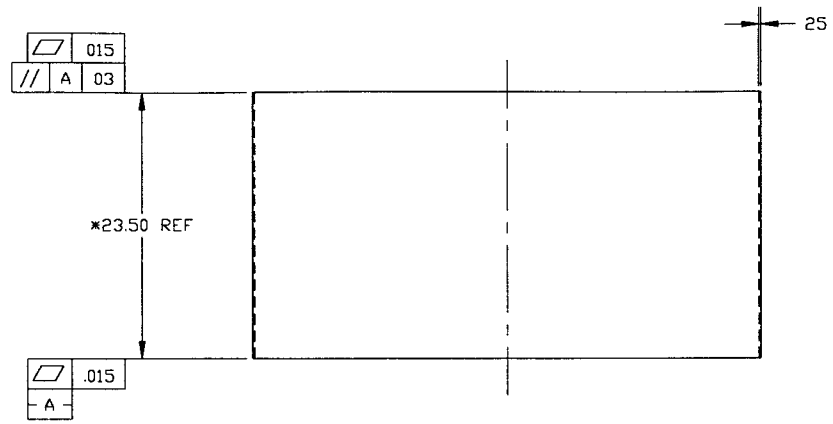

* NOTE
FINAL FINISHED LENGTH TO BE
DETERMINED BY BELLOWS VENDOR

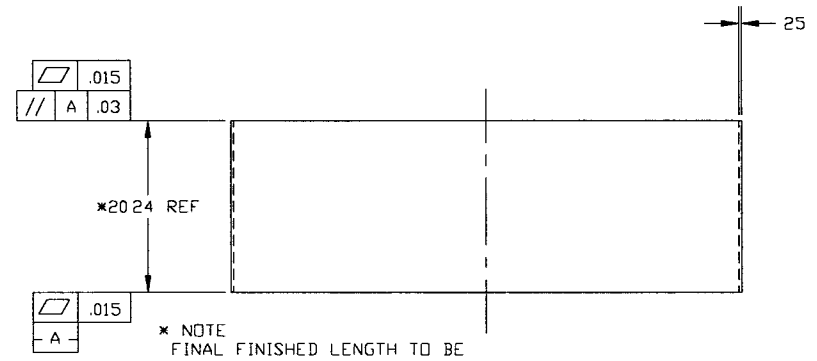

* NOTE
FINAL FINISHED LENGTH TO BE
DETERMINED BY BELLOWS VENDOR

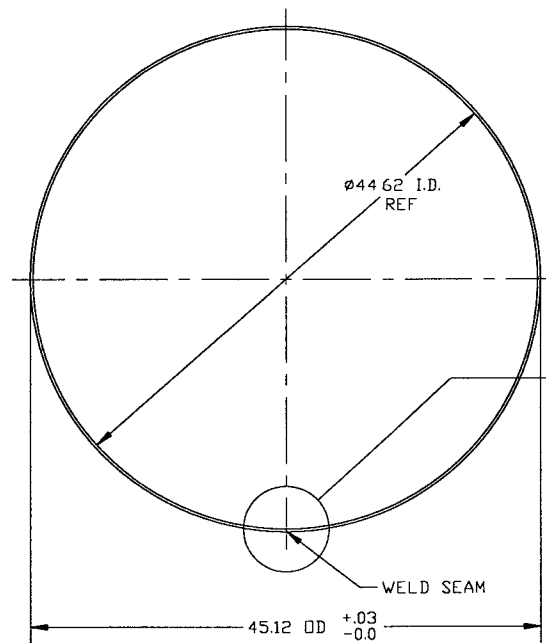

DETAIL 1
QTY: 1
MAKE FROM V049M159-1

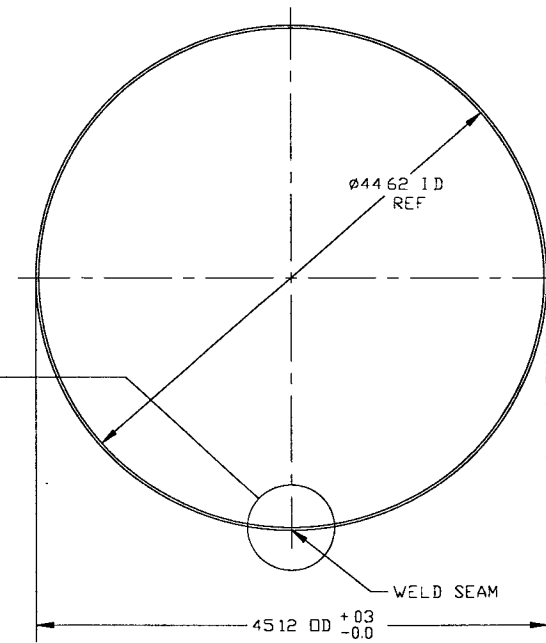
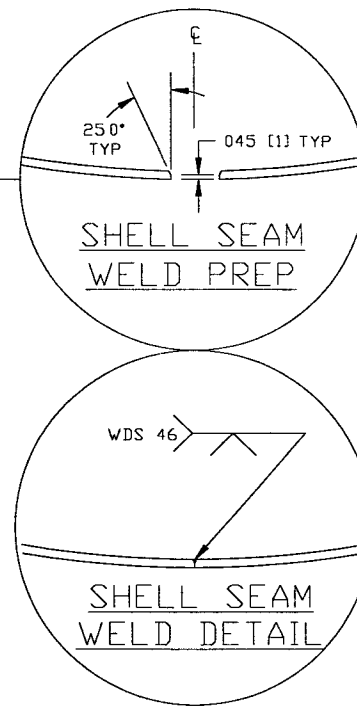

DETAIL 2
QTY: 1
MAKE FROM V049M159-1

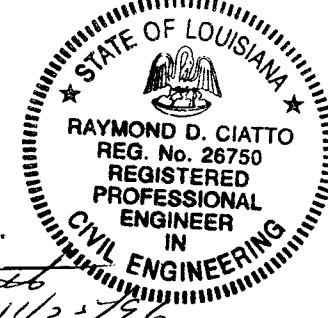

PROCESS SYSTEMS INTERNATIONAL INC. 20 WALKUP DR WESTBOROUGH, MASSACHUSETTS 01581 USA			
ADAPTER A-1 44 5/8" I.D. X 72 1/4" I.D. LIGD VACUUM EQUIPMENT			
CAD FILE 4A1S2	SIZE D	DWG NO. V049-4-A1	REV 2
SCALE AS NOTED	SHEET 2 OF 3		

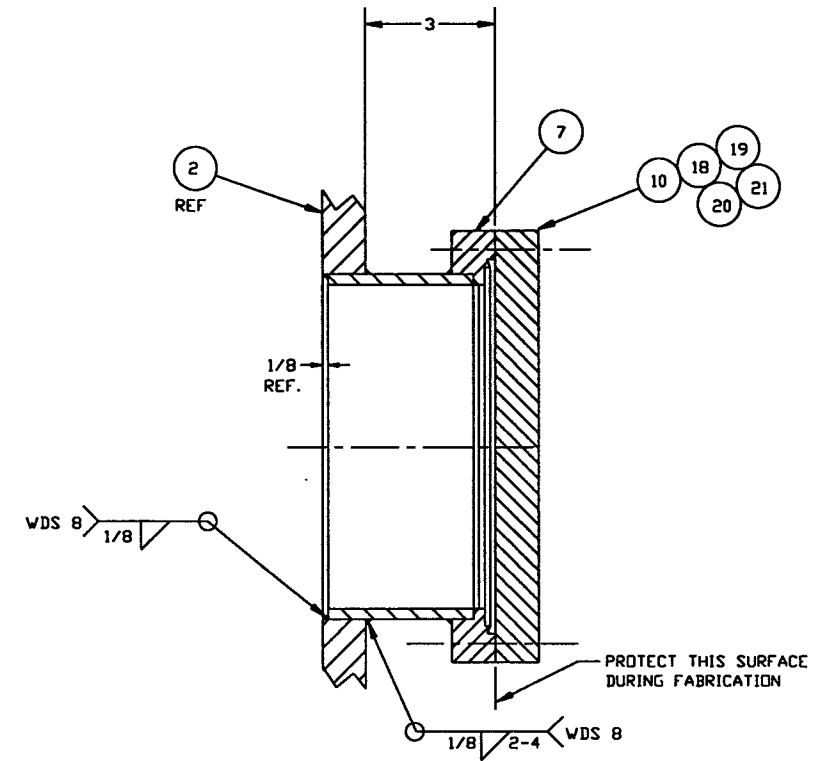
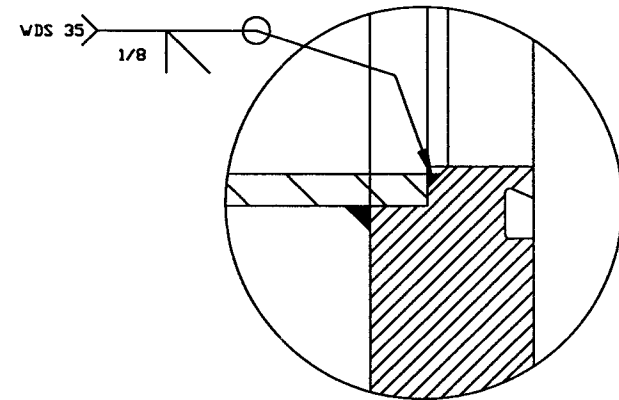

DETAIL 4
6 PLCS.

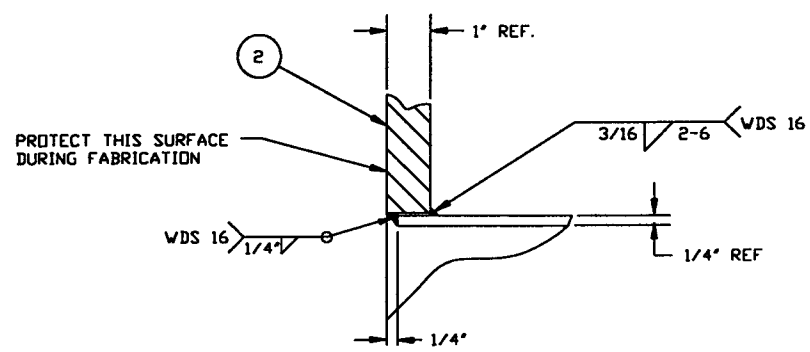

DETAIL "7"

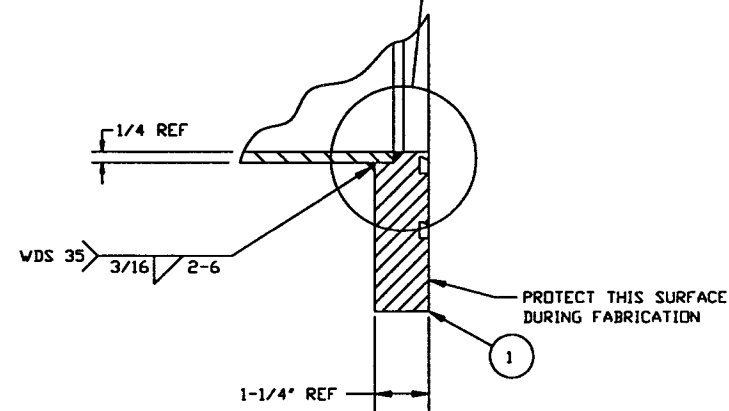

DETAIL "8"

STATE OF LOUISIANA
 RAYMOND D. CIATTO
 REG. No. 26750
 REGISTERED
 PROFESSIONAL
 ENGINEER
 IN
 CIVIL ENGINEERING
 11/21/96
 EXPIRES 8/5/97

 PROCESS SYSTEMS INTERNATIONAL INC. 20 WALKUP DR. WESTBOROUGH, MASSACHUSETTS 01581 USA			
ADAPTER A-1 44 5/8 I.D. X 72 1/4 I.D. LIGD VACUUM EQUIPMENT			
CAD FILE 4A1S3	SIZE D	DWG. NO. V049-4-A1	REV. 2
SCALE AS NOTED	SHEET 3 OF 3		