

This document and the design it covers are the property of PARSONS. They are loaned only with the borrower's expressed written agreement that they will not be reproduced, copied, loaned, exhibited, or used in any other way, except by written consent from PARSONS to the borrower.

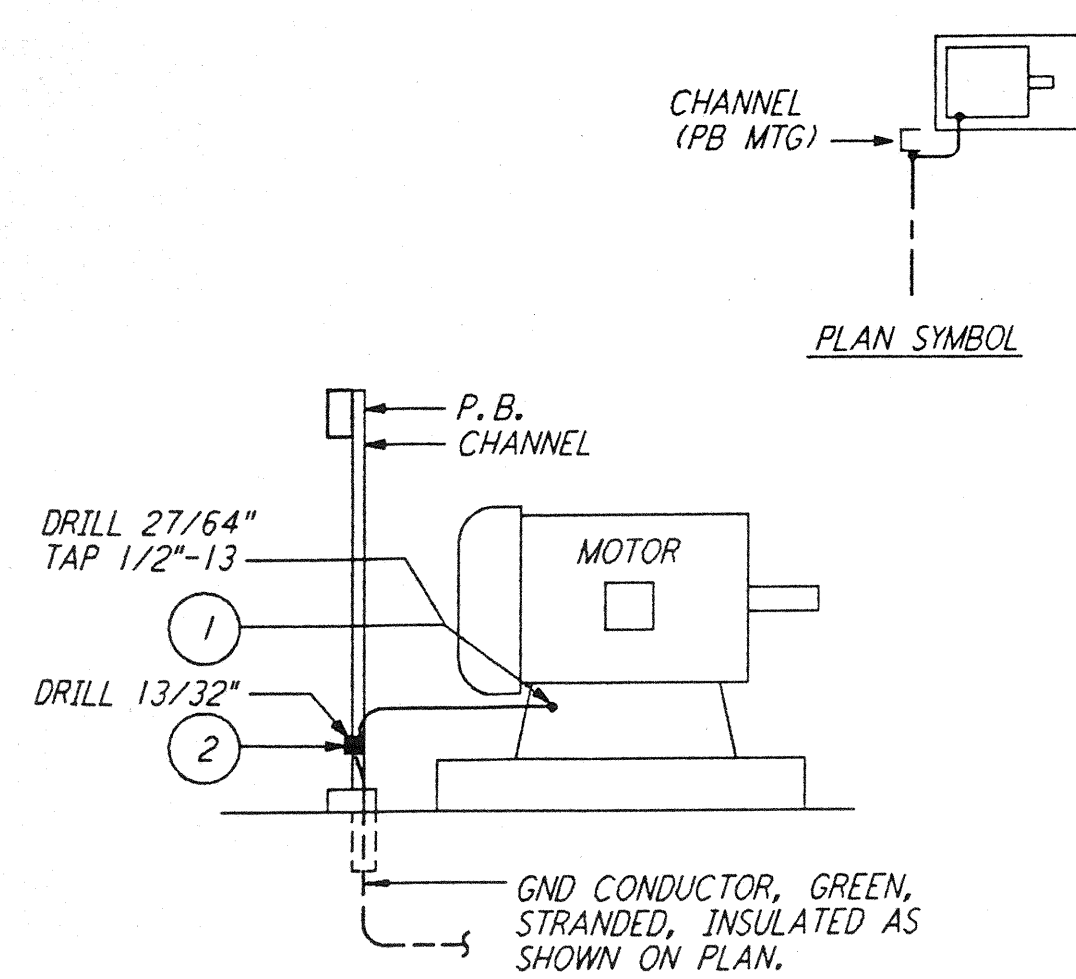

LIST OF MATERIAL

ITEM NO.	QTY	DESCRIPTION
1	1	SERVIT POST, #2-#2/0 WIRES, BURNDY K2C26
2	1	CONNECTOR, TWO #4-#2/0 WIRE FLAT BAR, BURNDY TYPE GCM26 (LONGER BOLT AS REQ'D)

MOTOR GROUNDING (1) REF
 N. T. S.

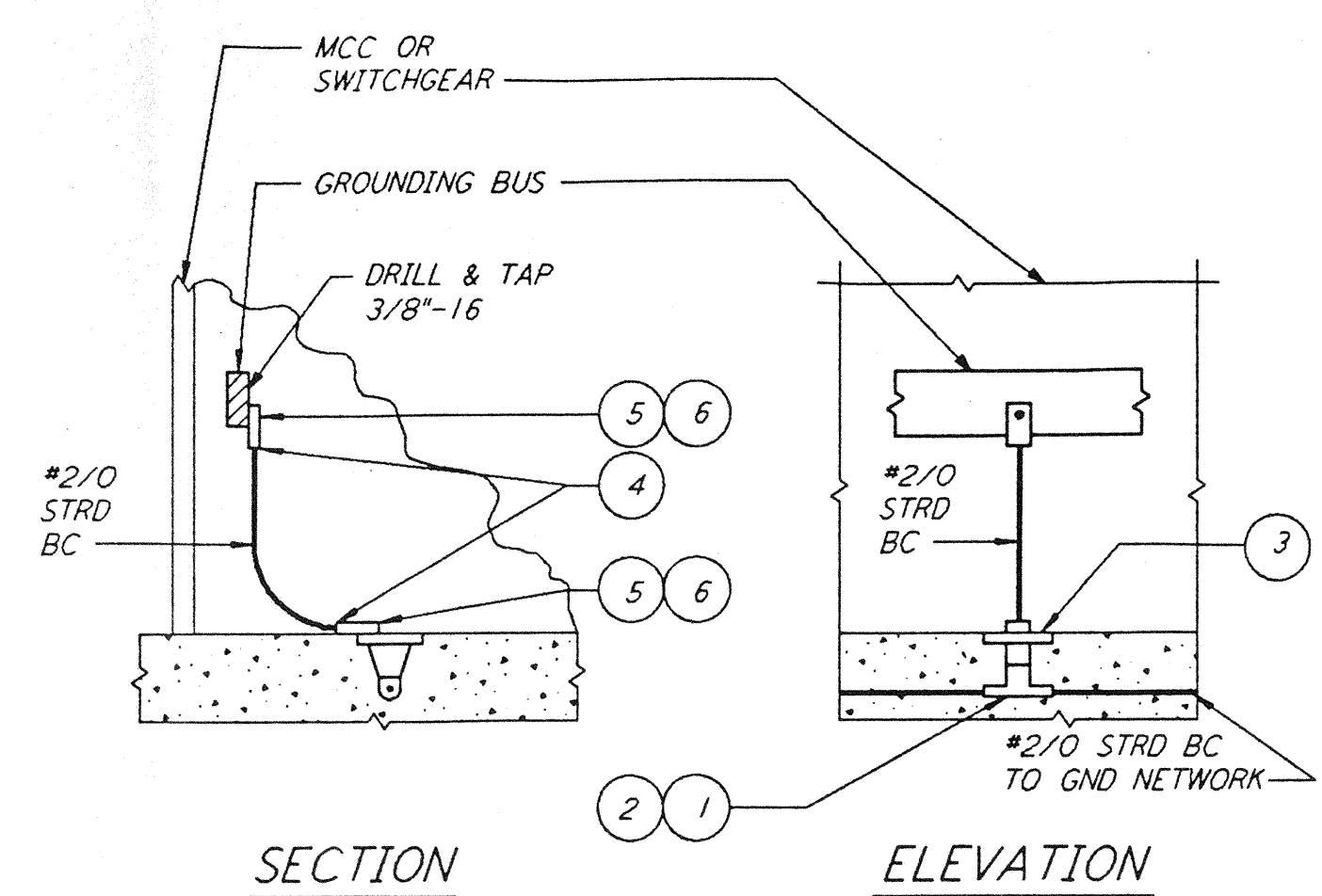

LIST OF MATERIAL

ITEM NO.	QTY	DESCRIPTION
1	AR	MOLD HORIZONTAL TEE, #4/0-#4/0 WIRE
2	1	CARTRIDGE, STANDARD POWDER 150 GRAMS
3	1	FLUSH PLATE, #4/0 WIRE SIZE, 3/8\"/>
4	2	LUG, #1/0-#2/0 WIRE x 3/8\"/>
5	2	SILICONE-BRONZE BOLT, 3/8\"/>
6	2	SILICONE-BRONZE LOCKWASHER SPRING 3/8\"/>

SWITCHGEAR OR MCC GROUNDING (2) REF
 N. T. S.

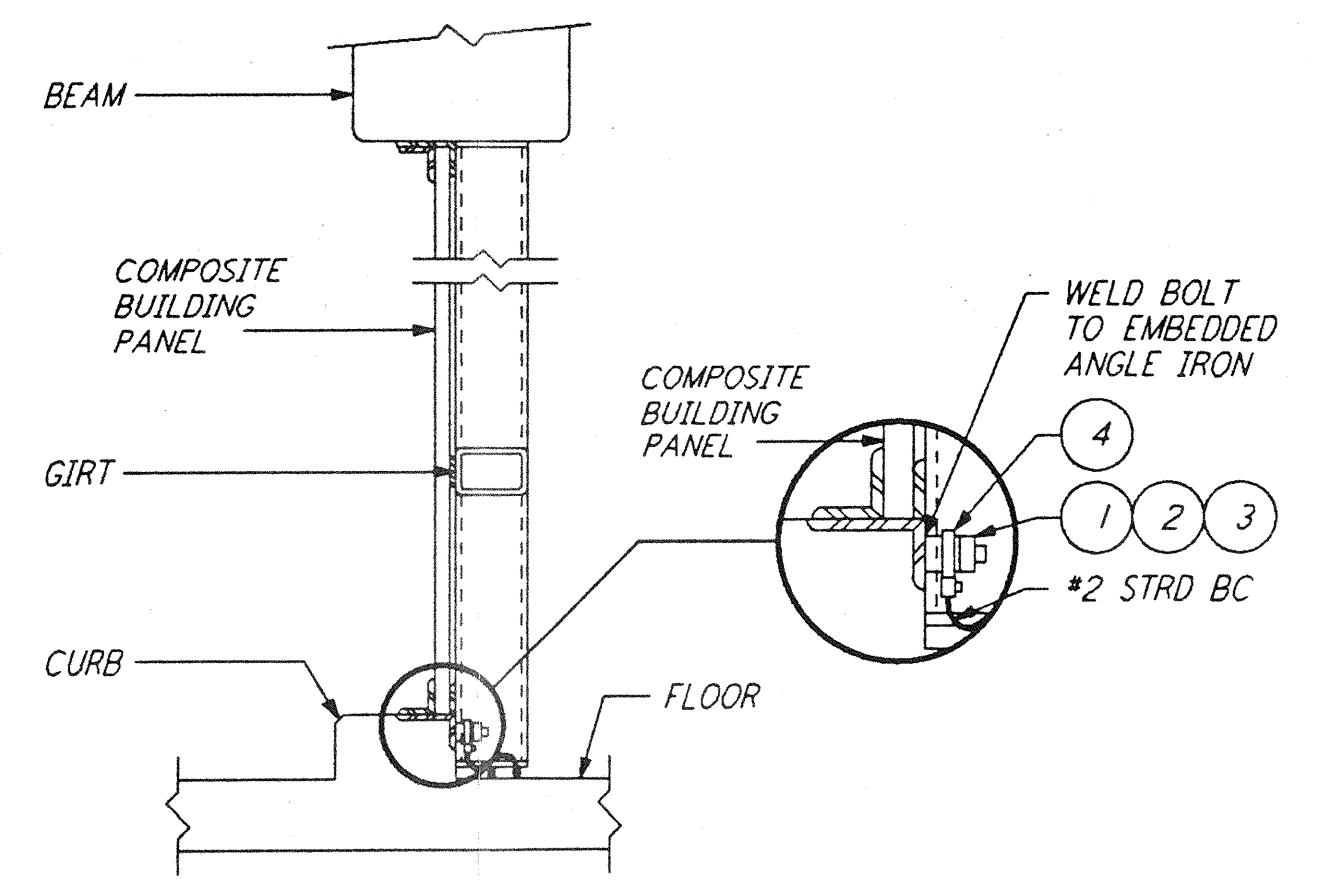

LIST OF MATERIAL

ITEM NO.	QTY	DESCRIPTION
1	1	BOLT, 3/8\"/>
2	1	LOCKWASHER, 3/8\"/>
3	1	NUT, 3/8\"/>
4	1	LUG, BOLTED CLAMP TYPE, BRONZE

COMPOSITE BUILDING PANEL GROUNDING (3) REF
 N. T. S.

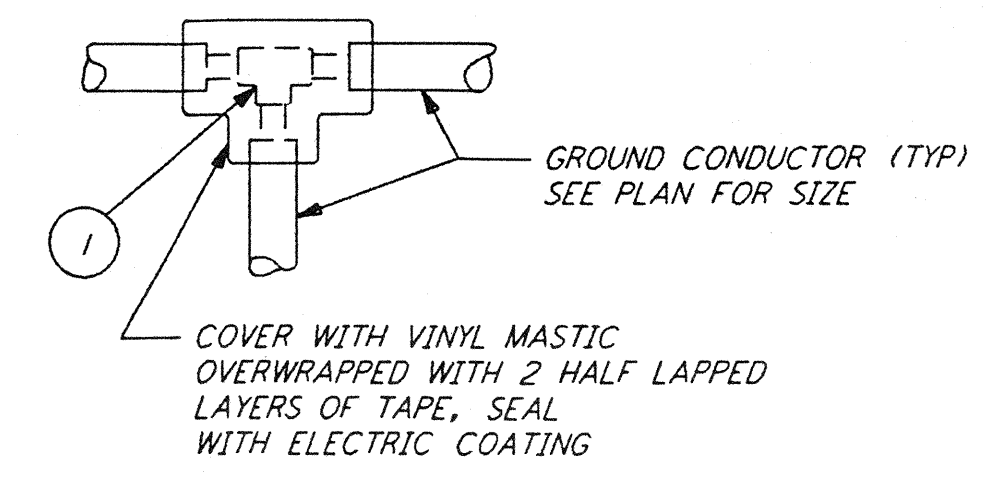

WIRE TO WIRE
 *A THERMAL CONNECTION

TYPE	WIRE SIZE	RUN	TAP
A	#4/0	#4/0	#4/0
B	#4/0	#2/0	#2/0
C	#4/0	#2	#2
D	#2	#2	#2
E	#2	#4	#4
F	#2/0	#2/0	#2/0
G	#2/0	#2	#2
H	#1/0	#1/0	#1/0

BOLTED CONNECTION
 *B CONNECTION

TYPE	WIRE SIZE	HOLE DIA.
A	#8-#2/0	7/16"

TAPPED CONNECTION
 *C CONNECTION

TYPE	WIRE SIZE	TAPPED HOLE
A	#8-#2	3/8\"/>
B	#2-#2/0	1/2\"/>

LIST OF MATERIAL

ITEM NO.	QTY	DESCRIPTION
1	1	THERMAL WELD, GROUND, SIZE AS REQUIRED
2	1	GROUND CONNECTOR, CABLE TO BAR, SIZE AS REQUIRED
3	1	GROUND POST, SIZE AS REQUIRED
4	AR	TYPE "TW" INSULATED GREEN GROUND WIRE (UNLESS OTHERWISE NOTED)

GROUNDING CONNECTIONS (4) REF
 N. T. S.

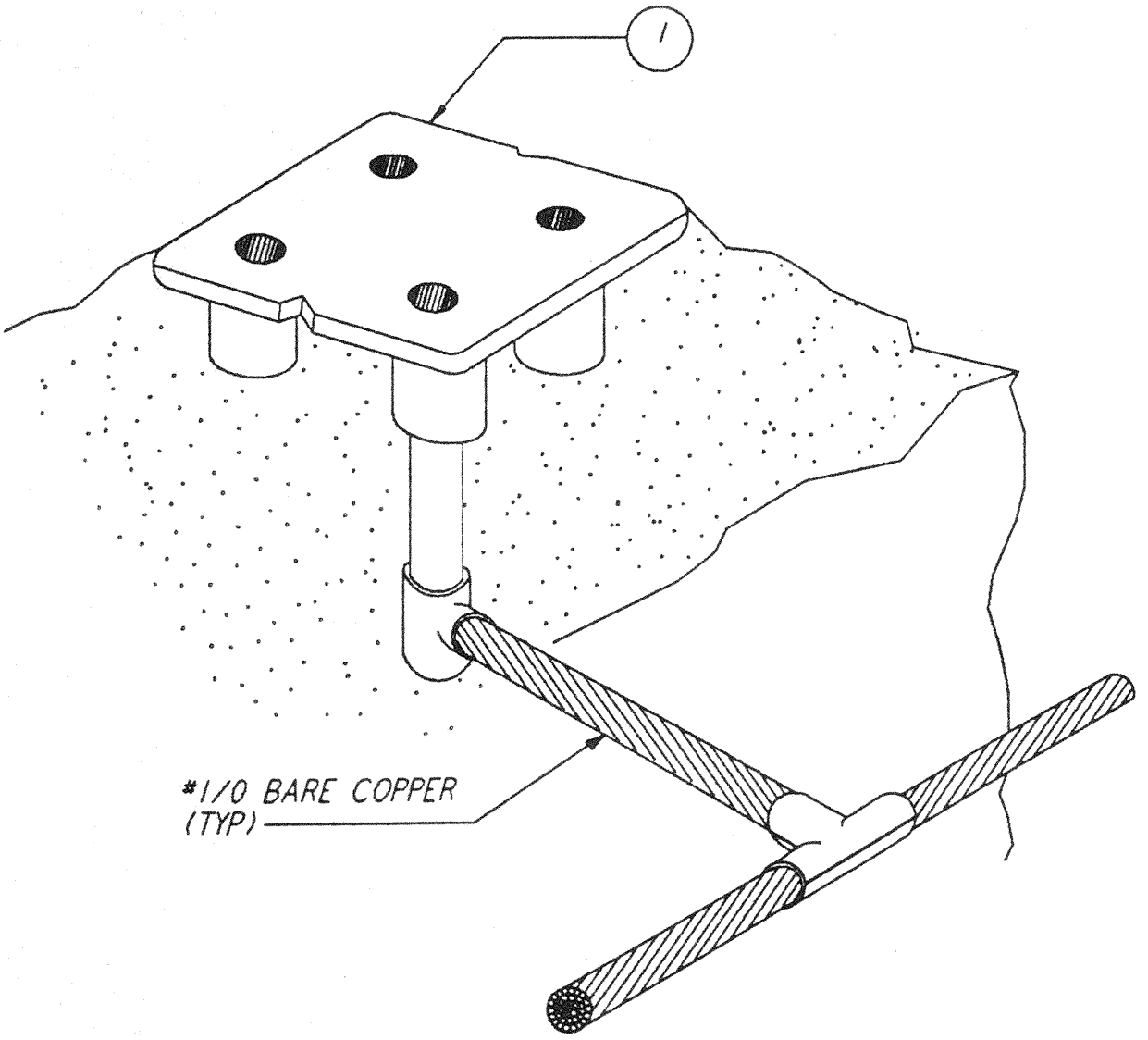

LIST OF MATERIAL

ITEM NO.	QTY	DESCRIPTION
1	1	GROUND PLATE, FLUSH, CADWELD #B16420

FLUSH FLOOR GROUND PLATE (5) REF
 N. T. S.

REFERENCES	REVISIONS	NO.	DATE	BY	CHKD	ENGR	PROJ	DESCRIPTION

ISSUED FOR CONSTRUCTION

DRAWN	M. M.	11-15-96
CHECKED	JCL	7-24-96
ENGINEER	RL	10-25-96
PROJ	SDM	11/15/96

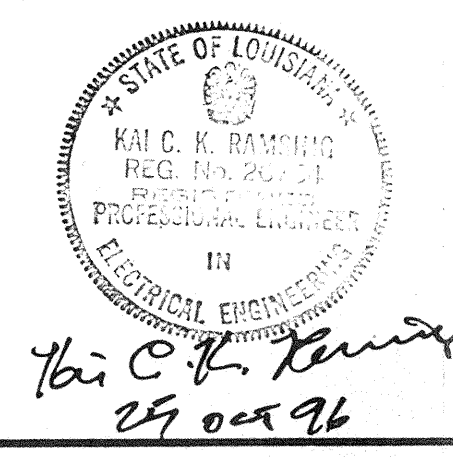

PARSONS
 100 WEST WALNUT STREET
 PASADENA, CALIFORNIA

LIGO
 CALIFORNIA INSTITUTE OF TECHNOLOGY
 MASSACHUSETTS INSTITUTE OF TECHNOLOGY

LASER INTERFEROMETER
 GRAVITATIONAL-WAVE OBSERVATORY
 SITE NO. 2 - LIVINGSTON, LOUISIANA

TITLE	SCALE	CONTRACT NUMBER	PROJECT NUMBER
ELECTRICAL GROUNDING DETAILS SHEET I	NONE	PP150969	8094

LA-E-405