

This document and the design it covers are the property of PARSONS. They are loaned only with the borrower's expressed written agreement that they will not be reproduced, copied, loaned, exhibited, or used in any other way, except by written consent from PARSONS to the borrower.

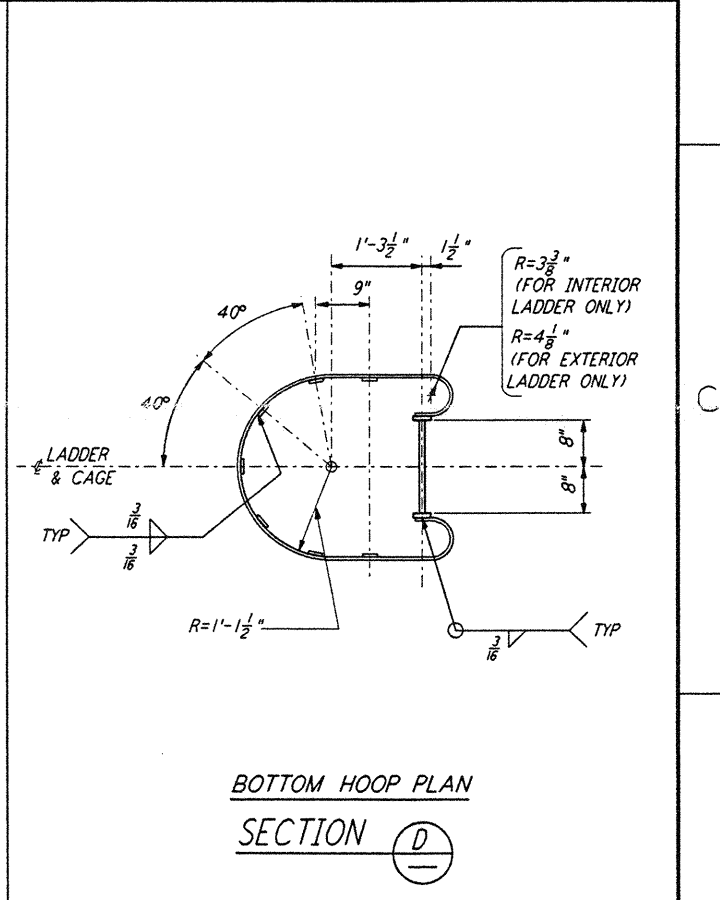
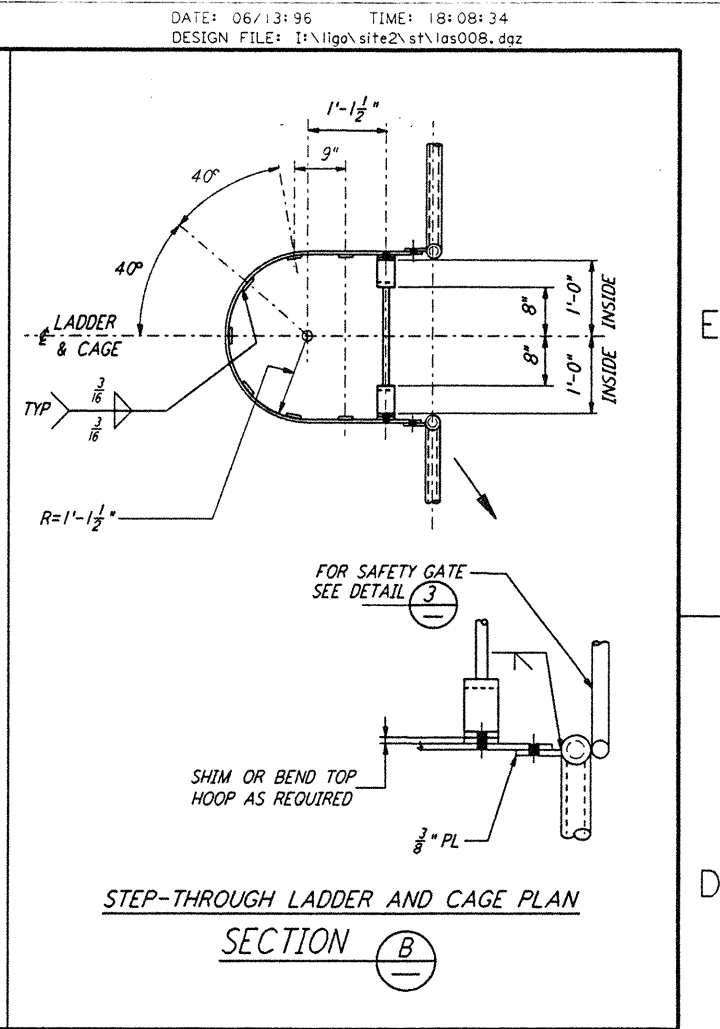
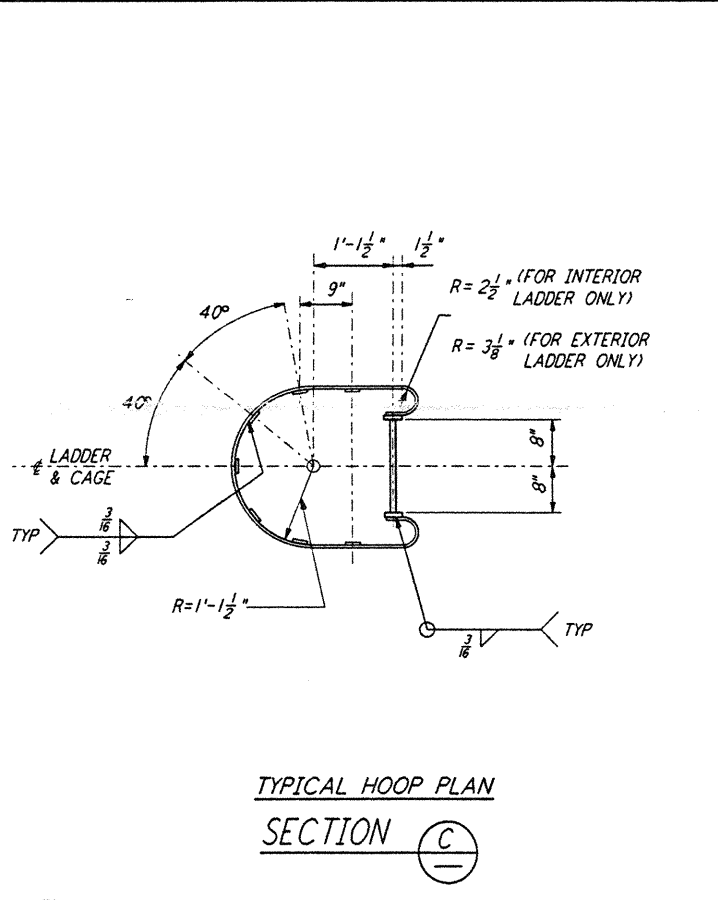
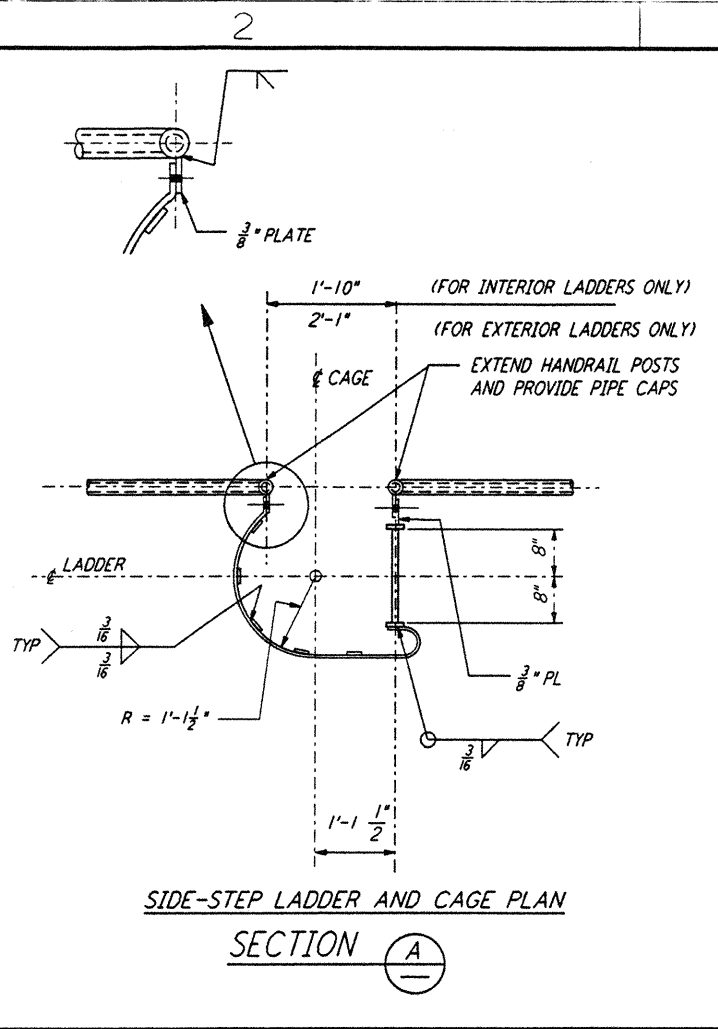
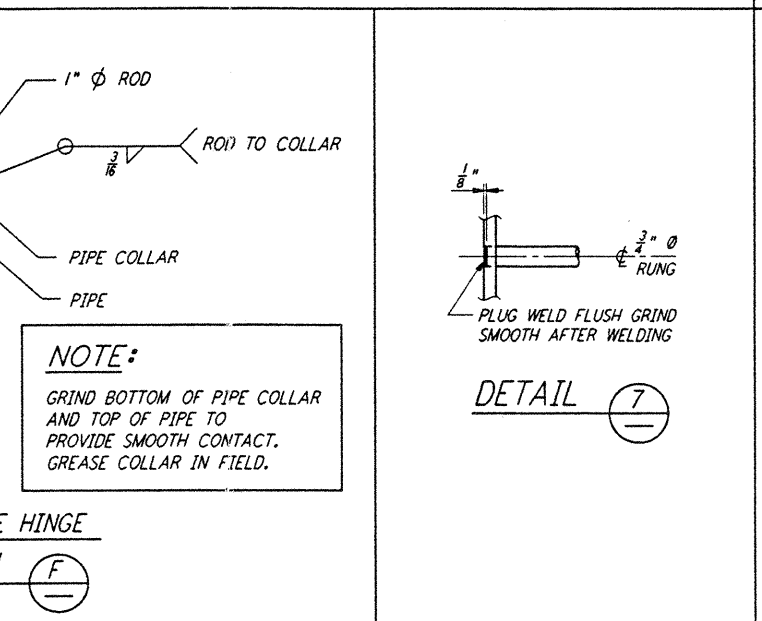
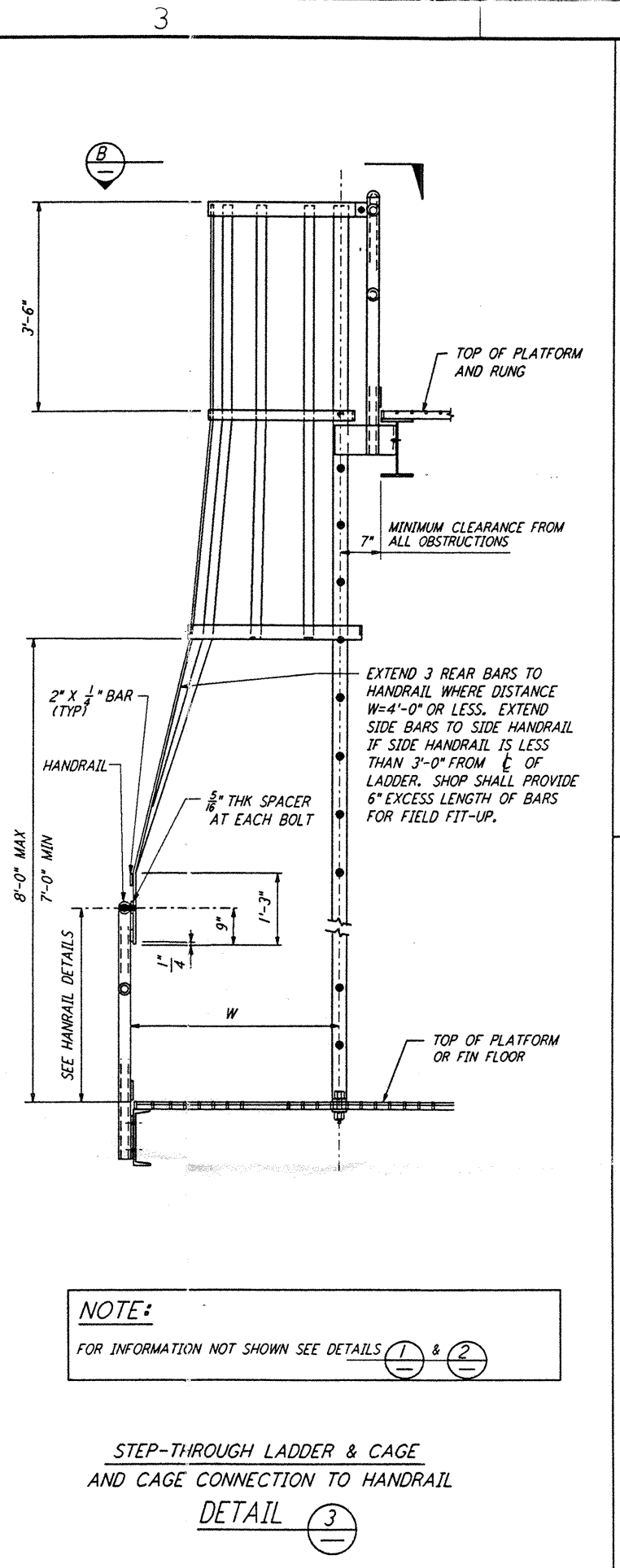
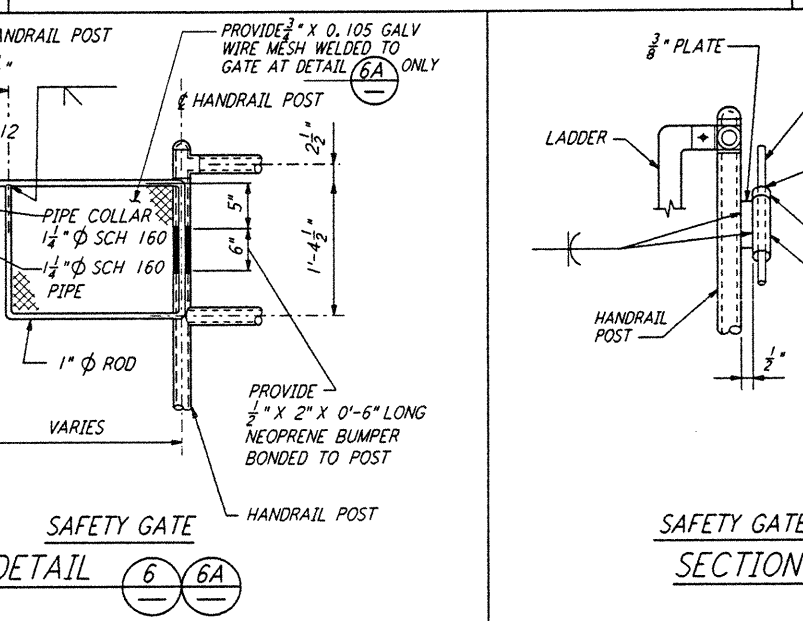
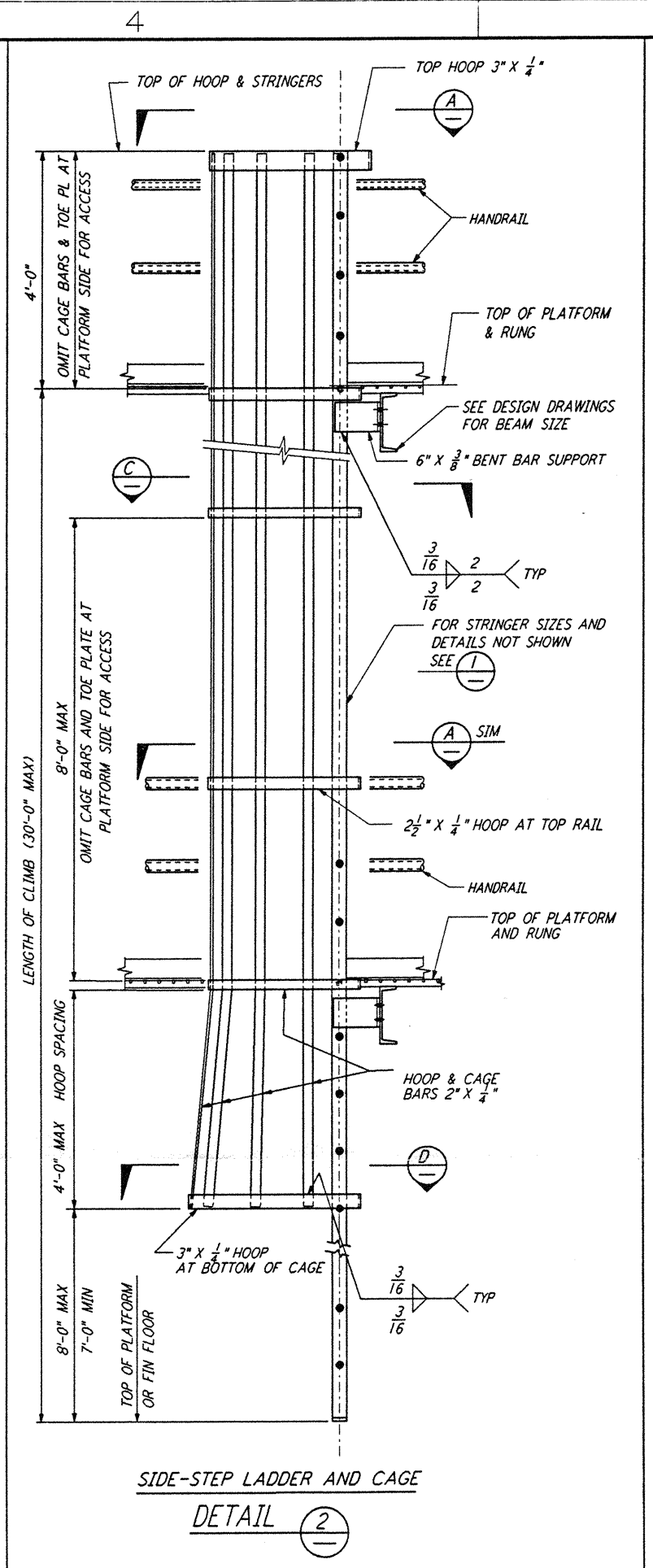
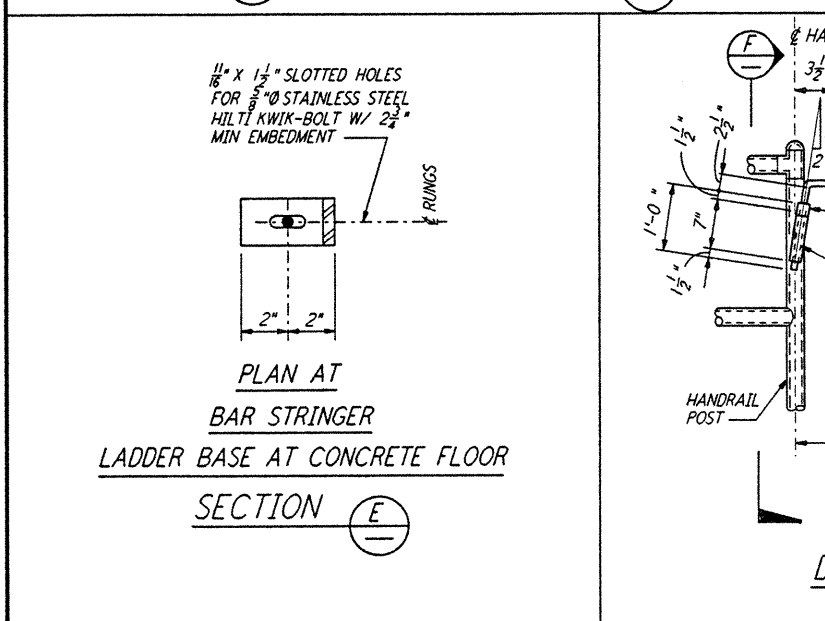
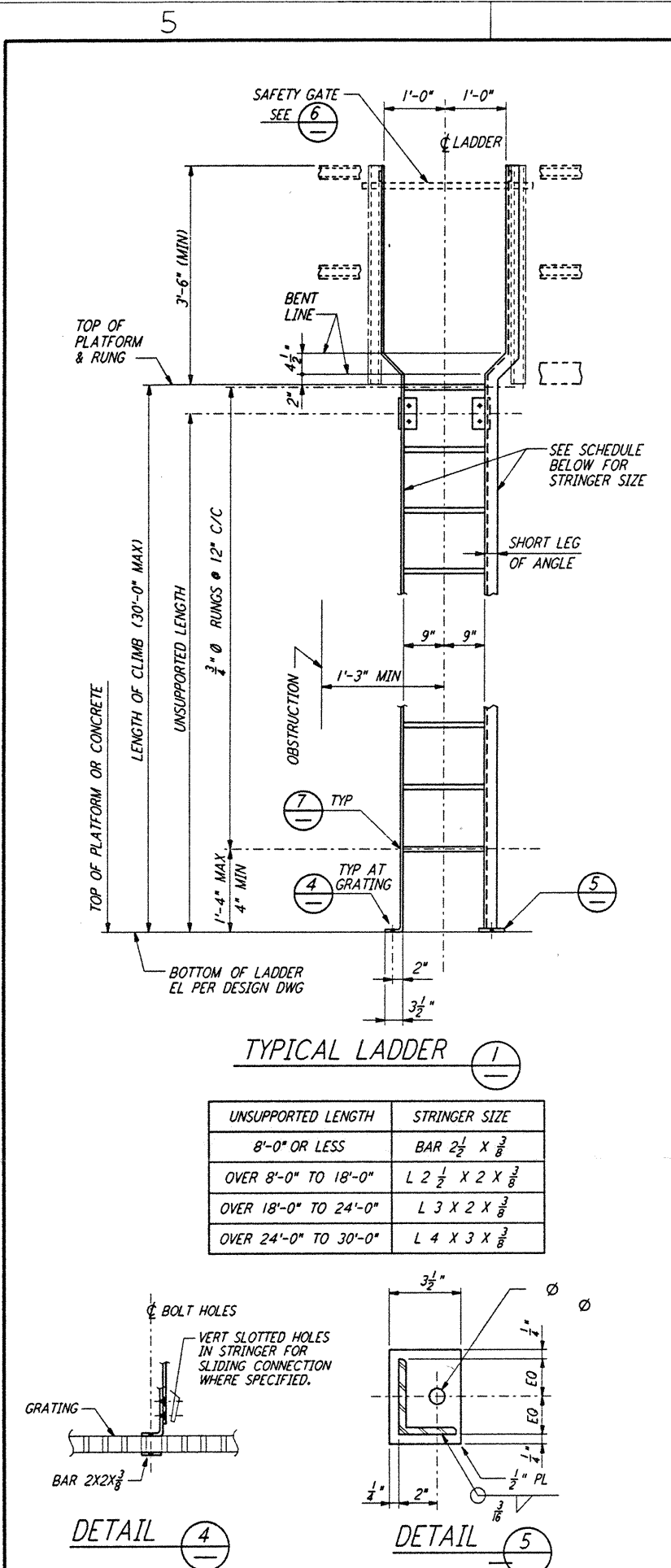

- NOTES:**
- FOR GENERAL NOTES, ABBREVIATIONS AND SYMBOLS SEE DRAWING LA-5-001.
 - ALL BURRS AND SHARP EDGES SHALL BE REMOVED FROM THE LADDERS, CAGES AND SAFETY BARS.
 - ALL INTERMEDIATE CAGE HOOPS SHALL BE SPACED EQUALLY AND SHALL NOT EXCEED 4 FEET. IF CAGE LENGTH EXCEEDS 20 FEET, LADDER MUST BE EQUIPPED WITH A 3" HOOP PREFERABLY AT THE MIDWAY POINT OF THE CAGE.
 - LADDERS SERVING PLATFORMS OR LANDINGS 4 FEET OR MORE ABOVE GRADE AND ALL PLATFORMS REQUIRING A RAILING SHALL BE EQUIPPED WITH A SAFETY GATE.

LIGO-D960914-B-O

NO.	DATE	BY	CHKD	ENGR	PROJ	DESCRIPTION
B	6-14-96	MCS	GM	TM		FINAL DESIGN REVIEW
A	10-31-95					PRELIMINARY DESIGN REVIEW

DRAWN	MCS
CHECKED	
ENGINEER	
PROJ	

PARSONS
 100 WEST WALNUT STREET
 PASADENA, CALIFORNIA

LIGO
 CALIFORNIA INSTITUTE OF TECHNOLOGY
 MASSACHUSETTS INSTITUTE OF TECHNOLOGY

LASER INTERFEROMETER
 GRAVITATIONAL-WAVE OBSERVATORY
 SITE NO. 2 - LIVINGSTON, LOUISIANA

TITLE	STRUCTURAL STANDARD	SCALE	NONE	CONTRACT NUMBER	PP150969	PROJECT NUMBER	8094
SHEET NUMBER	LA-S-008	REVISIONS					

FIG. 10. 11. 12. 13. 14. 15. 16. 17. 18. 19. 20. 21. 22. 23. 24. 25. 26. 27. 28. 29. 30. 31. 32. 33. 34. 35. 36. 37. 38. 39. 40. 41. 42. 43. 44. 45. 46. 47. 48. 49. 50. 51. 52. 53. 54. 55. 56. 57. 58. 59. 60. 61. 62. 63. 64. 65. 66. 67. 68. 69. 70. 71. 72. 73. 74. 75. 76. 77. 78. 79. 80. 81. 82. 83. 84. 85. 86. 87. 88. 89. 90. 91. 92. 93. 94. 95. 96. 97. 98. 99. 100.