

- NOTES:**
- BOLT MATERIAL SHALL BE IN ACCORDANCE WITH ASTM A307, UNLESS OTHERWISE SPECIFIED.
  - USE UNIFIED NATIONAL COARSE THREAD, CLASS 2 FIT.
  - USE HEAVY DOUBLE CHAMFER HEX NUTS UP TO 1", AND HEAVY FLAT FACE HEX NUTS LARGER THAN 1".
  - PROVIDE 1 HEX NUT FOR EACH BOLT, UNLESS OTHERWISE NOTED ON DESIGN DRAWINGS.
  - PLATE WASHER MATERIAL SHALL BE ASTM A36, UNLESS OTHERWISE NOTED.
  - FABRICATOR SHALL BUNDLE AND TAG BOLTS BY INDIVIDUAL FOUNDATIONS OR MEMBERS. TAGS SHALL BE WEATHER RESISTANT, WITH MARKS AT LEAST 1/2" HIGH, AND FIRMLY WIRED TO BUNDLES.
  - SLEEVES SHALL NOT BE USED UNLESS SPECIFIED ON THE DESIGN DRAWINGS.

DIA D	PLATE WASHER	SLEEVE IF REQD		THREAD LENGTH	DIA D
		DIA	LENGTH		
1/2"		2"	5"	1 1/2"	1/2"
3/8"		2"	5"	2 1/2"	3/8"
1/2"		2"	7"	2 1/2"	1/2"
3/8"		2"	7"	2 7/8"	3/8"
1"	2 1/2" X 2 1/2" X 1/8"	3"	10"	3 1/2"	1"
1 1/8"	3" X 3" X 1/2"	3"	10"	3 5/8"	1 1/8"
1 1/2"	3 1/2" X 3 1/2" X 1/2"	3"	10"	4"	1 1/2"
1 3/8"	3 1/2" X 3 1/2" X 1/2"	4"	15"	4 3/8"	1 3/8"
1 1/2"	3 1/2" X 3 1/2" X 1/8"	4"	15"	4 1/2"	1 1/2"

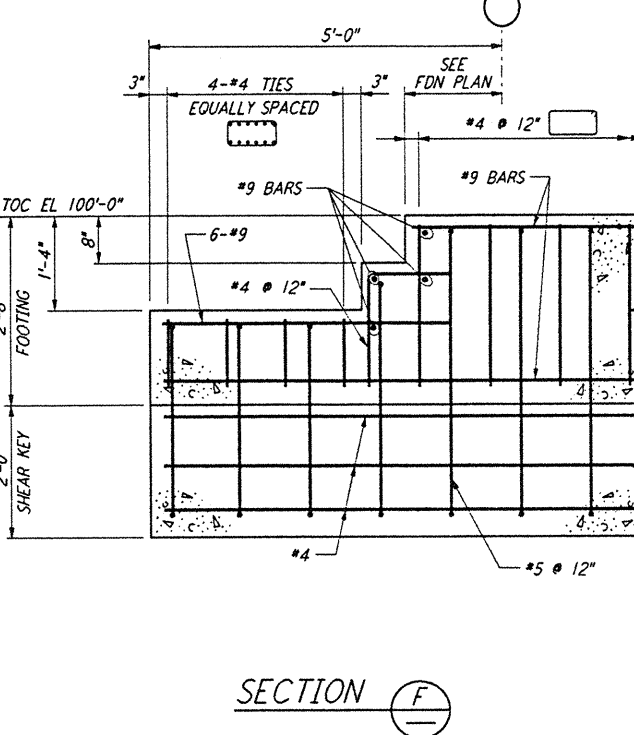
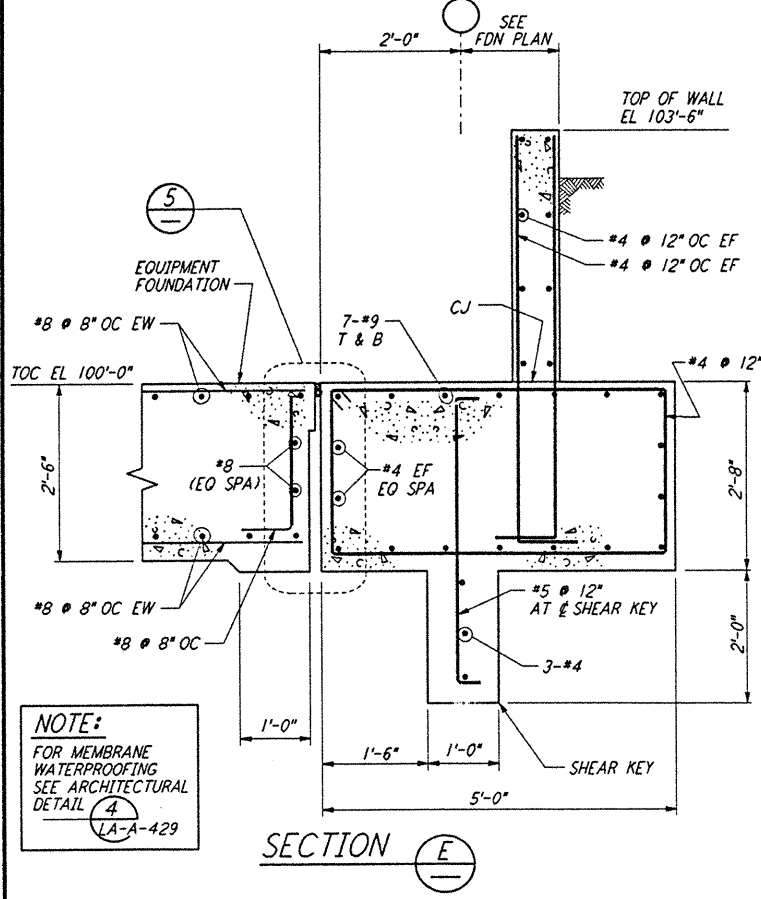
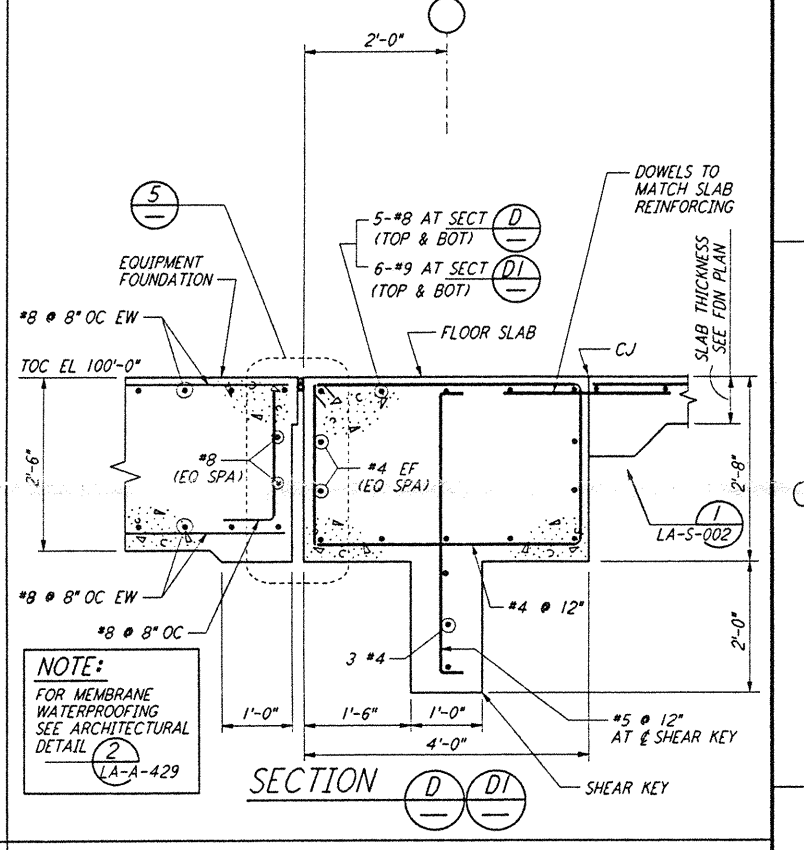
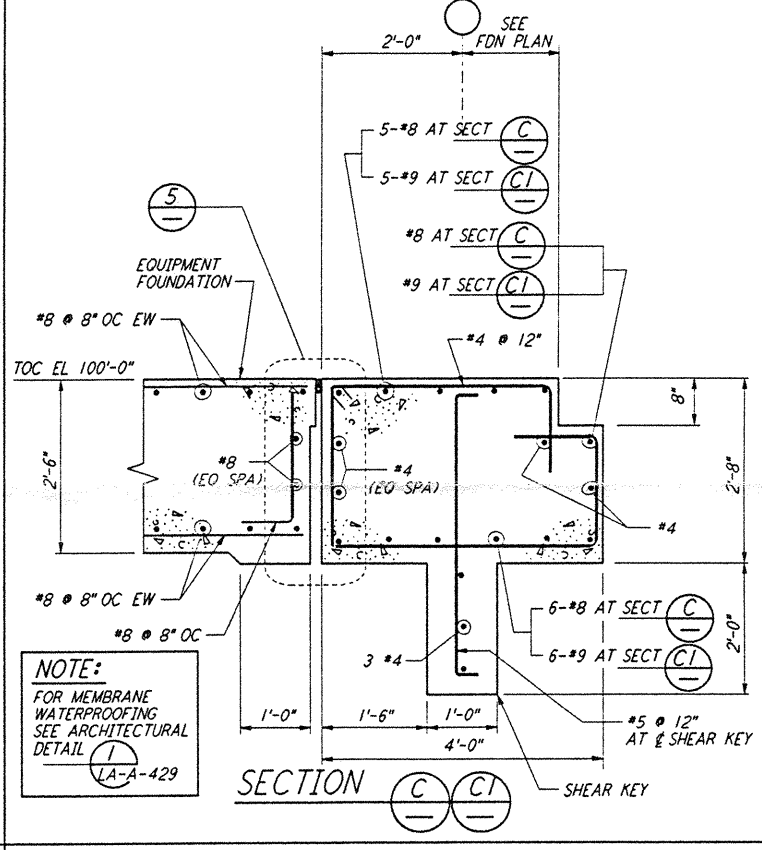
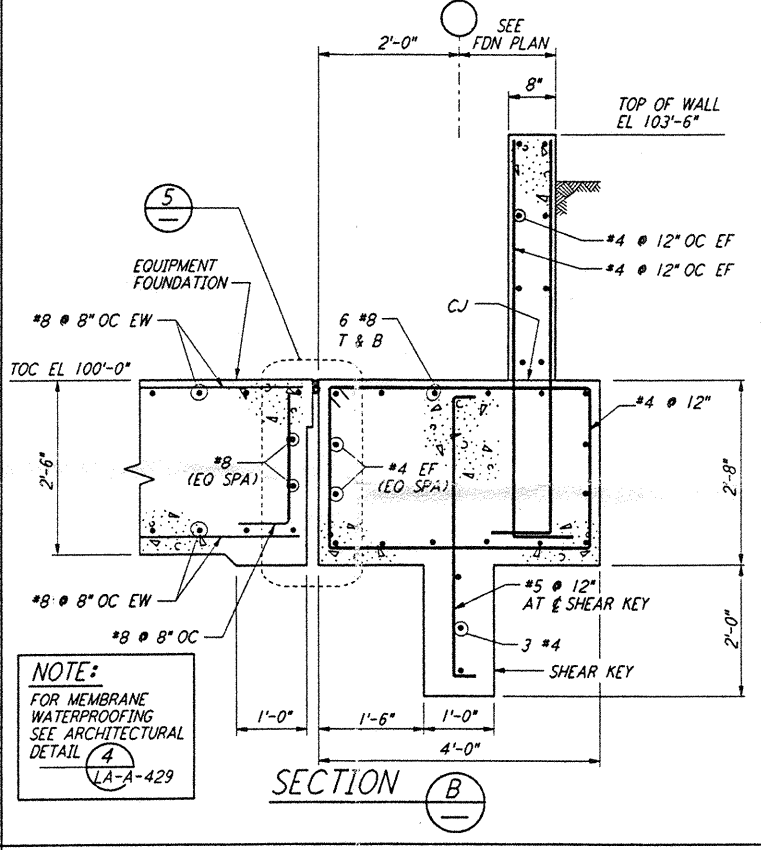
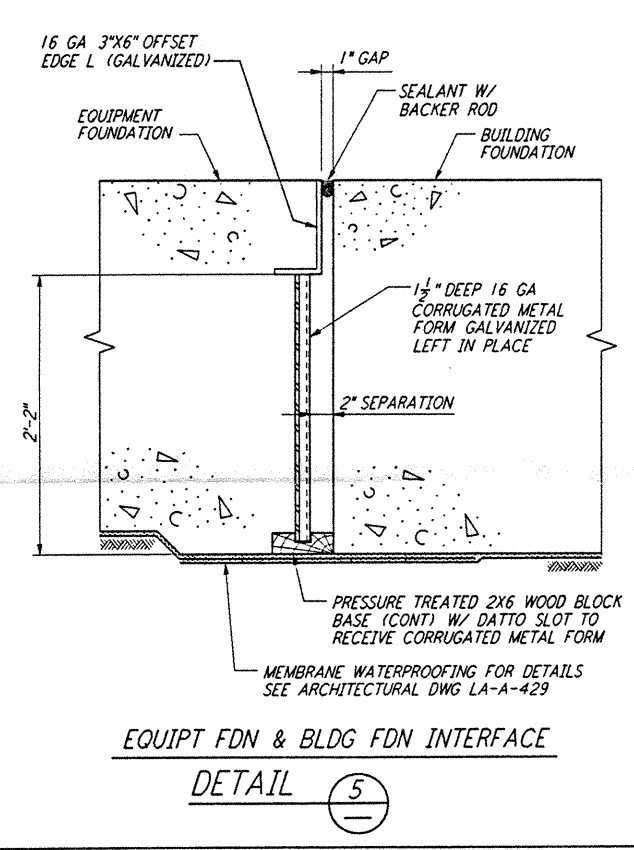
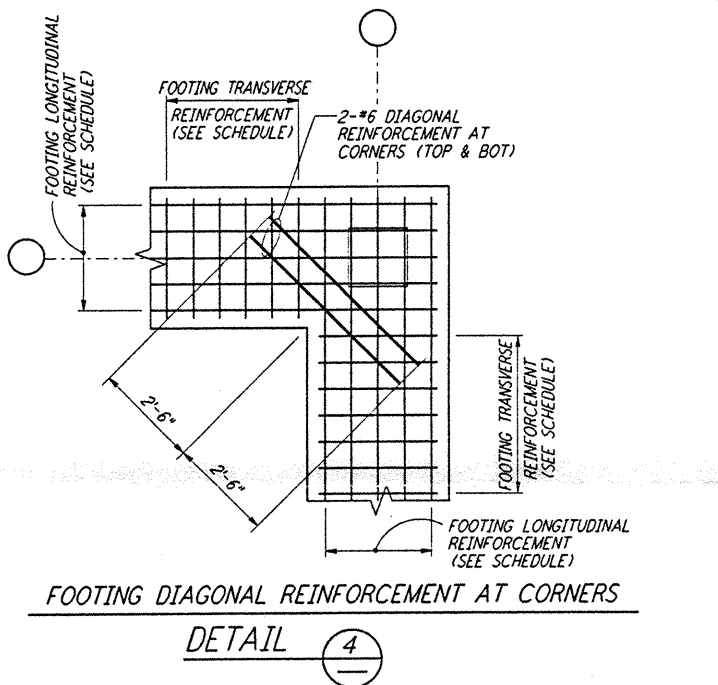
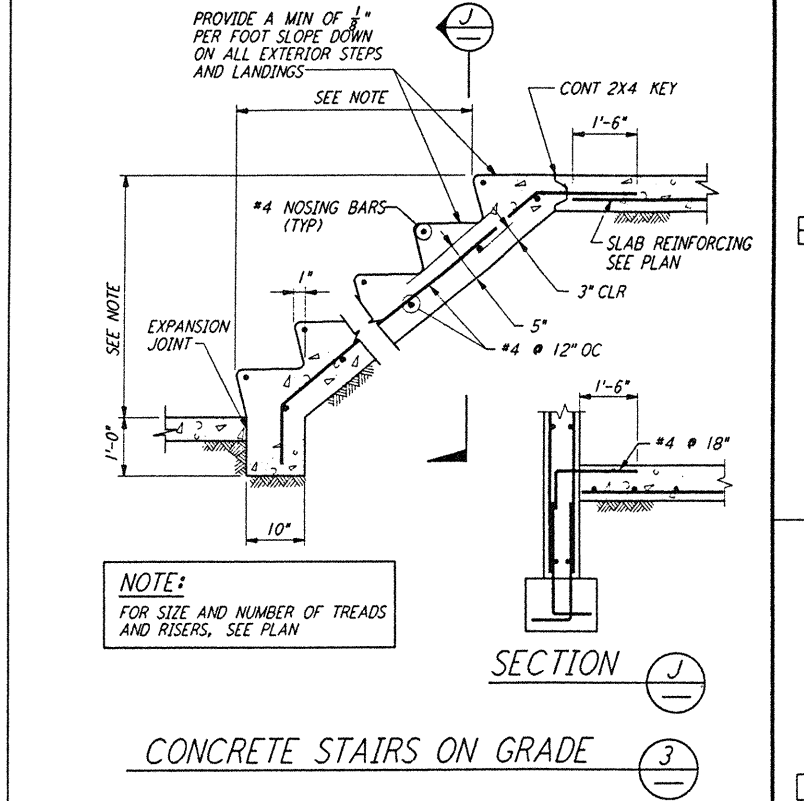
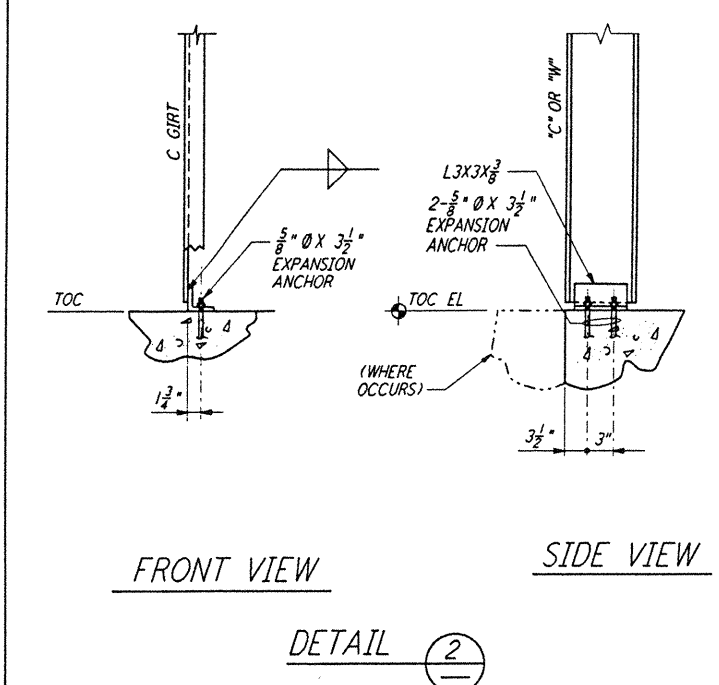
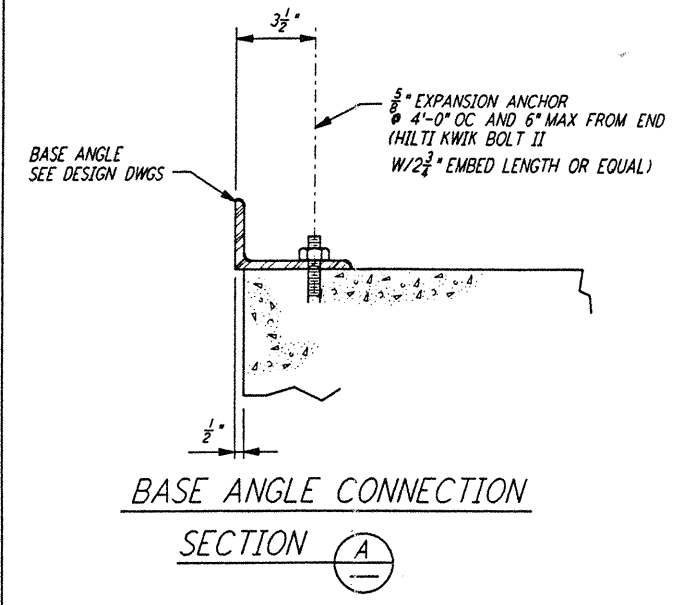
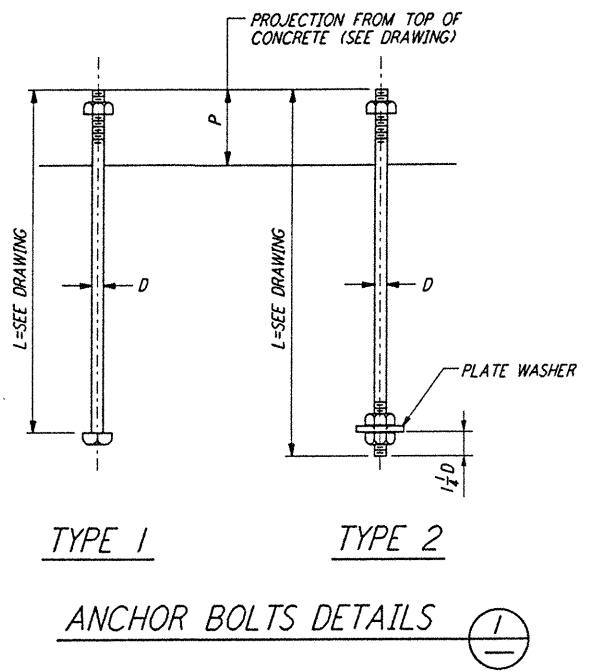

**NOTE:**  
 1. FOR GENERAL NOTES, ABBREVIATIONS AND SYMBOLS SEE DRAWING LA-S-001.

This document and the design it covers are the property of PARSONS. They are loaned only with the borrower's expressed written agreement that they will not be reproduced, copied, loaned, exhibited, or used in any other way, except by written consent from PARSONS to the borrower.

NO.	DATE	BY	CHKD	ENGR	PROJ	DESCRIPTION

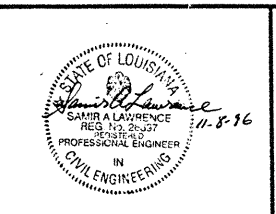

**PARSONS**  
 100 WEST WALNUT STREET  
 PASADENA, CALIFORNIA

**LIGO**  
 CALIFORNIA INSTITUTE OF TECHNOLOGY  
 MASSACHUSETTS INSTITUTE OF TECHNOLOGY

LASER INTERFEROMETER  
 GRAVITATIONAL-WAVE OBSERVATORY  
 SITE NO. 2 - LIVINGSTON, LOUISIANA

SCALE: NONE CONTRACT NUMBER: PP150969 PROJECT NUMBER: 8094  
 SHEET NUMBER: LA-S-003