

Pc. 10 Make from 1/4" thk. 304 ss plate

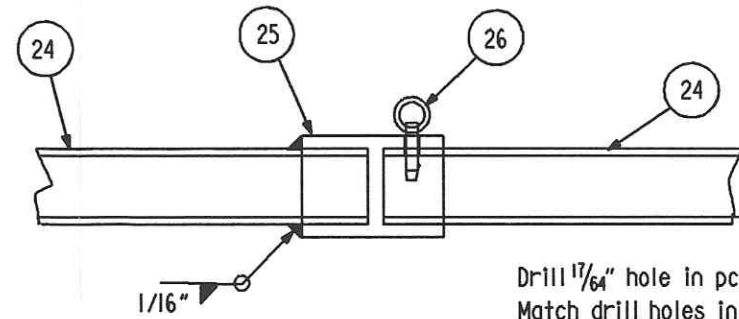
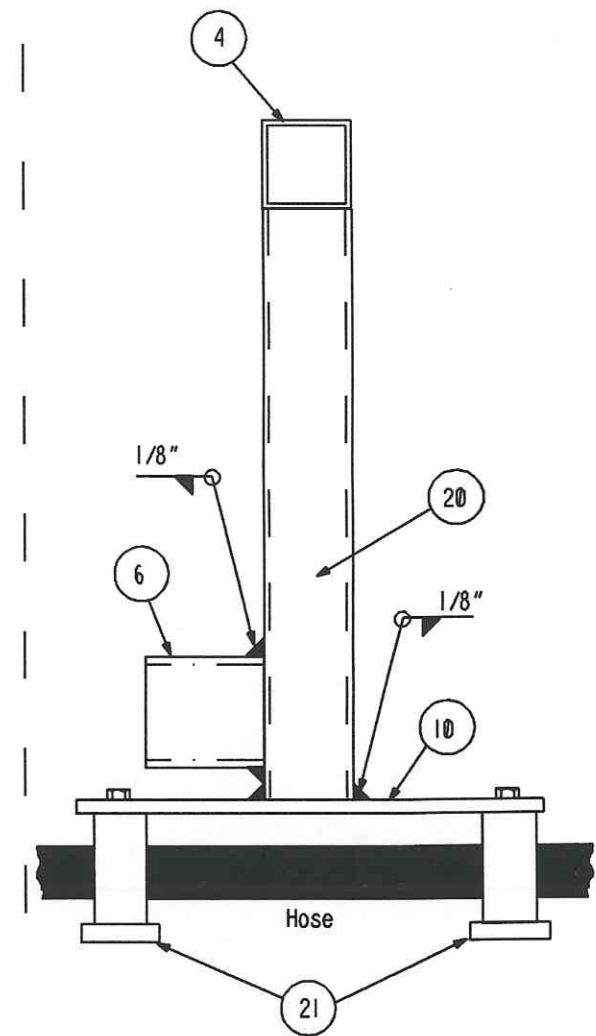
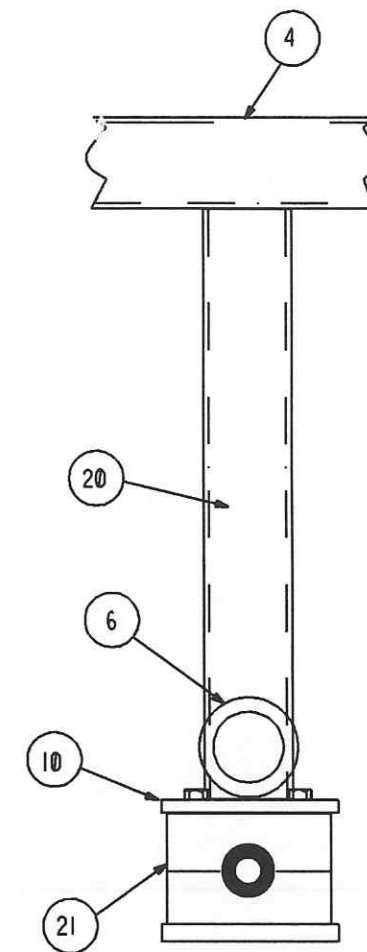

Push Pipe Assemblies (typical six places)

INDICATES CHANGE FROM PREVIOUS ISSUE

BY		DATE	CHKD	DATE	CHKD	DATE	REVISIONS			SUPPLIER'S / PURCHASER'S NO
BY		DATE	CHKD	DATE	CHKD	DATE	REVISIONS	LIGO-BEAM TUBE HANFORD, WA & LIVINGSTON, LA BEAM TUBE SECTION CLEANING EXTENSION ASSEMBLY		953571
BY		DATE	CHKD	DATE	CHKD	DATE	REVISIONS	CUSTOMER'S NO LIGO-C951080-00-B BY GLH CHKD SWP DATE 3-7-96 M. L. TELLALIAN ENGINEERING ASSIGNED		DWG ER302 REV 1
BY		DATE	CHKD	DATE	CHKD	DATE	REVISIONS	LIGO-D960516-01-B		