

NOTES:

1. BOLT MATERIAL SHALL BE IN ACCORDANCE WITH ASTM A307, UNLESS OTHERWISE SPECIFIED.
2. USE UNIFIED NATIONAL COARSE THREAD, CLASS 2 FIT.
3. USE HEAVY DOUBLE CHAMFER HEX NUTS UP TO 1", AND HEAVY FLAT FACE HEX NUTS LARGER THAN 1".
4. PROVIDE 1 HEX NUT FOR EACH BOLT, UNLESS OTHERWISE NOTED ON DESIGN DRAWINGS.
5. PLATE WASHER MATERIAL SHALL BE ASTM A36, UNLESS OTHERWISE NOTED.
6. FABRICATOR SHALL BUNDLE AND TAG BOLTS BY INDIVIDUAL FOUNDATIONS OR MEMBERS. TAGS SHALL BE WEATHER RESISTANT, WITH MARKS AT LEAST 1/2" HIGH, AND FIRMLY WIRED TO BUNDLES.
7. SLEEVES SHALL NOT BE USED UNLESS SPECIFIED ON THE DESIGN DRAWINGS.

ANCHOR BOLT SCHEDULE					
DIA D	PLATE WASHER	SLEEVE IF REQD		THREAD LENGTH	DIA D
		DIA	LENGTH		
1/2"		2"	5"	1 1/2"	1/2"
3/8"		2"	5"	2 1/2"	3/8"
3/4"		2"	7"	2 1/2"	3/4"
7/8"		2"	7"	2 1/2"	7/8"
1"	2 1/2" X 2 1/2" X 3/8"	3"	10"	3 1/2"	1"
1 1/4"	3" X 3" X 1/2"	3"	10"	3 3/8"	1 1/4"
1 1/2"	3 1/2" X 3 1/2" X 1/2"	3"	10"	4"	1 1/2"
1 3/4"	3 1/2" X 3 1/2" X 1/2"	4"	15"	4 1/2"	1 3/4"
1 1/2"	3 1/2" X 3 1/2" X 3/8"	4"	15"	4 3/4"	1 1/2"

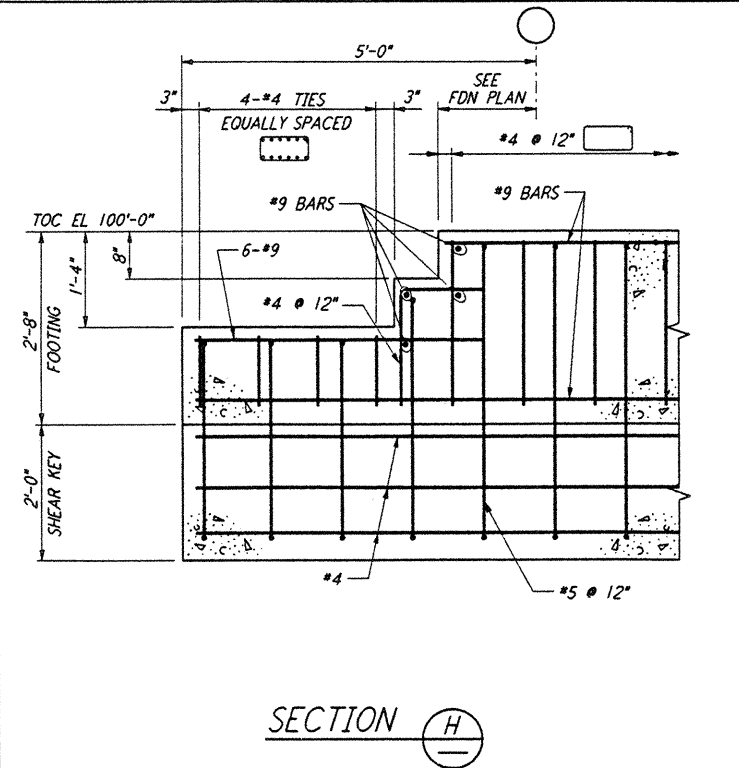
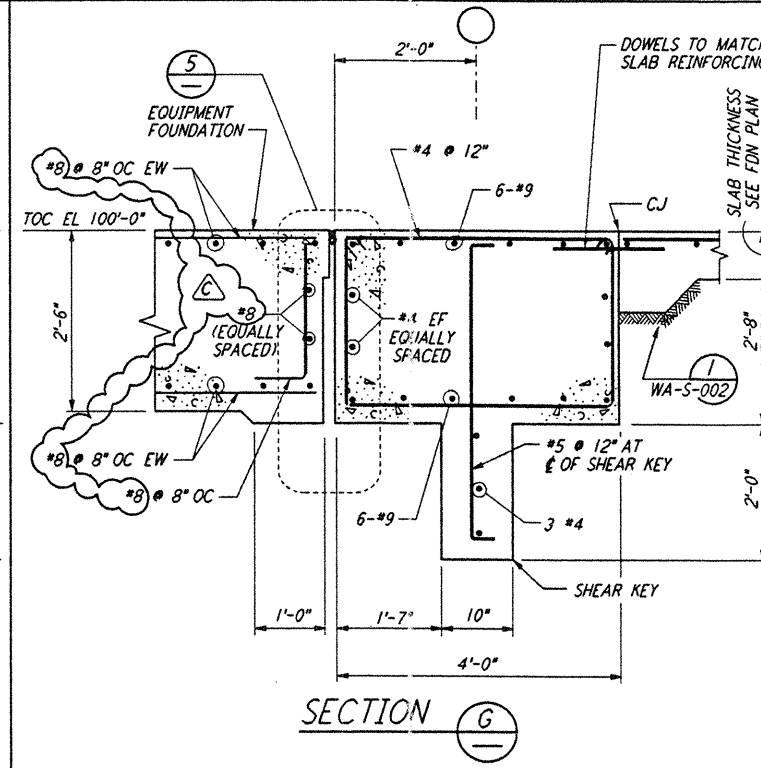
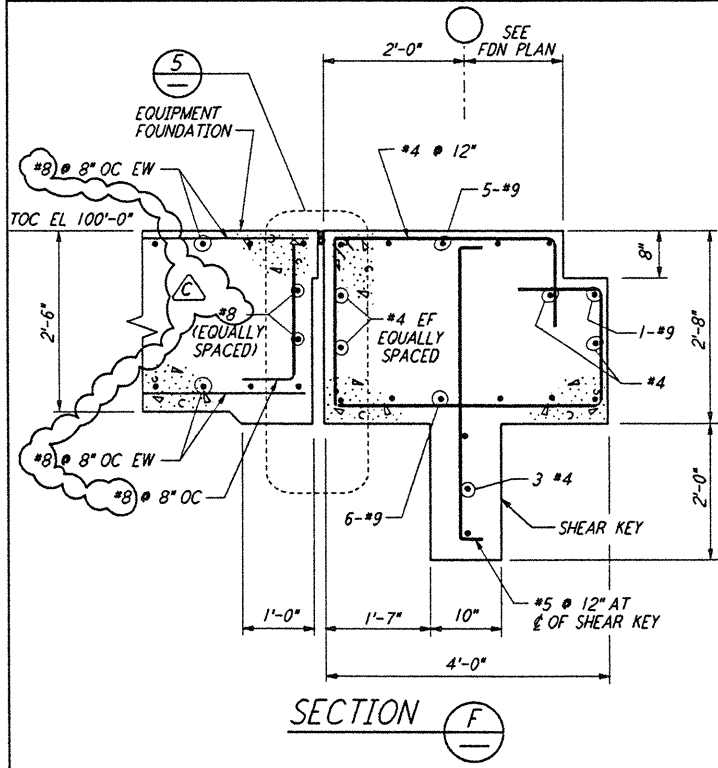
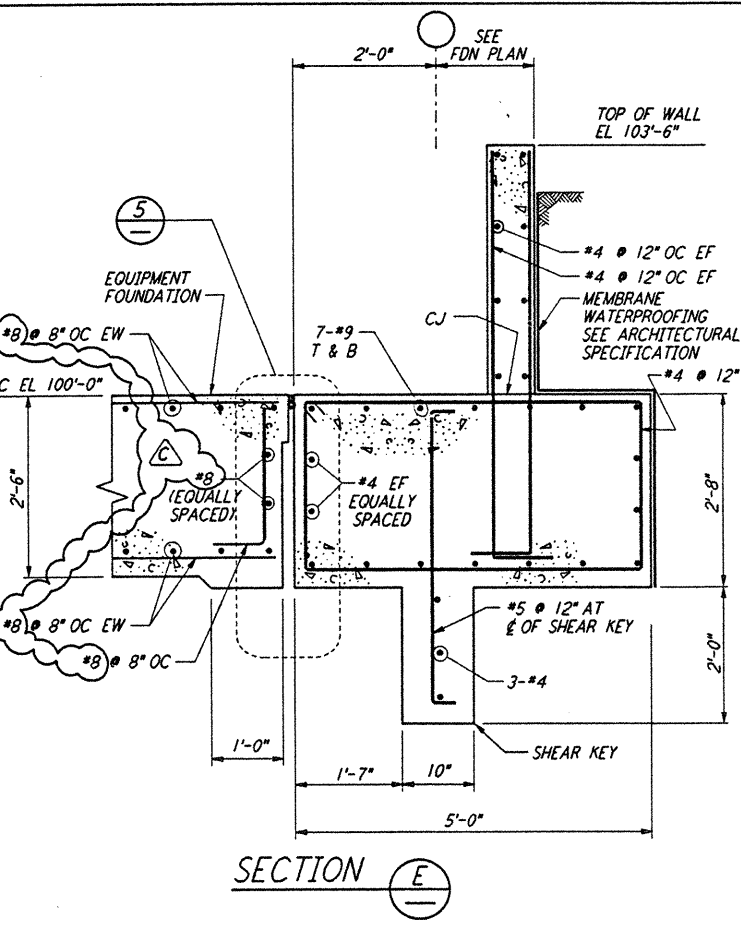
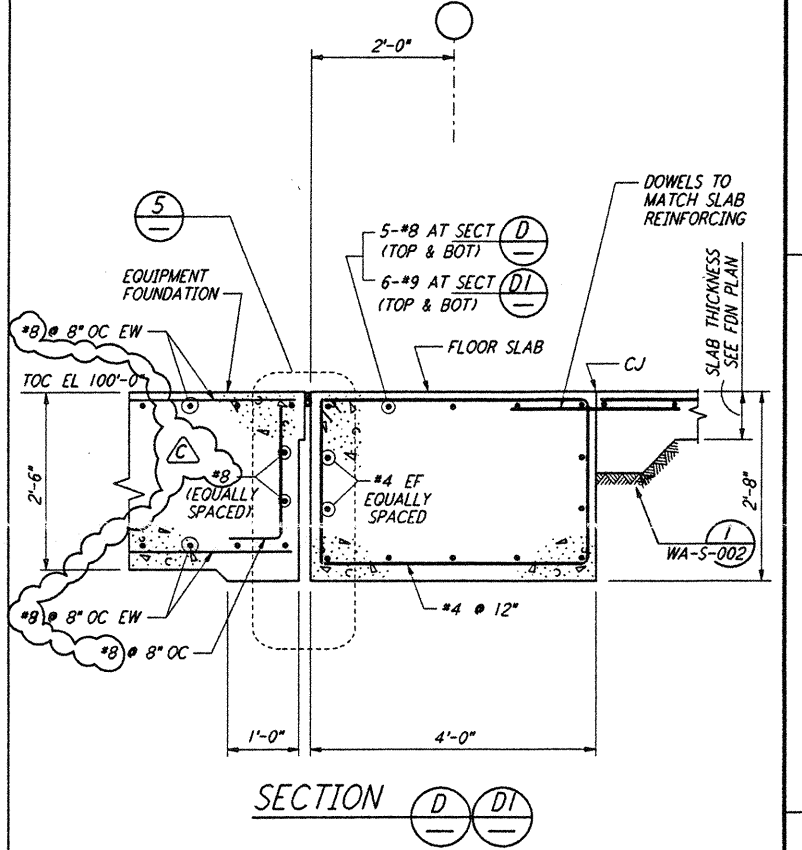
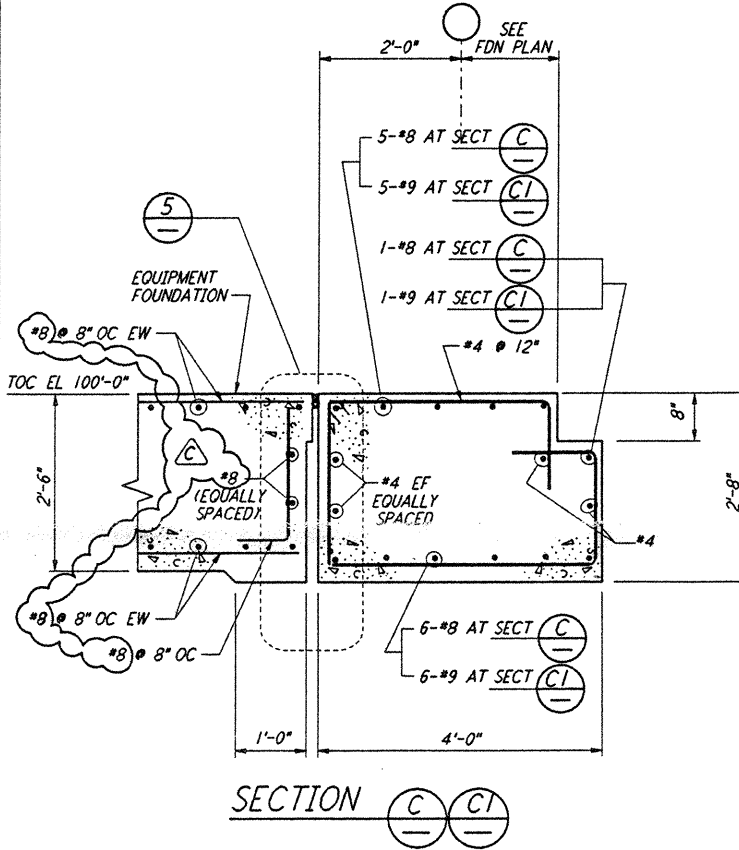
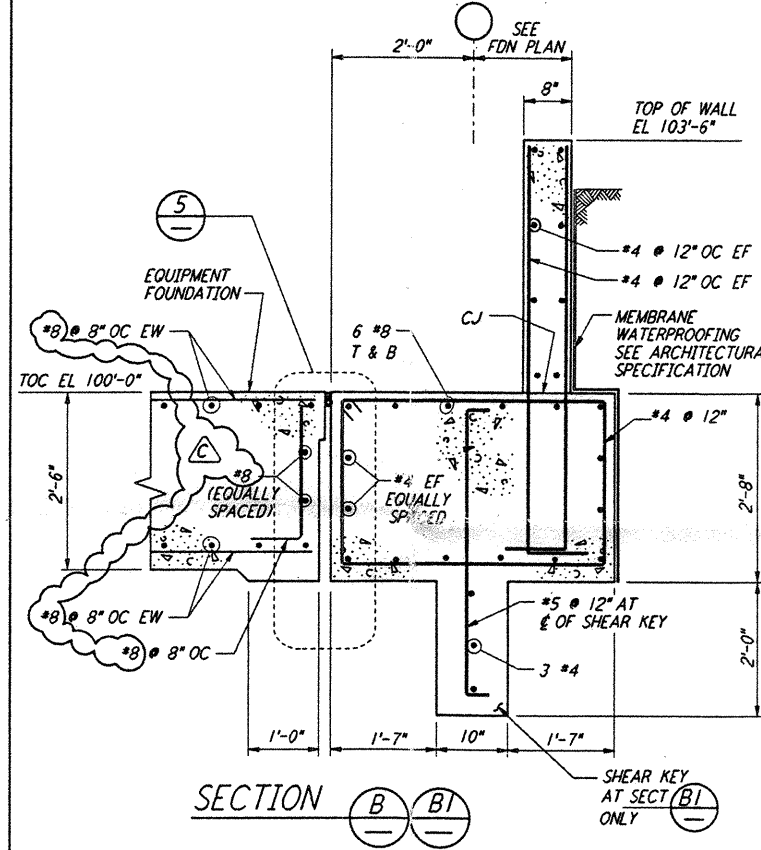
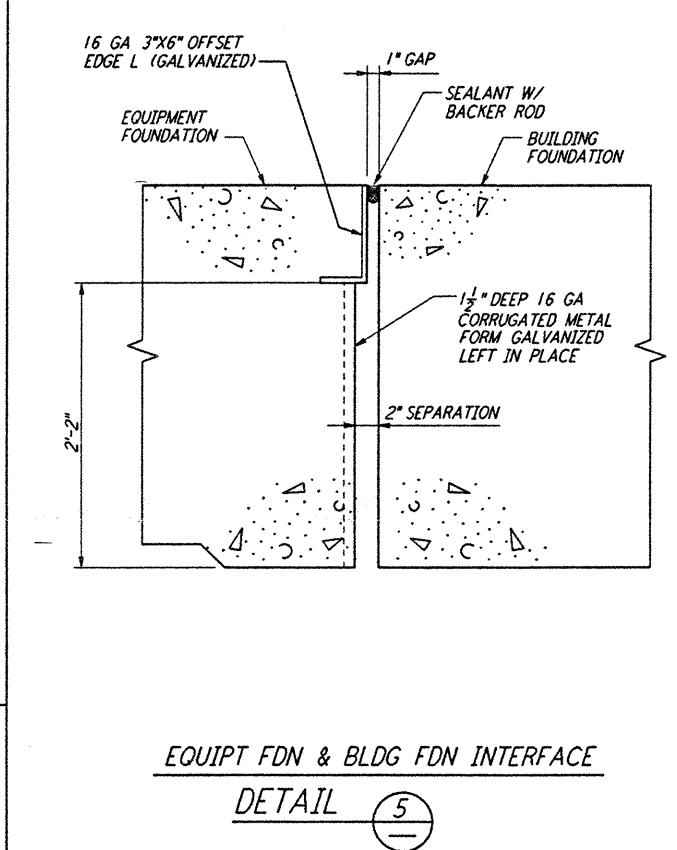
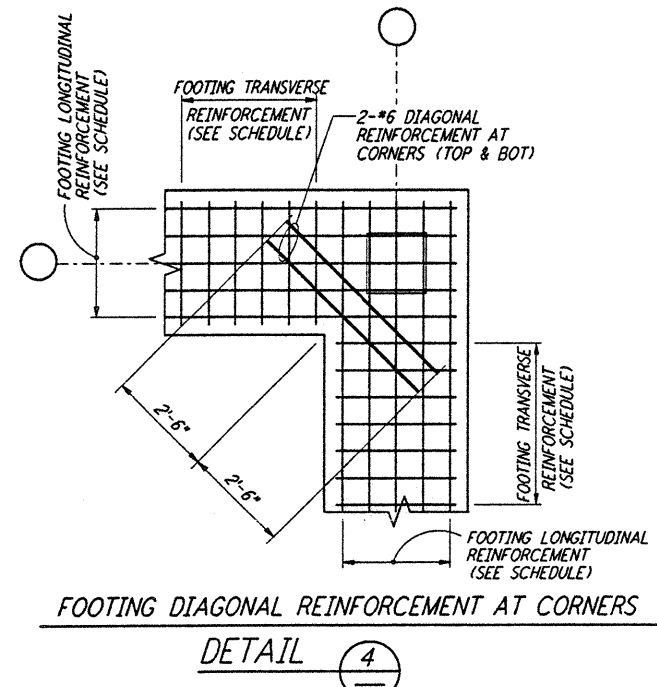
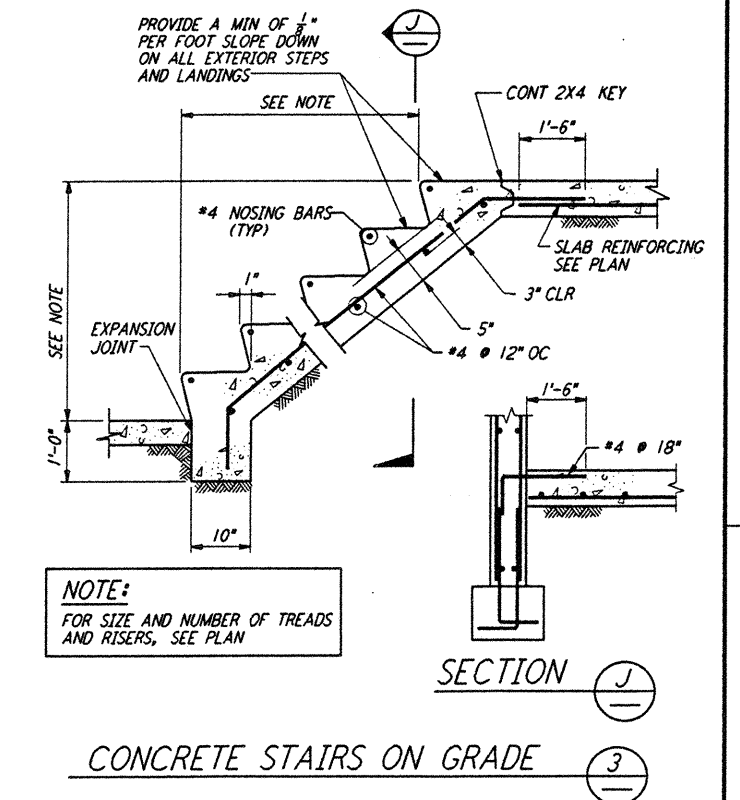
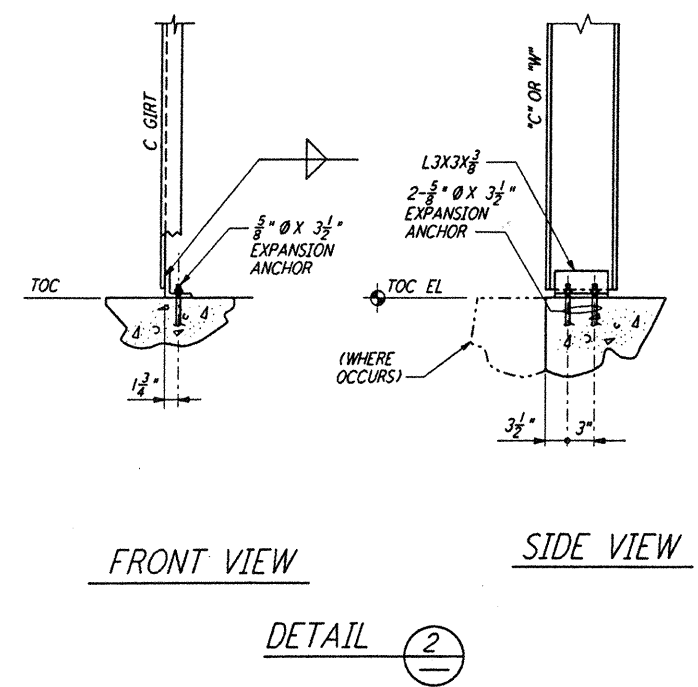
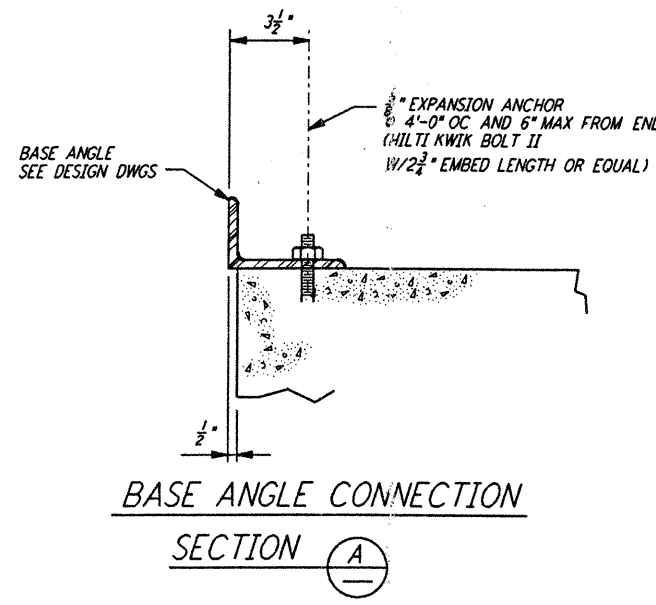
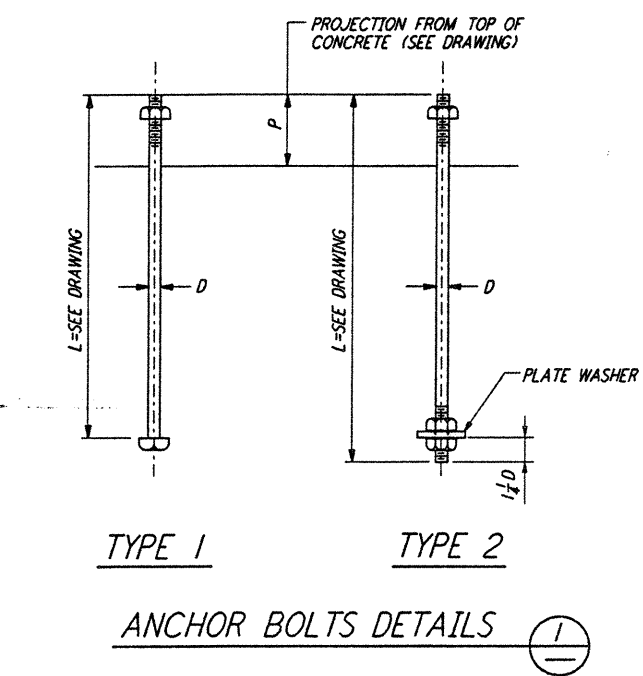

NOTES:
 1. FOR GENERAL NOTES, ABBREVIATIONS AND SYMBOLS, SEE DRAWING 5-001

NO.	DATE	BY	CHKD	ENGR	PROJ	DESCRIPTION
C	5-22-96	MCS	BP	TDN		BID ADDENDUM #2
B	4-19-96	MCS	DDM	BP	TDN	FINAL DESIGN REVIEW & BID
A	10-31-95				TDN	PRELIMINARY DESIGN REVIEW

DRAWN	MCS
CHECKED	
ENGINEER	
PROJ	

PARSONS
 100 WEST WALNUT STREET
 PASADENA, CALIFORNIA

LIGO
 CALIFORNIA INSTITUTE OF TECHNOLOGY
 MASSACHUSETTS INSTITUTE OF TECHNOLOGY

LASER INTERFEROMETER
 GRAVITATIONAL-WAVE OBSERVATORY
 SITE NO. 1 - HANFORD, WASHINGTON

STRUCTURAL
 STANDARD
 CONCRETE DETAILS SHEET 2

WA-S-003

not be reproduced, copied, loaned, exhibited, or used in any other way, except by written consent from PARSONS to the borrower.

This document and the design it covers are the property of PARSONS. They are loaned only with the borrower's expressed written agreement that they will

LIGO-D960288-C-0
 2015-05-20 10:00:00 AM