

NOTES:
 1. SEE SHEET WA-C-002 FOR GENERAL NOTES, LEGEND AND ABBREVIATIONS.

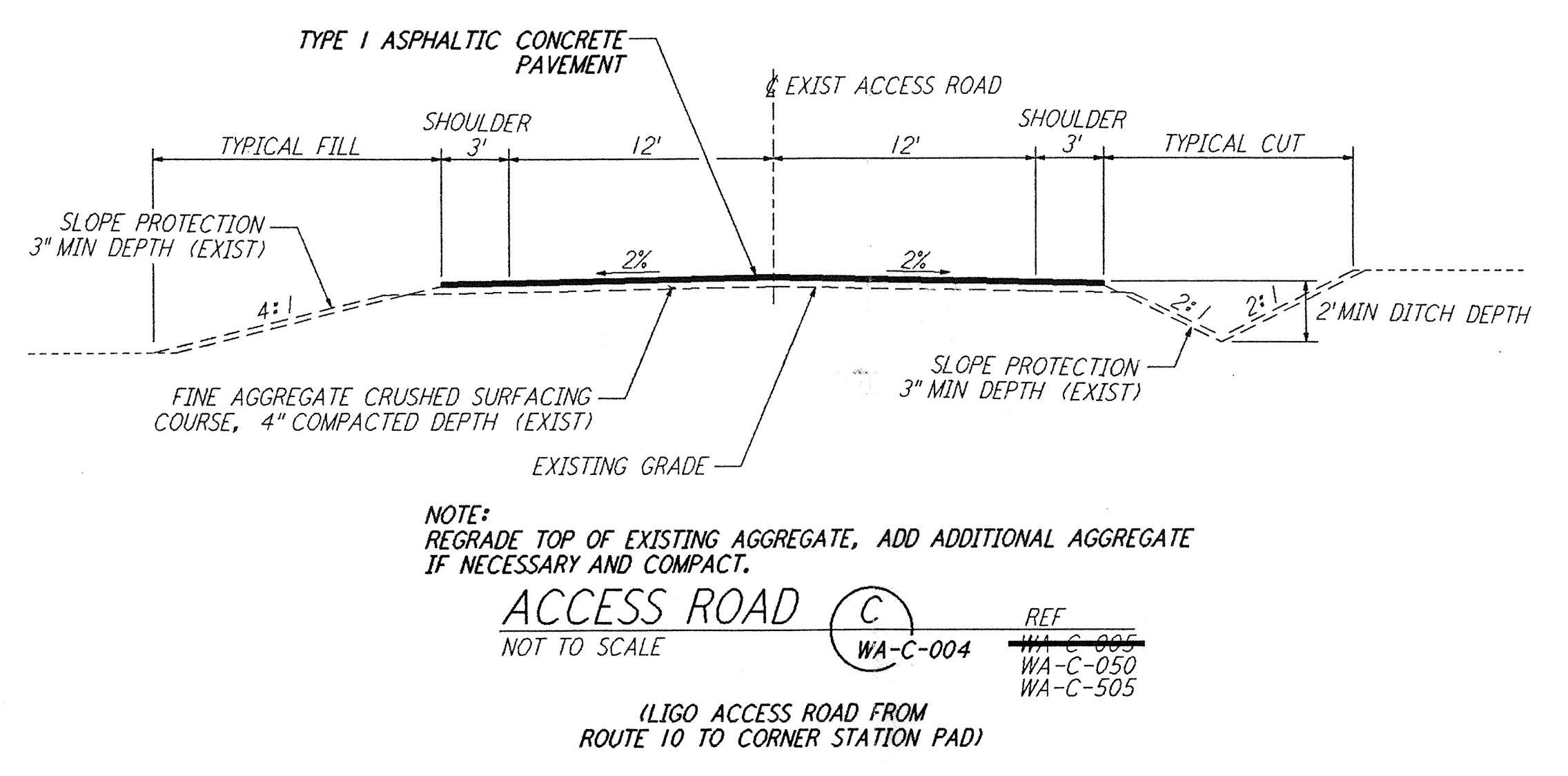
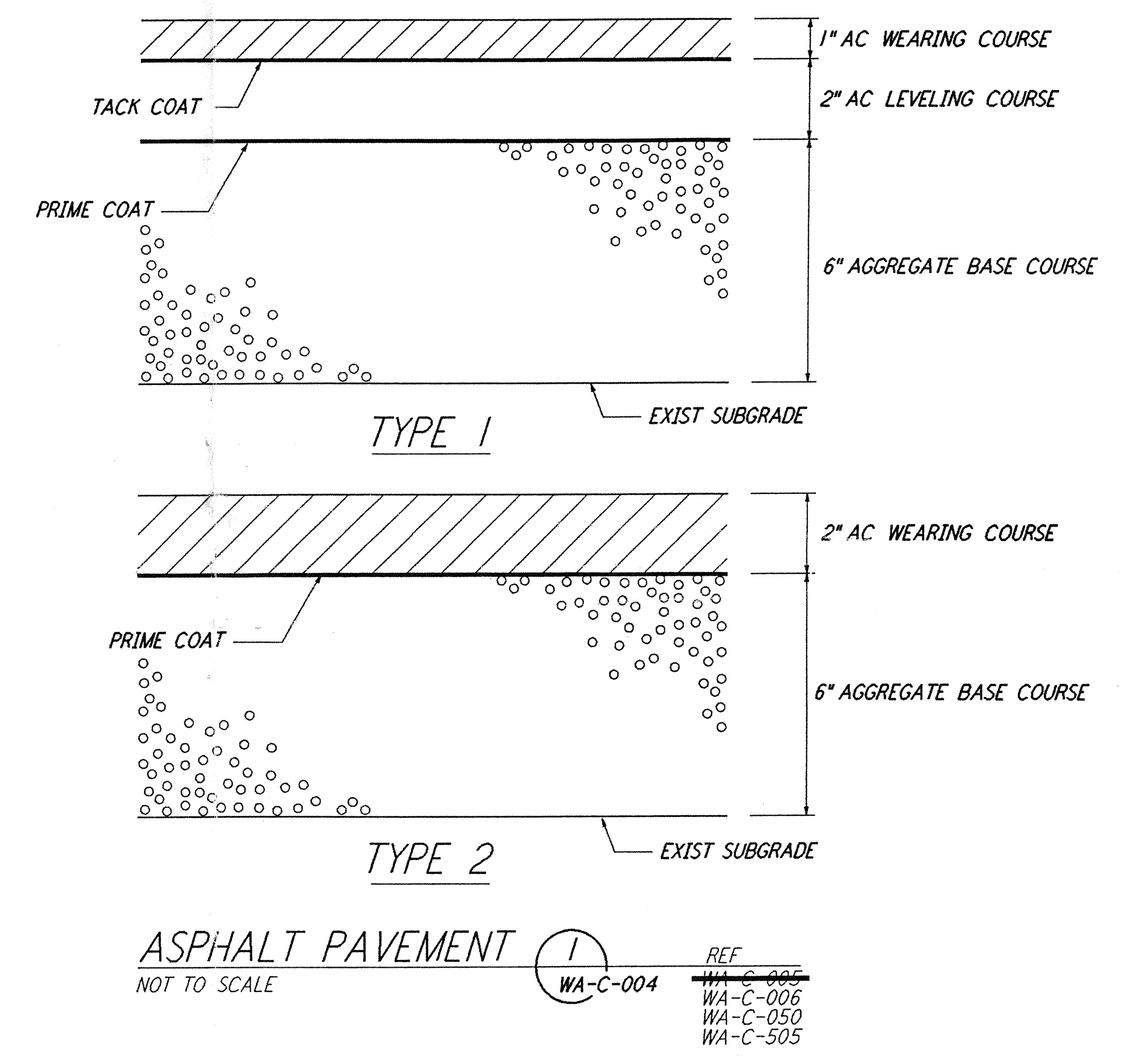
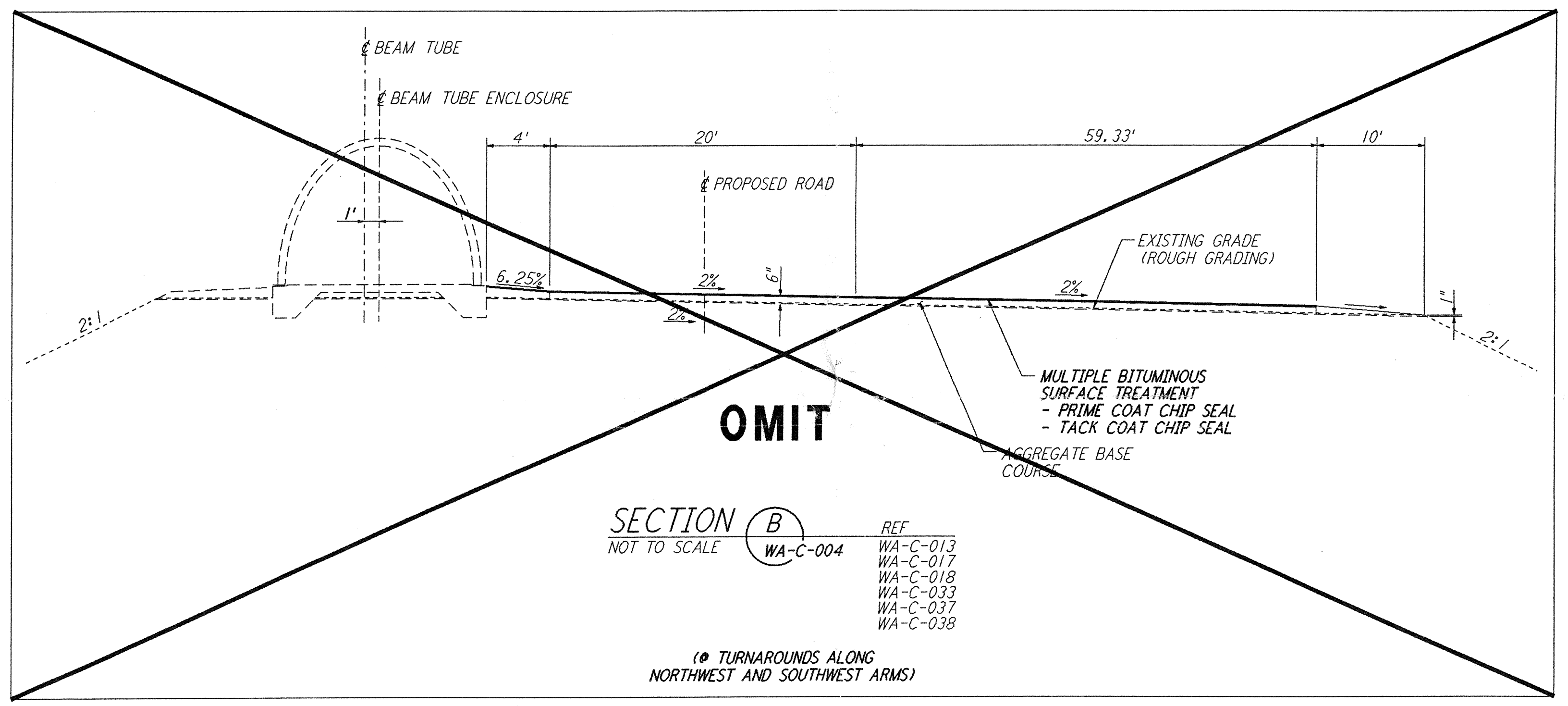
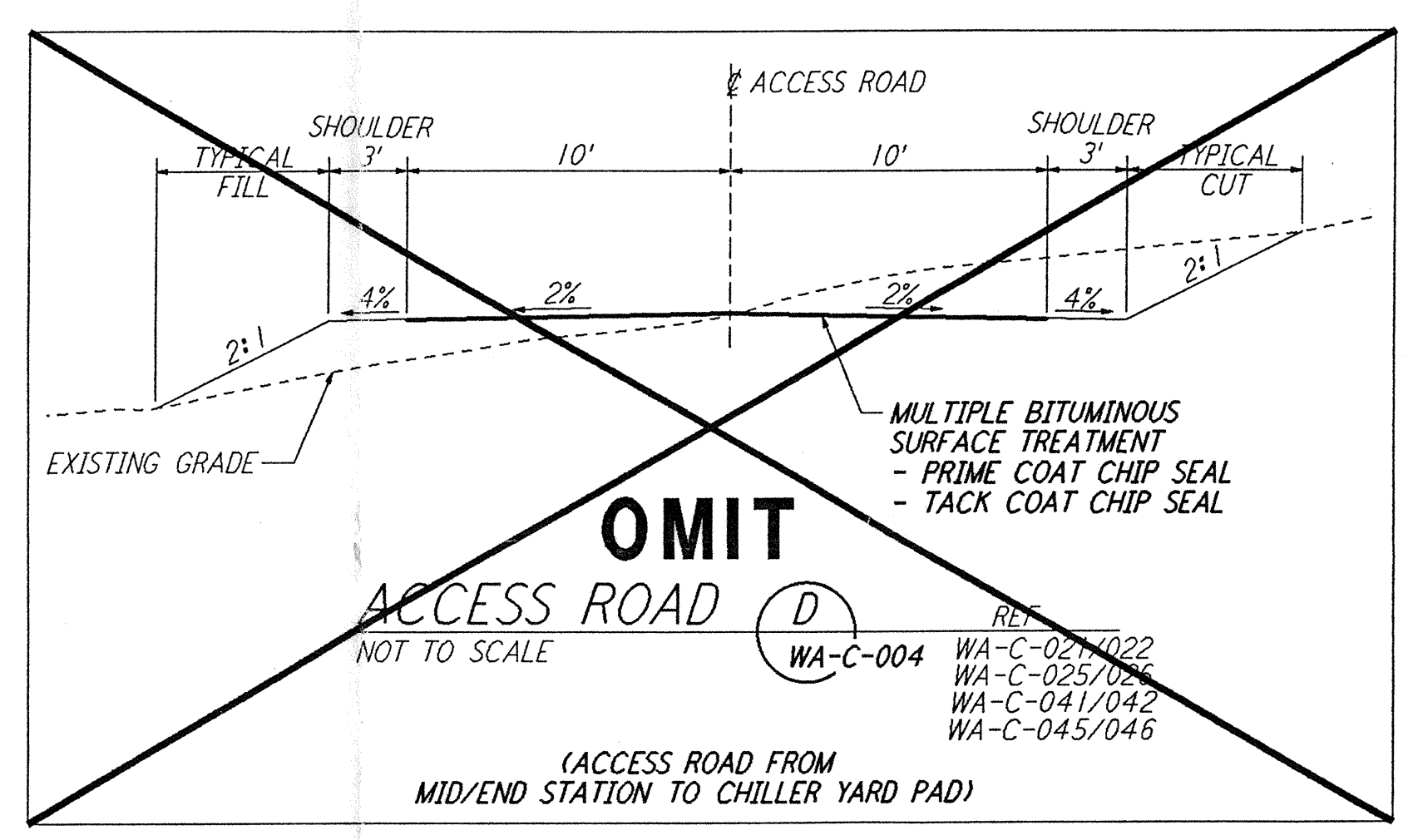
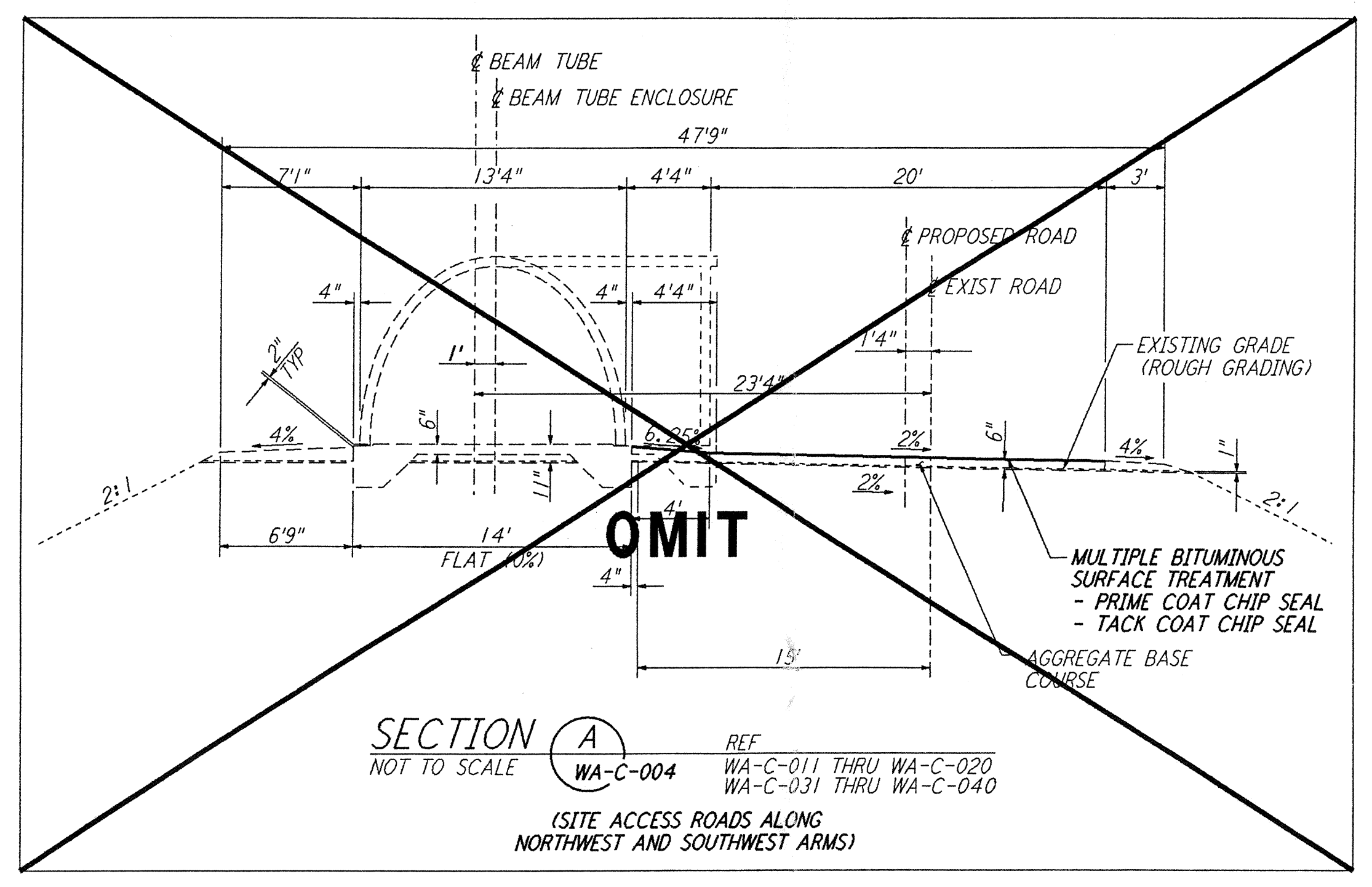

This document and the design it covers are the property of PARSONS. They are loaned only with the borrower's expressed written agreement that they will not be reproduced, copied, loaned, exhibited, or used in any other way, except by written consent from PARSONS to the borrower.

| NO. | DATE | BY | CHKD | ENGR | PROJ | DESCRIPTION |
|-----|----------|-----|------|------|------|---------------------------|
| B | 4/19/96 | WRB | MM | CP | TDW | FINAL DESIGN REVIEW & BID |
| A | 10/31/95 | WRB | | | | PRELIMINARY DESIGN REVIEW |

| | |
|----------|-----|
| DRAWN | WRB |
| CHECKED | |
| ENGINEER | |
| PROJ | |

PARSONS
 100 WEST WALNUT STREET
 PASADENA, CALIFORNIA

LIGO
 CALIFORNIA INSTITUTE OF TECHNOLOGY
 MASSACHUSETTS INSTITUTE OF TECHNOLOGY

LASER INTERFEROMETER
 GRAVITATIONAL-WAVE OBSERVATORY
 SITE NO. 1 - HANFORD, WASHINGTON

| | | | |
|------------------------------------|-------|-----------------|----------------|
| TITLE | SCALE | CONTRACT NUMBER | PROJECT NUMBER |
| CIVIL TYPICAL SECTIONS AND DETAILS | NONE | PP150969 | 8094 |
| SHEET NUMBER | | REVISIONS | |
| WA - C - 004 | | | |