

29

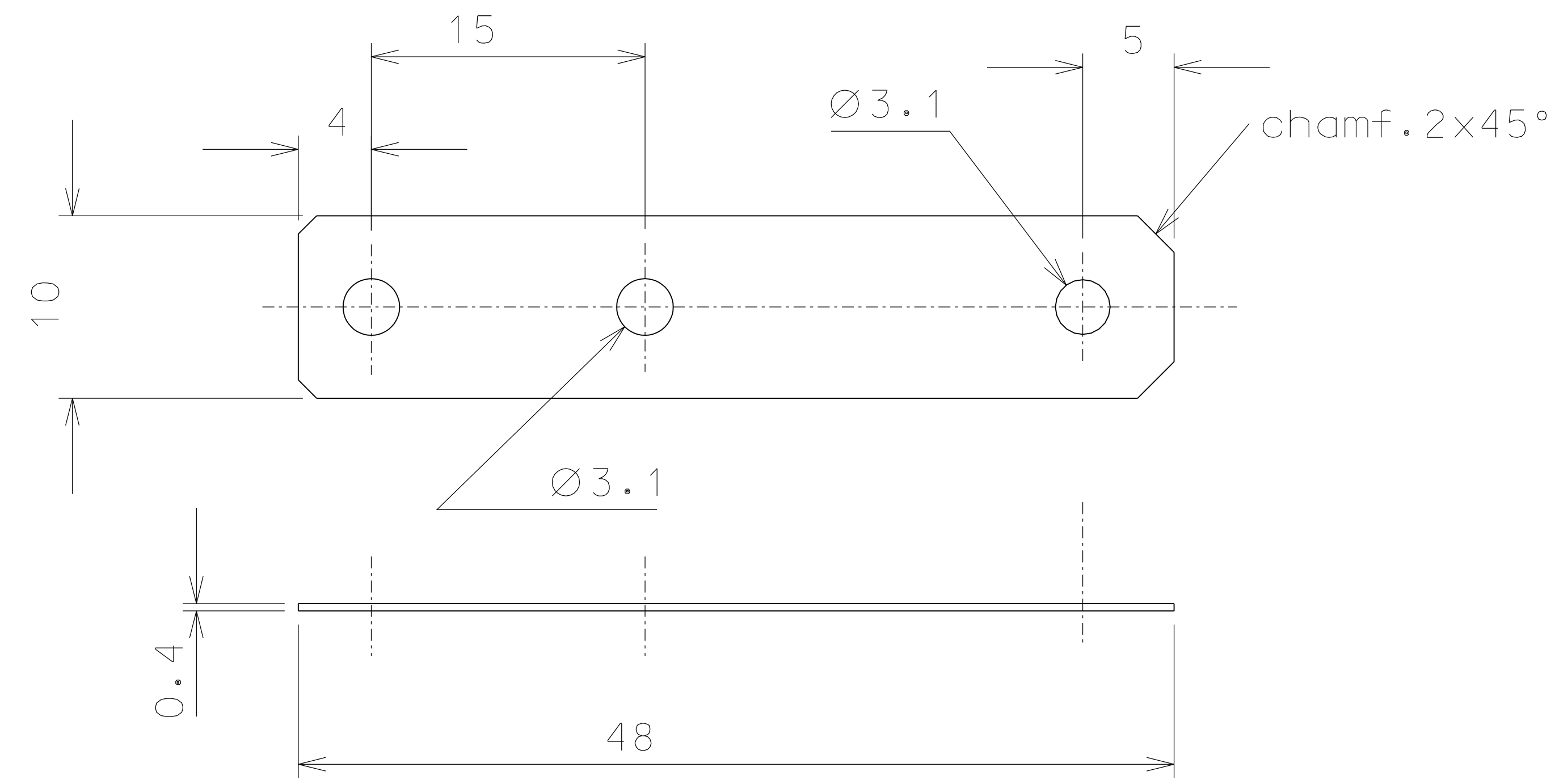

29.1

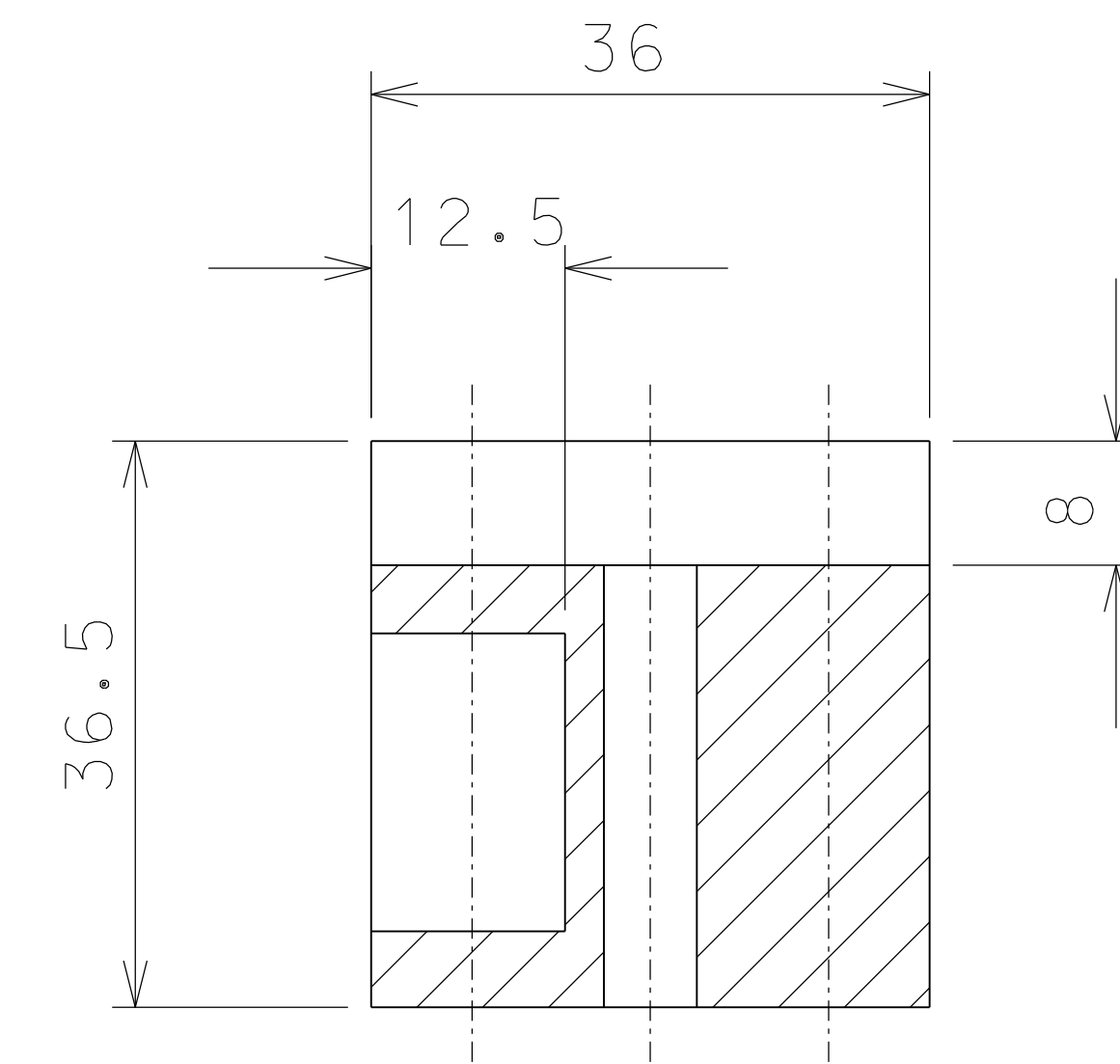

28

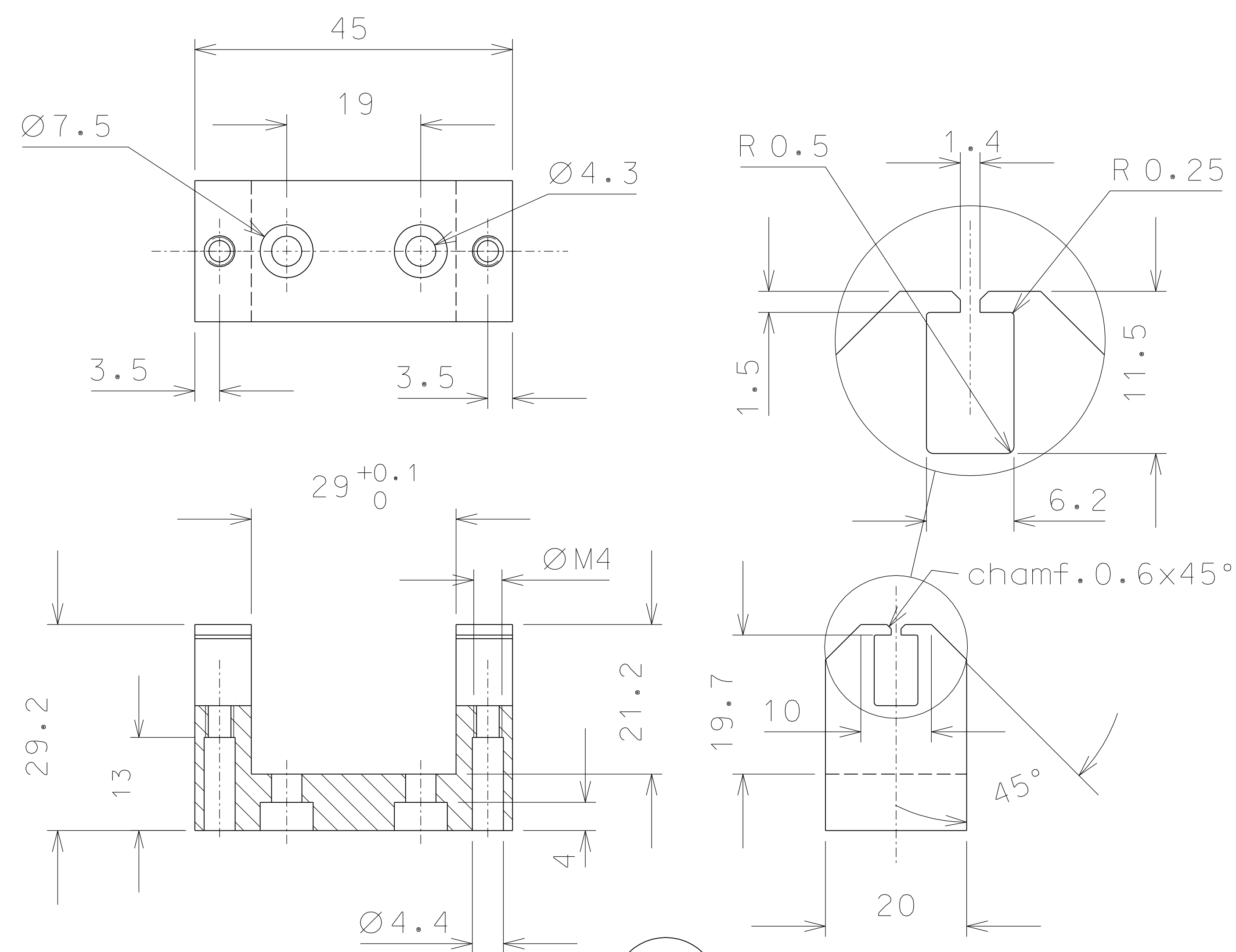
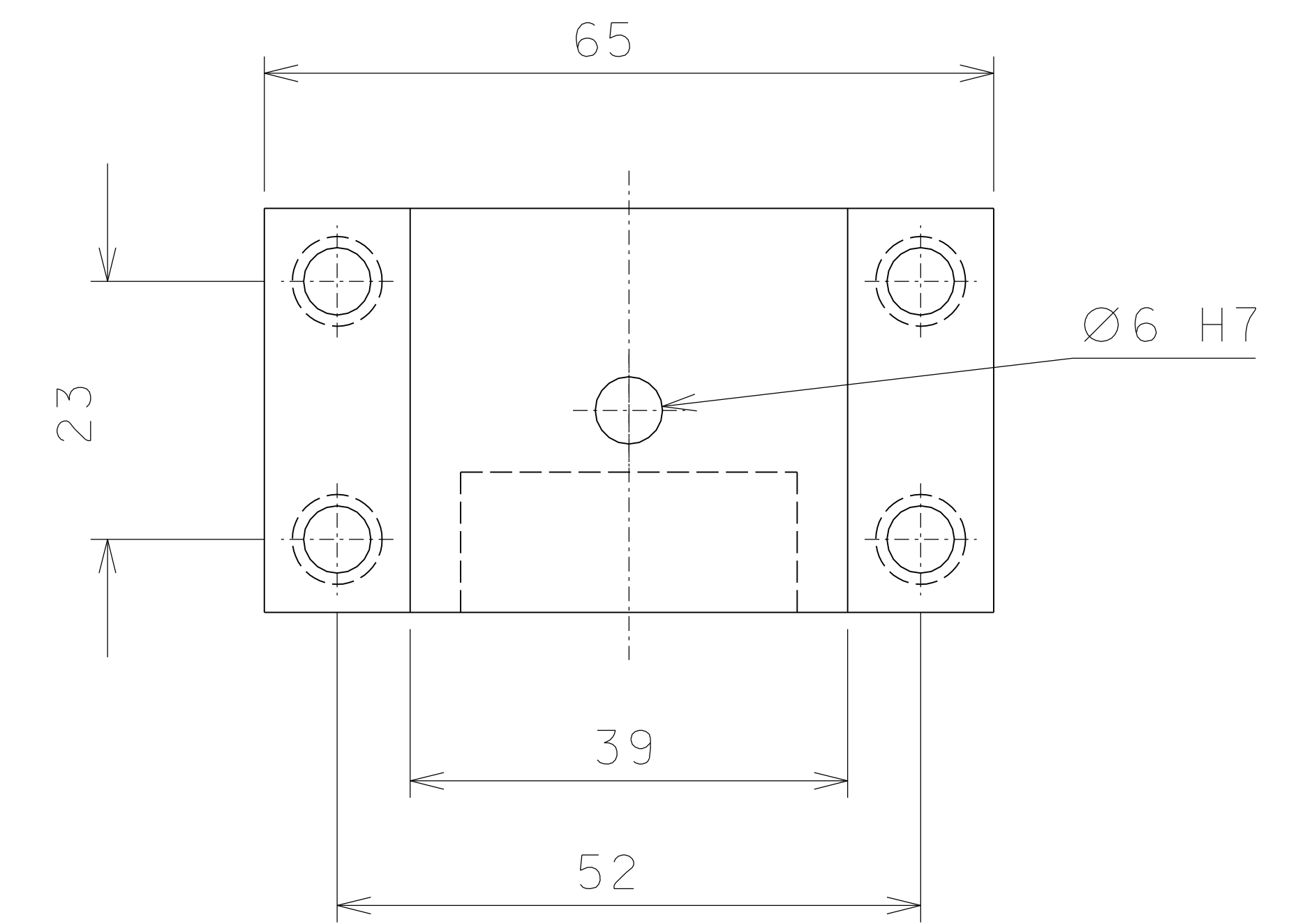
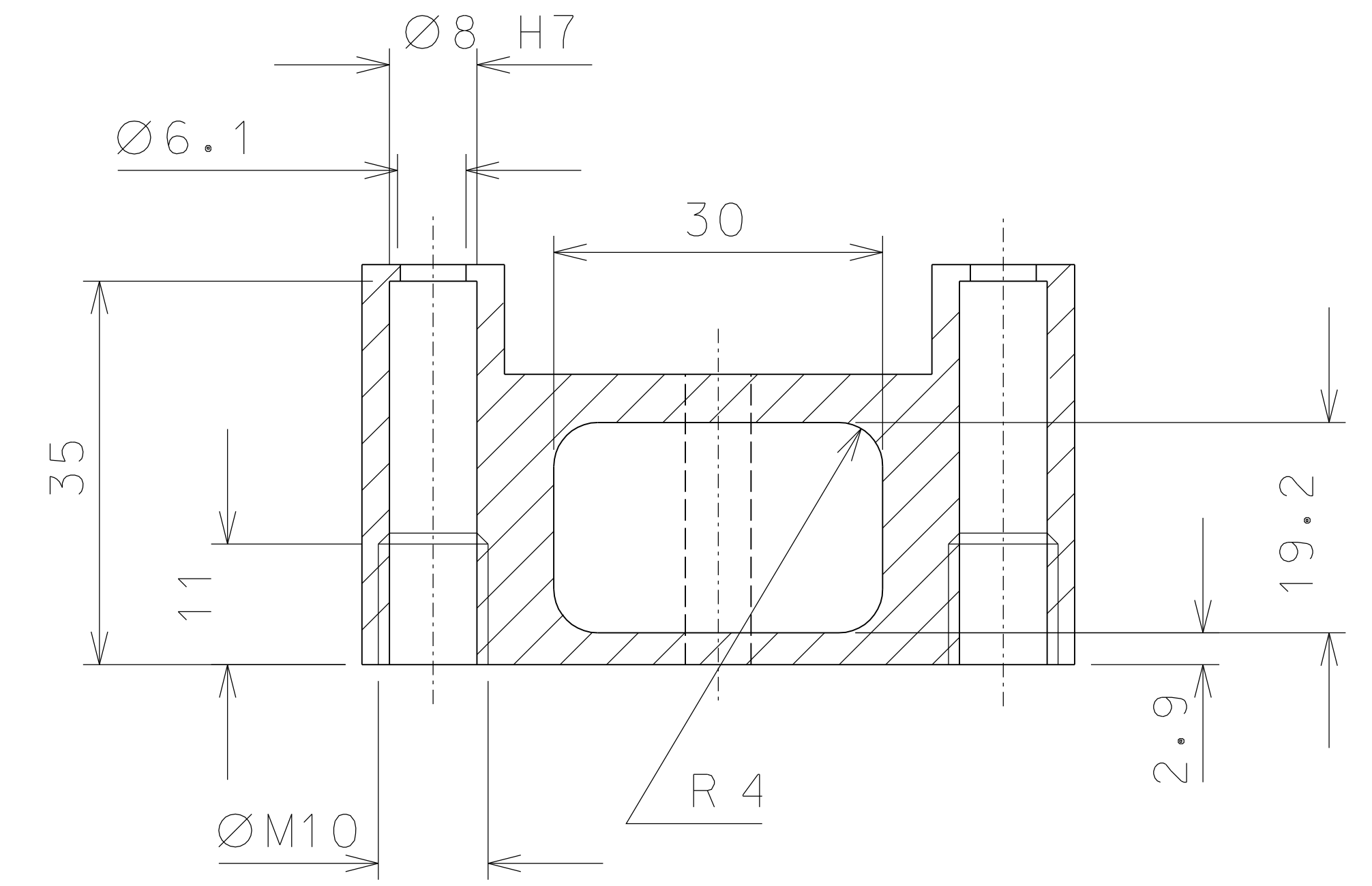

33

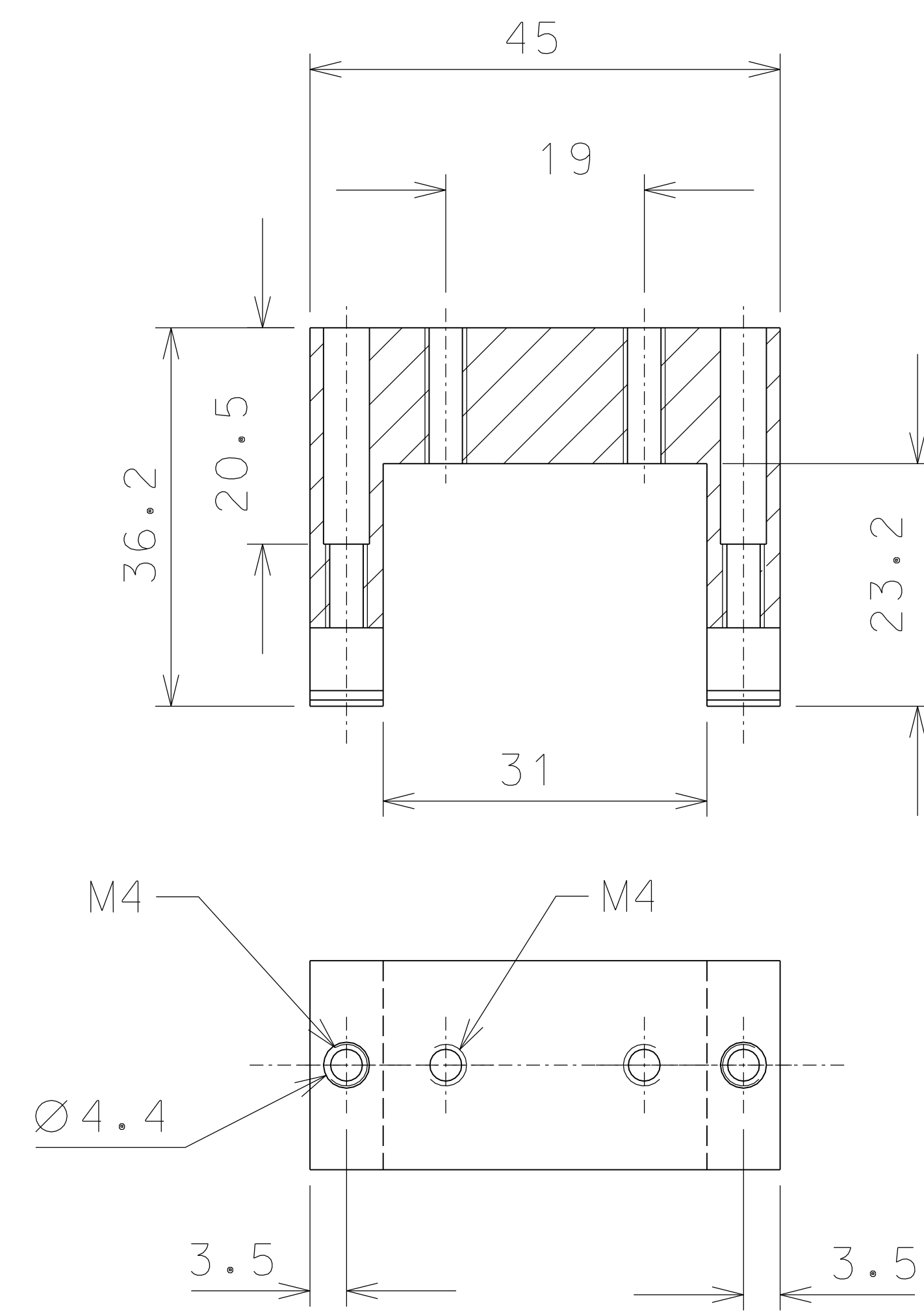

32

| ref. | pieces | mat. and treatments | scale | ref. | pieces | mat. and treatments | scale |
|------|--------|---------------------|-------|------|--------|---------------------|-------|
| 33 | 1 | AISI 316 | 1/1 | | | | |
| 32 | 1 | AISI 316 | 1/1 | | | | |
| 29.1 | 1 | carbon steel | 2/1 | | | | |
| 29 | 1 | AISI 304 | 1/1 | | | | |
| 28 | 1 | bronze B14 | 1/1 | | | | |

| General machining tolerances UNI 5307-63 | | | | | | | | |
|--|-------|--------|----------|-------------------------------------|------------|-------------|-------------|--------|
| Dimensions | < 6 | > 6-30 | > 30-120 | > 120-315 | > 315-1000 | > 1000-2000 | > 2000-4000 | > 4000 |
| linear Toll. | ± 0.1 | ± 0.2 | ± 0.3 | ± 0.5 | ± 0.8 | ± 1.2 | ± 2 | ± 3 |
| angular Toll. | ± 1 | ± 30' | ± 20' | ± 10' referred to the shortest side | | | | |

| | | | |
|--------------|----------------------|-------------|-----|
| designed for | R.De Salvo | | |
| draw. by | G. Gennaro-PROMECC | | |
| date | 9-04-08 | scale | 1/1 |
| title | TILTMETER DETAILS | | |
| ref. | 1001-1002 | detail from | A 2 |