

REV.	DATE	DCN #	DRAWING TREE #
A	12 AUG 2008	E080415-00-D	

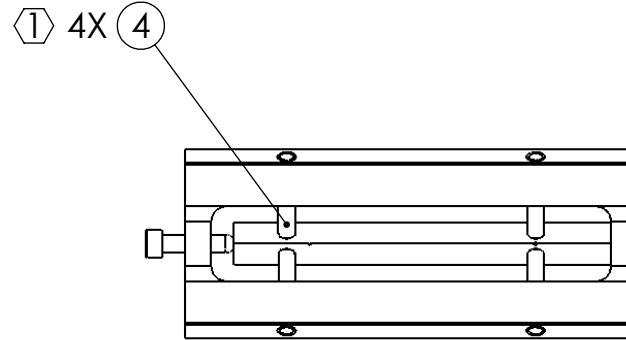
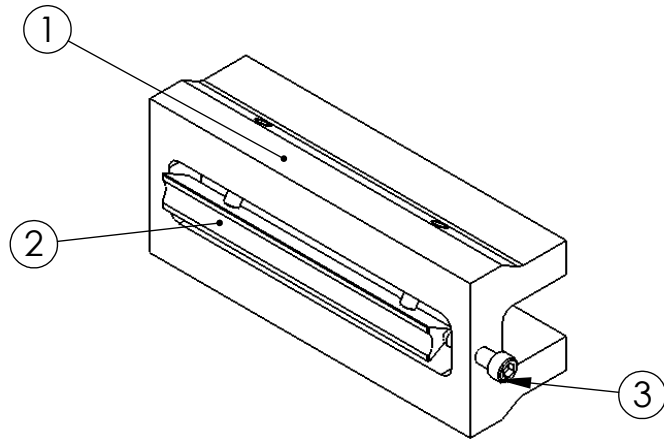

ITEM NO.	REQ	SPARE	TOTAL	PART NUMBER	DESCRIPTION	MATERIAL
4	4	1	5	-	PIN, DOWEL, \varnothing 2mm X 12mm LG $\text{\textcircled{1}}$	300 SSTL
3	1	1	2	D080468	SHCS, ROUNDED END	300 SSTL
2	1	0	1	D070033	CP WIRE BREAK-OFF PRISM	316 SSTL
1	1	0	1	D080411	PRISM HOLDER	6061-T6 AL

NOTES: (UNLESS OTHERWISE SPECIFIED)

$\text{\textcircled{1}}$ AFTER CLEANING PER LIGO-E960022, PRESS FIT DOWEL PINS INTO HOLES, FLUSH WITH PRISM HOLDER SURFACE.

DIMENSIONS ARE IN INCHES

TOLERANCES:

.XX \pm 0.01

.XXX \pm 0.005

ANGULAR \pm 0.5 °

MATERIAL

--

FINISH

-- μ inch

	NAME	DATE
DRAWN	M. MEYER	30 JUL 2008
CHECKED	D. BRIDGES	11 AUG 2008
APPROVED		



SYSTEM ADVANCED LIGO

SUB-SYSTEM SUS

NEXT ASSY D080467

PART NAME CP PRISM HOLDER

SIZE DWG. NO. D080407

REV. A

SCALE: 1:1 PROJECTION: $\text{\textcircled{1}}$ SHEET 1 OF 1