

REV.	DATE	DCN #	DRAWING TREE #
A	4 AUG 2008	E080419-00-D	

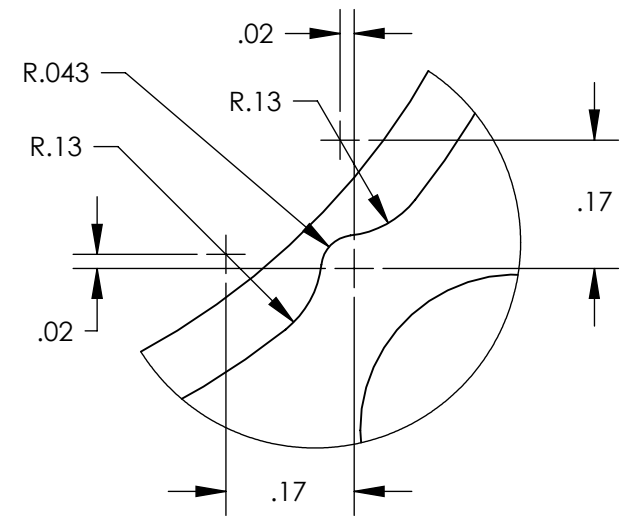

DETAIL A
SCALE 4 : 1
(x2)

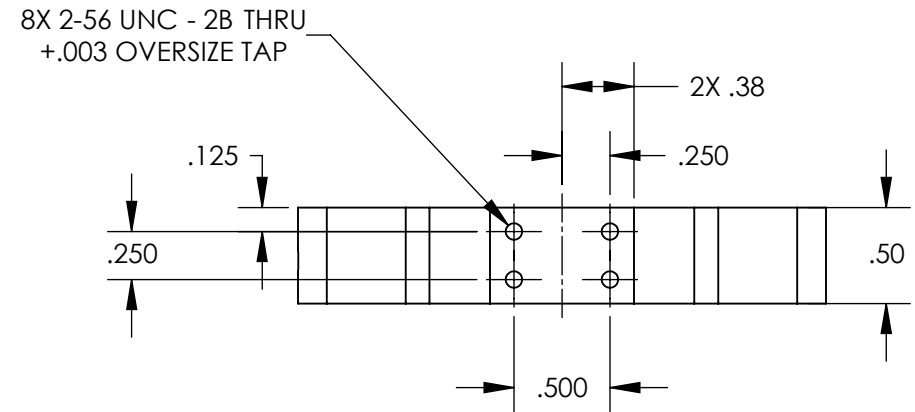
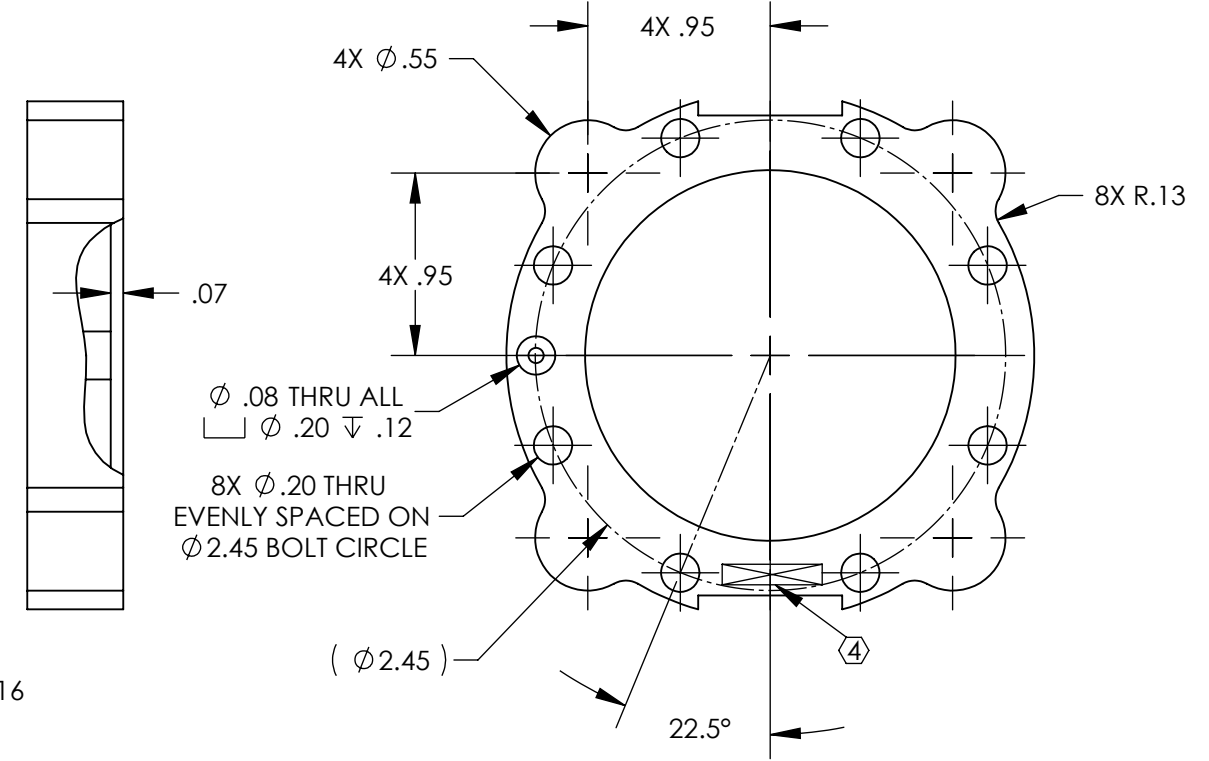
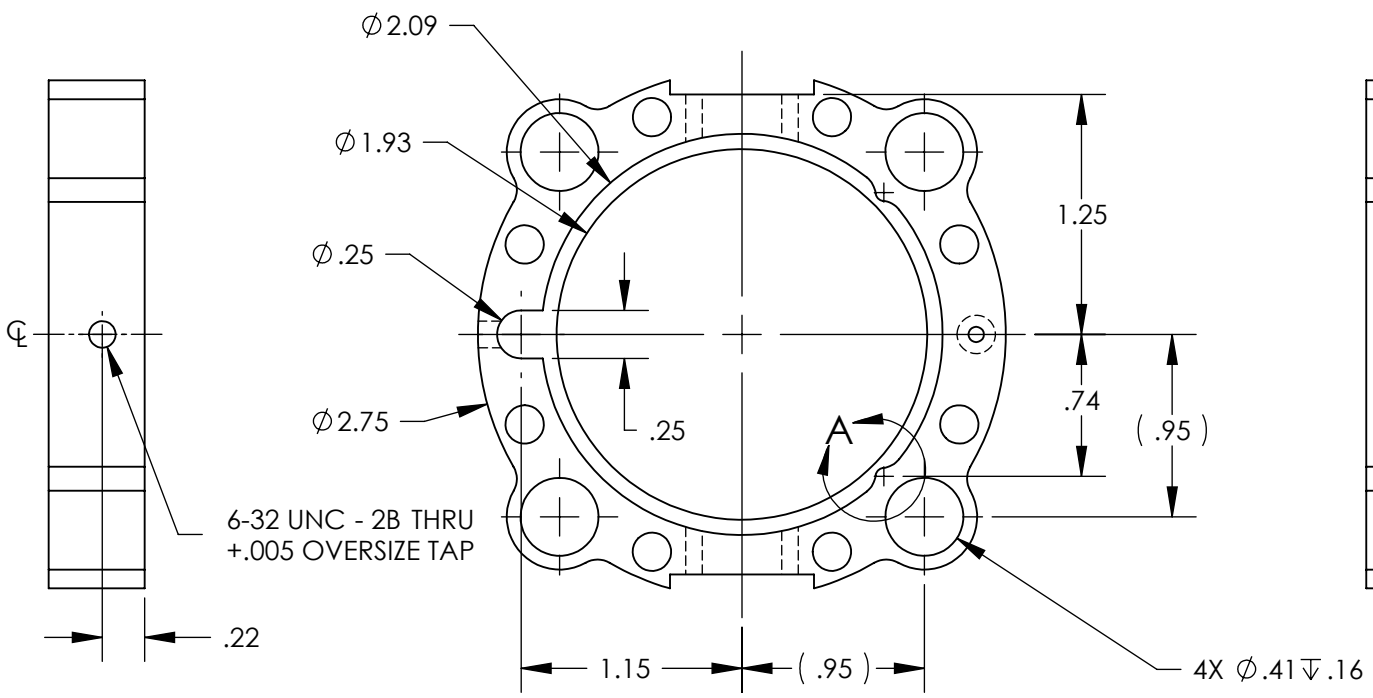
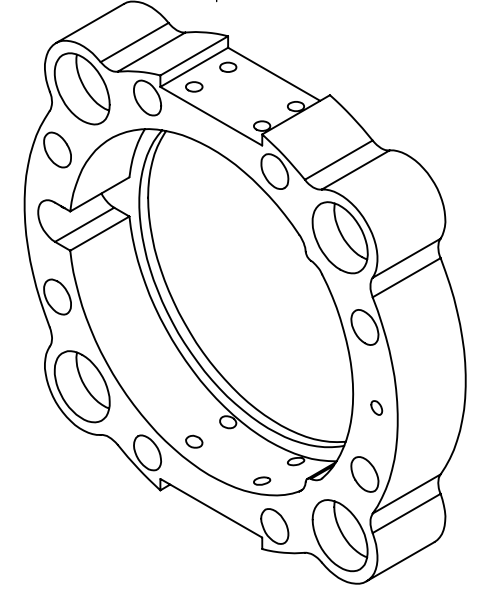

PARTS LIST															
NOTES: (UNLESS OTHERWISE SPECIFIED) 1. REMOVE ALL SHARP EDGES, R.02 MIN. 2. DO NOT SCALE FROM DRAWING. 3. ALL MACHINING FLUIDS SHALL BE WATER SOLUBLE AND FREE OF SULFUR, CHLORINE AND SILICONE, SUCH AS CINCINNATI MILACRON'S CIMTECH 410 (STAINLESS STEEL) ④ SCRIBE, ENGRAVE OR STAMP DRAWING PART NUMBER ON NOTED SURFACE OF PART AND A THREE DIGIT SERIAL NUMBER. SERIAL NUMBERS START AT 001 FOR THE FIRST PART AND PROCEED CONSECUTIVELY. USE .07" HIGH CHARACTERS. EXAMPLE: D020188-001. A VIBRATORY TOOL MAY BE USED.		DIMENSIONS ARE IN INCHES TOLERANCES: .XX ± 0.01 .XXX ± 0.005 ANGULAR ± 0.5°													
MATERIAL 6061-T6 AL		CALIFORNIA INSTITUTE OF TECHNOLOGY MASSACHUSETTS INSTITUTE OF TECHNOLOGY IGR, GLASGOW UNIVERSITY GEO 600 GROUP													
FINISH 63 μ inch		SYSTEM ADVANCED LIGO													
<table border="1"> <thead> <tr> <th></th> <th>NAME</th> <th>DATE</th> </tr> </thead> <tbody> <tr> <td>DRAWN</td> <td>M. MEYER</td> <td>07 JAN 2008</td> </tr> <tr> <td>CHECKED</td> <td>J. ROMIE</td> <td>4 AUG 2008</td> </tr> <tr> <td>APPROVED</td> <td></td> <td></td> </tr> </tbody> </table>			NAME	DATE	DRAWN	M. MEYER	07 JAN 2008	CHECKED	J. ROMIE	4 AUG 2008	APPROVED			SUB-SYSTEM SUS	
	NAME	DATE													
DRAWN	M. MEYER	07 JAN 2008													
CHECKED	J. ROMIE	4 AUG 2008													
APPROVED															
		NEXT ASSY TT MIRROR ASSEMBLY													
		PART NAME 2" MIRROR HOLDER													
		SIZE B	DWG. NO. D080069												
		SCALE: 1:1	PROJECTION:												
		SHEET 1 OF 1													