

REV.	DATE	DCN #	DRAWING TREE #
A	4 AUG 2008	E080419-00-D	

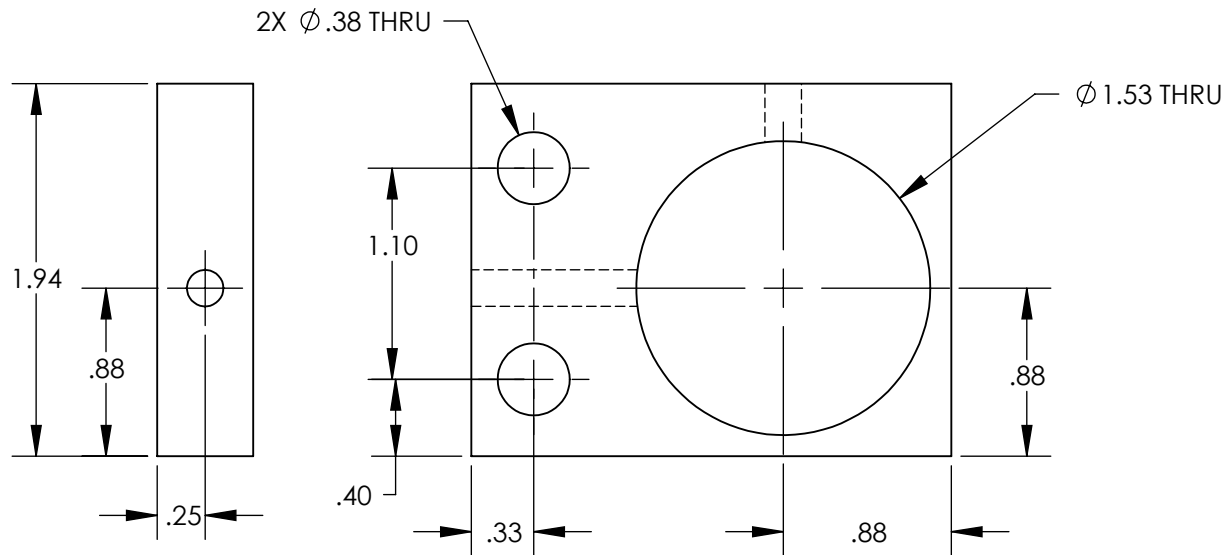
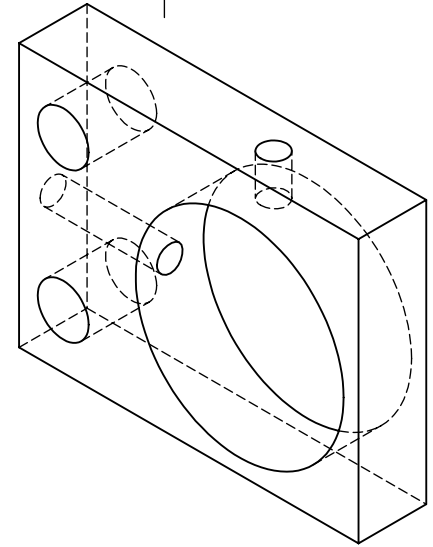
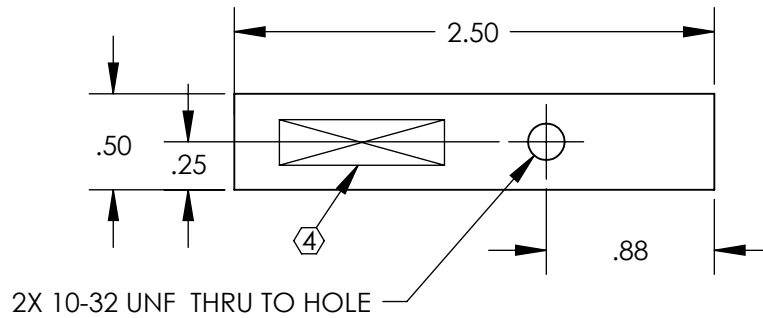

NOTES: (UNLESS OTHERWISE SPECIFIED)

1. REMOVE ALL SHARP EDGES, R.02 MIN.
2. DO NOT SCALE FROM DRAWING.
3. ALL MACHINING FLUIDS SHALL BE WATER SOLUBLE AND FREE OF SULFUR, CHLORINE AND SILICONE, SUCH AS CINCINNATI MILACRON'S CIMTECH 410 (STAINLESS STEEL)
- ④ SCRIBE, ENGRAVE OR STAMP DRAWING PART NUMBER ON NOTED SURFACE OF PART AND THEN A THREE DIGIT SERIAL NUMBER. SERIAL NUMBERS START AT 001 FOR THE FIRST PART AND PROCEED CONSECUTIVELY. USE .07" HIGH CHARACTERS. EXAMPLE: D020188-001. A VIBRATORY TOOL MAY BE USED.

DIMENSIONS ARE IN INCHES

TOLERANCES:
 .XX ± 0.01
 .XXX ± 0.005

ANGULAR ± 0.5 °

MATERIAL
 6061-T6 AL

FINISH
 63

	NAME	DATE
DRAWN	M. MEYER	23 JAN 2008
CHECKED	D. BRIDGES	4 AUG 2008
APPROVED		

LIGO CALIFORNIA INSTITUTE OF TECHNOLOGY
 MASSACHUSETTS INSTITUTE OF TECHNOLOGY
 IGR, GLASGOW UNIVERSITY GEO 600 GROUP

SYSTEM ADVANCED LIGO

SUB-SYSTEM SUS

NEXT ASSY D080057

PART NAME ECD MOUNT REAR

SIZE **DWG. NO.** D080068 **REV.** A

SCALE: 1:1 **PROJECTION:** **SHEET 1 OF 1**