

REV.	DATE	DCN #	DRAWING TREE #
A	4 AUG 2008	D080419-00-D	

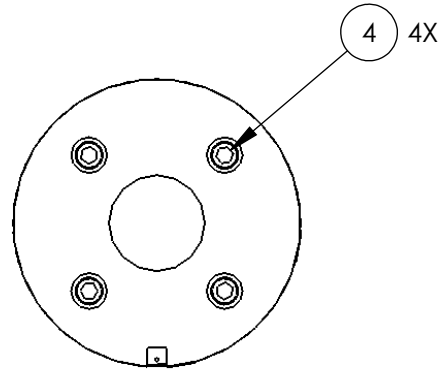
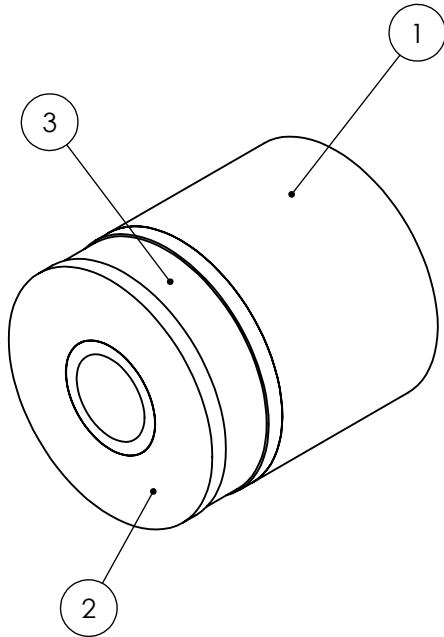

ITEM NO.	REQ	SPARE	TOTAL	PART NUMBER	DESCRIPTION	MATERIAL
4	4	1	5	-	SCREW, SOCKET HEAD CAP, #2-56 X 0.75 LG	300 SSSL
3	A/R	-	A/R	-	32AWG MAGNET WIRE	QUAD ML
2	1	1	2	D080074	ECD COILFORMER PLATE	COPPER
1	1	1	2	D080073	ECD COILFORMER	TEFLON

NOTES: (UNLESS OTHERWISE SPECIFIED)

DIMENSIONS ARE IN INCHES

TOLERANCES:

.XX ± 0.01

.XXX ± 0.005

ANGULAR ± 0.5 °

MATERIAL

--

FINISH

--

	NAME	DATE
DRAWN	M. MEYER	30 MAY 2008
CHECKED	D. BRIDGES	4 AUG 2008
APPROVED		



SYSTEM ADVANCED LIGO

SUB-SYSTEM SUS

NEXT ASSY D080057

PART NAME ACTIVE ECD ASSEMBLY

SIZE DWG. NO. D080059 REV. A

SCALE: 1:1 PROJECTION: SHEET 1 OF 1