

REV	DATE	DCN #	DRAWING TREE #
00	AUG07	INITIAL RELEASE - GUIDE FOR BONDING AT LASTI (R.JONES)	

WHEN BONDING, THE CENTRAL DATUM AXIS OF MASS MUST BE ALIGNED AS COINCIDENT WITH THE CENTRAL DATUM AXIS OF THE TEMPLATE (DATUM -A-)

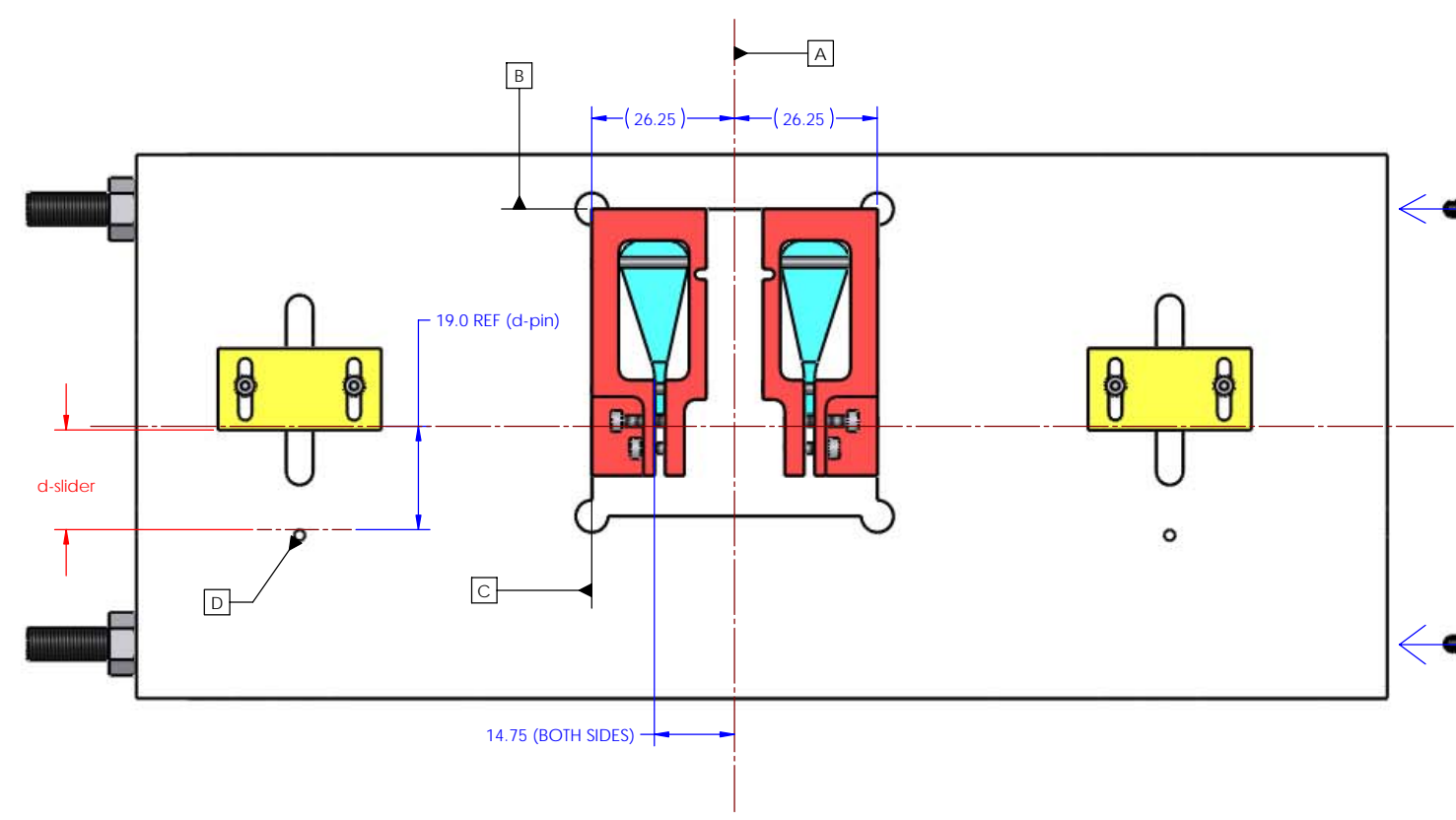

PLAN VIEW:- BONDING JIG AS IT WOULD BE VIEWED WHEN IN USE

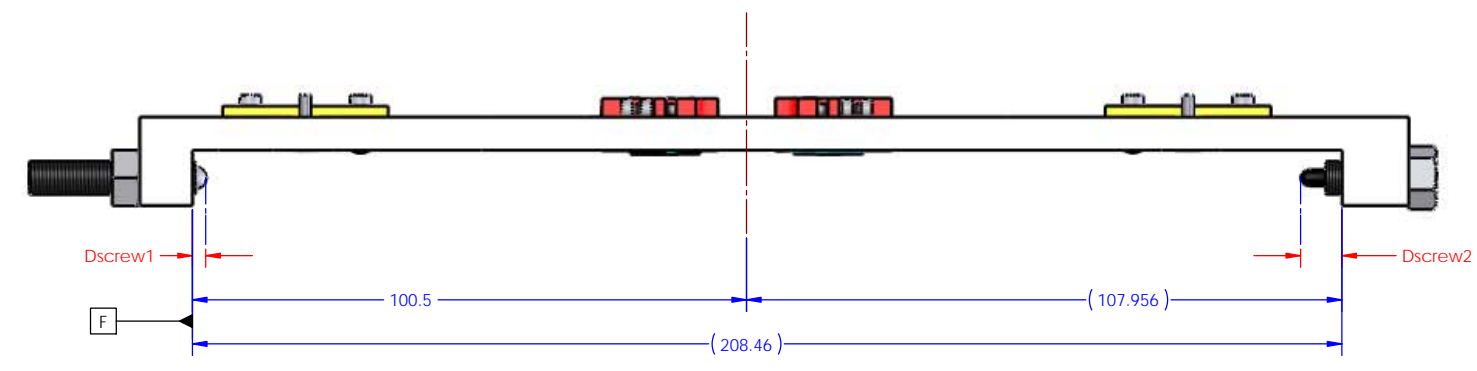

- LIST OF DATUMS ON TEMPLATE:**
- A** (IMPLIED) alignment axis of template. To be coincident with central (vertical) axis of flats on mass.
 - B** upper reference edge for ear holder
 - C** side reference edge for ear holder
 - D** measurement pin - to correct template position for a given flexure point
 - E** surface on ear parallel and opposite to bonding surface)
 - F** datum surface when setting up template to interface with mass, **F** is 100.5 mm from **A**.

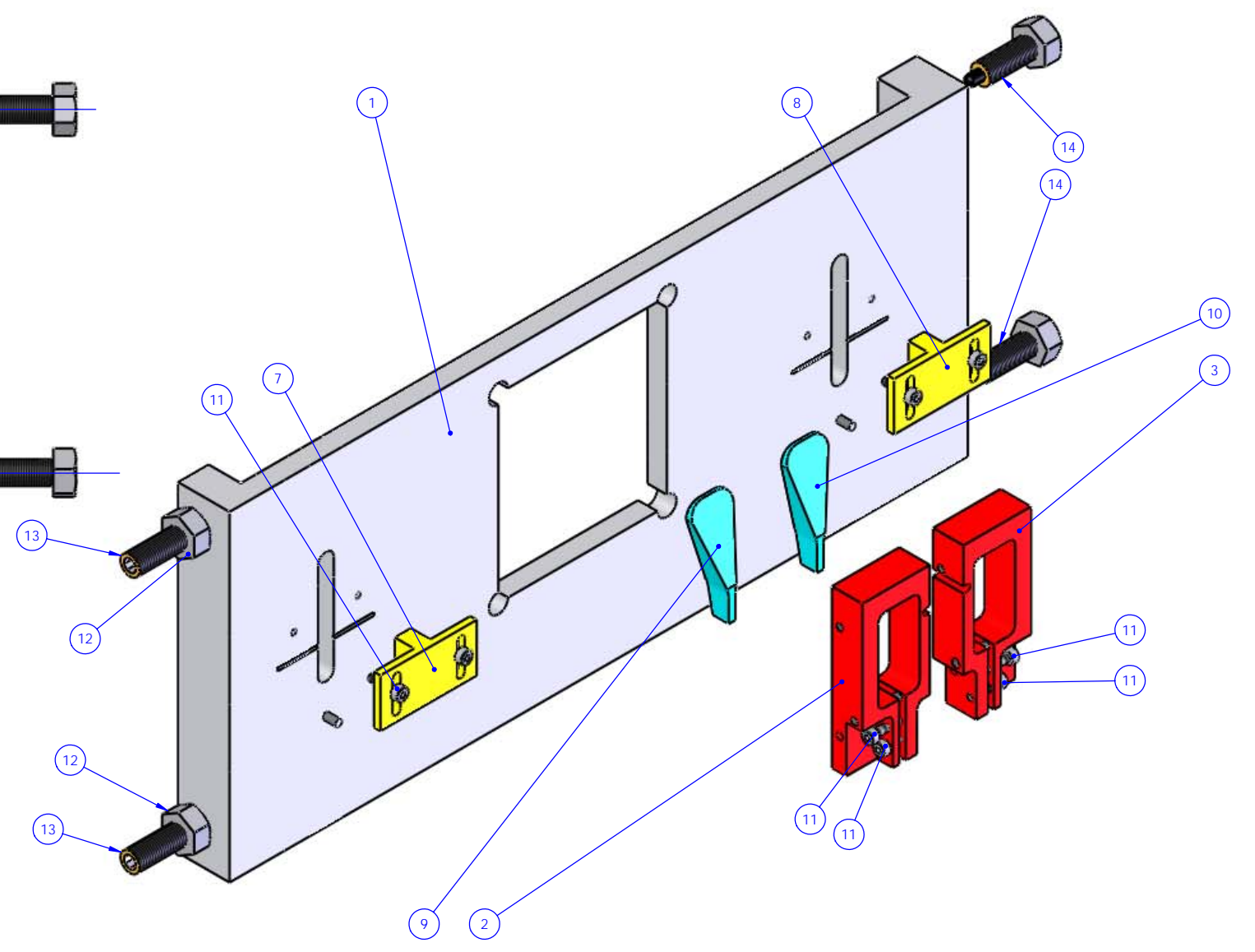

EXPLODED ISOMETRIC VIEW

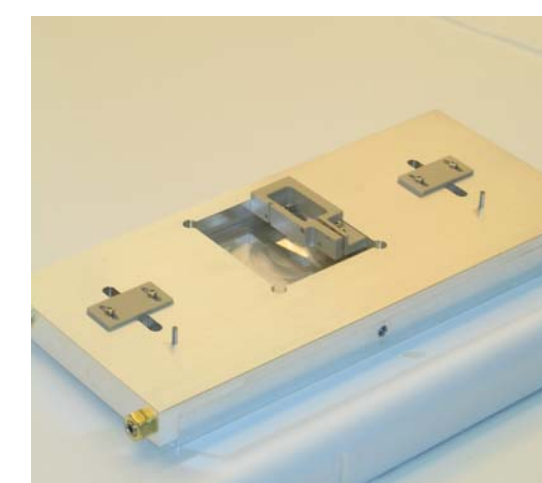

ITEM NO.	PART NUMBER	DESCRIPTION	Default/ QTY.
1	TD-1084-711-1	BASE PLATE	1
2	TD-1084-712-1	EAR HOLDER (type-A Ear)	1
3	TD-1084-712B-1	EAR HOLDER (type-B Ear)	1
4	TD-1084-715-1	steel ball bearing	1
5	TD-1084-715_1-1	steel ball bearing	1
6	TD-1084-715_2-1	steel ball bearing	1
7	T_PIECE-1		1
8	T_PIECE-1-1		1
9	D060055_Refined Ear (type A)	Refined Ear (type A)	1
10	D060056_Refined Ear (type B)	Refined Ear (type B)	1
11	SST SOCKET HEAD CAP SCREW M2 X 8 LONG		8
12	M6 SST HEX NUT -DIN 934 (OR EQUIV.)		4
13	M6 ballended setscrew		2
14	M6_spring pin end setcrew		2

PARTS LIST	
NOTES: (UNLESS OTHERWISE SPECIFIED)	
1. DO NOT SCALE FROM DRAWING.	DIMENSIONS ARE IN MILLIMETERS
2. SUPPORT DRAWINGS FOR ASSEMBLY ACTIVITY ONLY.	TOLERANCES: X .01 ANGULAR ± 0.5 °
	MATERIAL: SUS
	FINISH: ETM NP-type (GLASS MASS)
	PART NAME: EAR BONDING JIG GA
	SCALE: 1:1 PROJECTION: 1st Angle

REV	DATE	BY	CHKD	APPV	DRWG. NO.	SHEET	TOTAL
00	AUG07	D			DO70391	1	1

REV	DATE	DCM #	DRAWING TREE #
00	AUG07	INITIAL RELEASE - GUIDE FOR BONDING AT LASTI (R.JONES)	

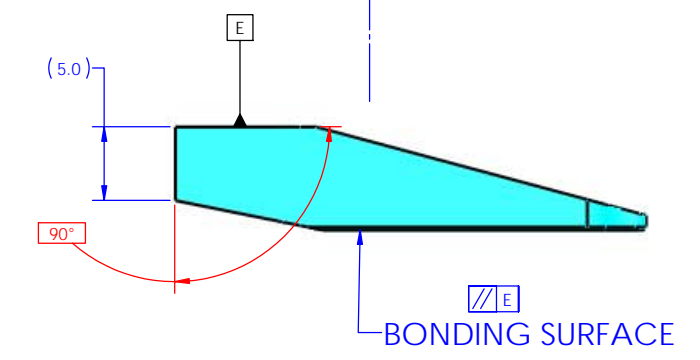
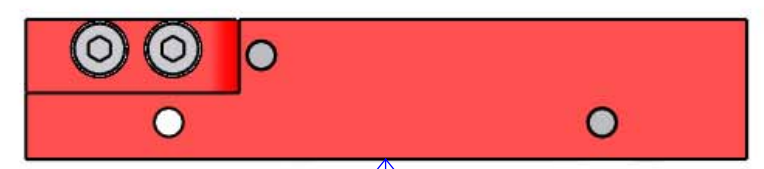
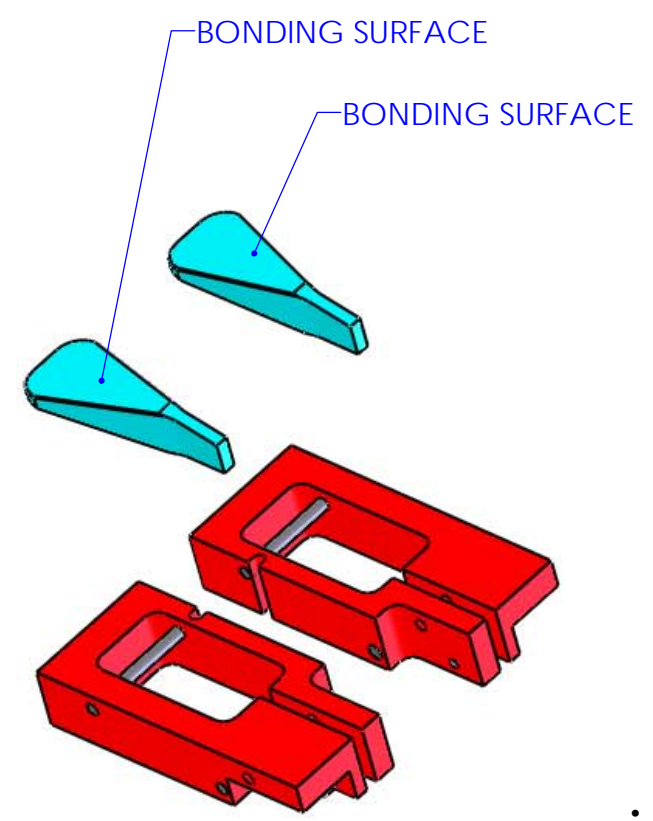
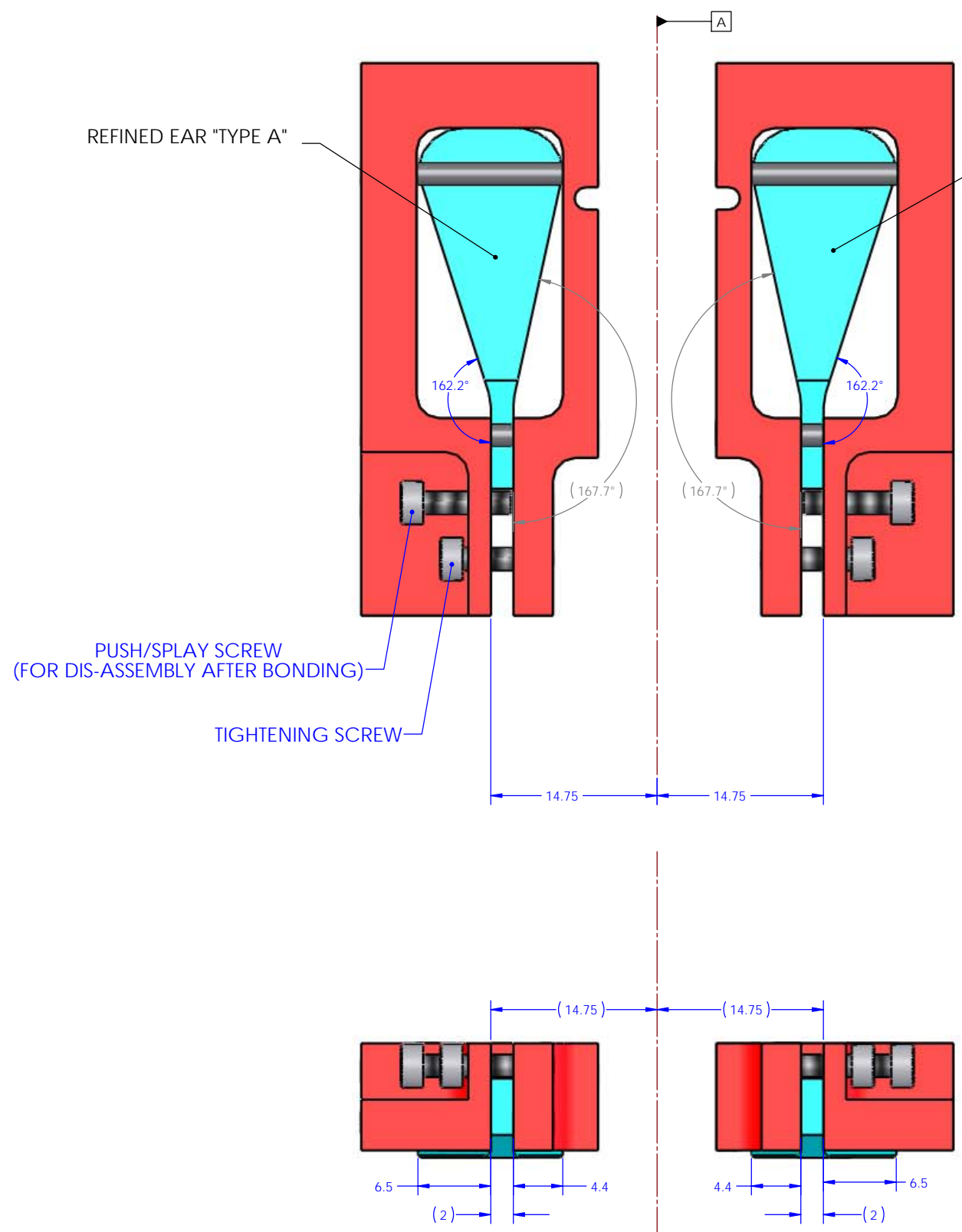

IDENTIFYING THE BONDING SURFACE:

- LOOK CLOSELY AT THE 2mm WIDE EXTENDED LENGTH (FOR WELDING)
 - IDENTIFY THE 90° CORNER
 - THE BONDING FLAT IS OPPOSITE AND PARALLEL TO -E- (above)

THE CENTRAL DATUM AXIS (DATUM -A-) ALSO HELPS IDENTIFY THE SUBTLE DIFFERENCE BETWEEN REFINED EAR "TYPE A" AND "TYPE B".
CONSIDER DATUM -A-, AS AN AXIS OF SYMMETRY: "TYPE B" IS THE MIRROR IMAGE OF "TYPE A" ABOUT THAT AXIS.

NOTES: (UNLESS OTHERWISE SPECIFIED)		PARTS LIST	
1. DO NOT SCALE FROM DRAWING.	DIMENSIONS ARE IN MILLIMETERS	CALIFORNIA INSTITUTE OF TECHNOLOGY GLASGOW UNIVERSITY GEO 400 GROUP	
2. SUPPORT DRAWINGS FOR ASSEMBLY ACTIVITY ONLY.	TOLERANCES: X ±0.1 ANGULAR ±0.5°	SYSTEM	ALIGO
		SUB-SYSTEM	SUS
		MATERIAL	---
		NEXT ASSY	ETM NP-type (GLASS MASS)
		FINISH	---
		PART NAME	EAR BONDING JIG GA
DRAWN	NAME	DATE	
CHECKED	DATE	DATE	
APPROVED	DATE	DATE	
	SCALE: 1:1	PROJECTION:	