

REV.	DATE	DCN #	DRAWING TREE #
A	12DEC06	E060275 INITIAL RELEASE	
B	6MAR 07	E070062 ADD SIDE REF MARKS	

ETCH, GRIND OR SANDBLAST  
LEGIBLE REFERENCE GROOVE  
(GROOVE WIDTH 0.25mm MIN, 0.5mm MAX.)  
ALONG  $\phi$ , AT LOCATION OF MAX PART THICKNESS,  
PARALLEL TO CYLINDRICAL AXIS (DEFINED BY DATUM A.)

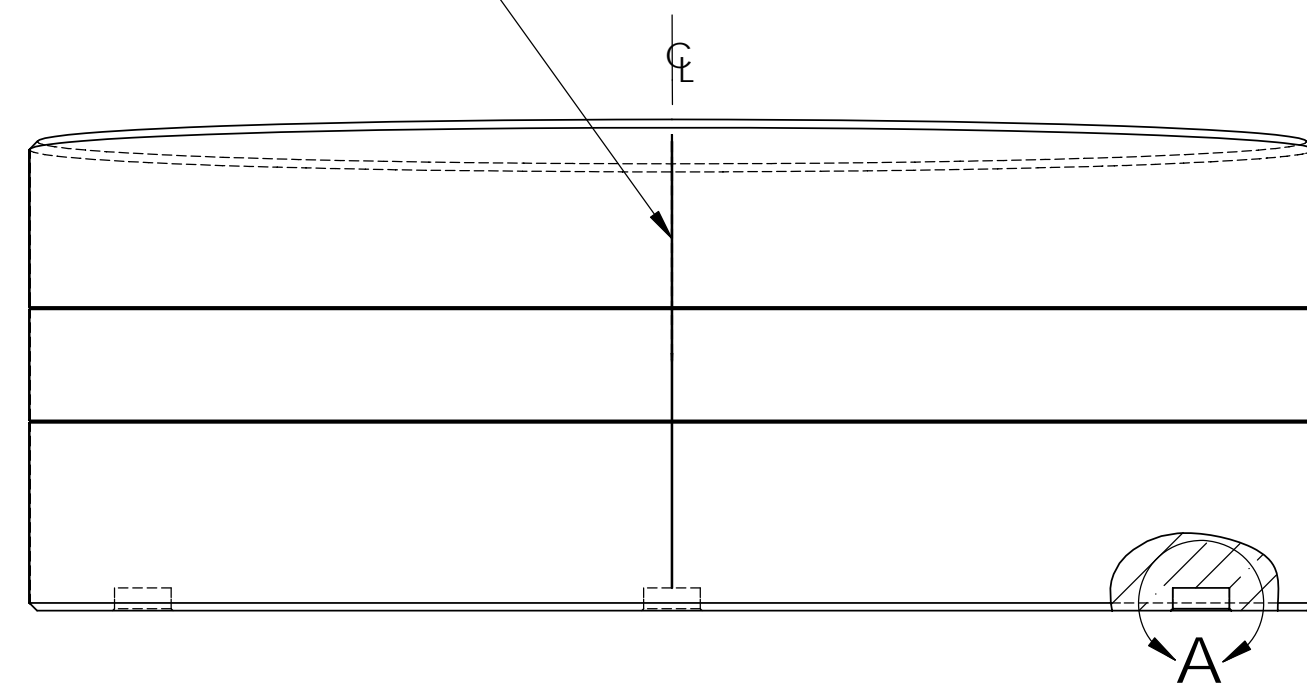

4X,  $\phi 15.0 \pm 0.25$ ,  $\nabla 6.0$   
 $\nabla \phi 16.0$  MAX x  $90^\circ$   
EQUALLY SPACED ON A  $\phi 280 \pm 2$  BOLT CIRCLE  
EDGE CHIPPING TO BE MINIMIZED

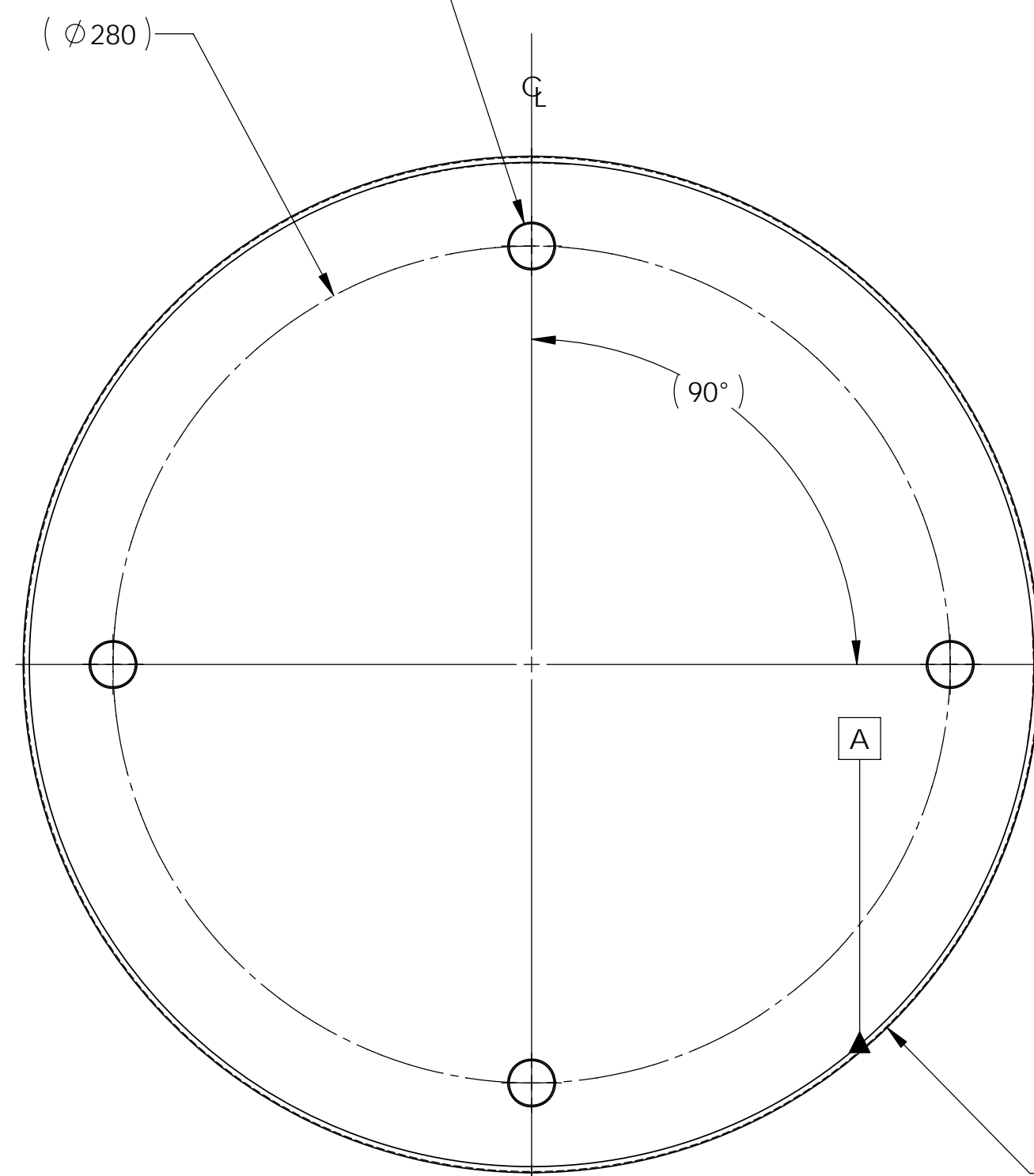

ETCH, GRIND OR SANDBLAST  
LEGIBLE REFERENCE GROOVE  
(GROOVE WIDTH 0.25mm MIN, 0.5mm MAX.)  
AT LOCATION OF MIN PART THICKNESS,  
PARALLEL TO THE CYLINDRICAL  
AXIS (DEFINED BY DATUM -A-).

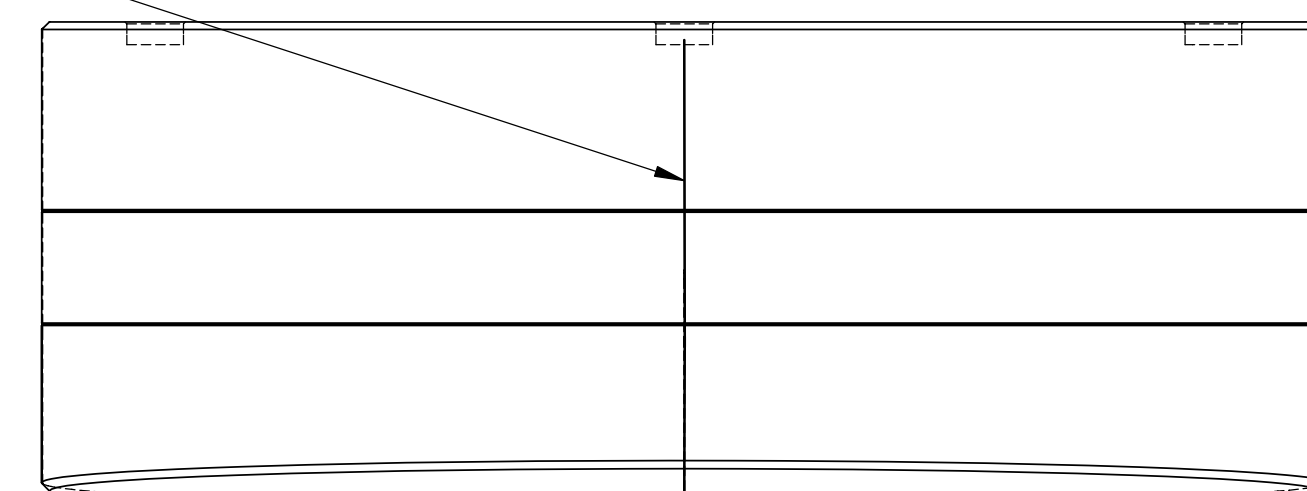

RADIUS AROUND BOTTOM  
OF RECESS, R 1mm, MAX  
GROUND FINISH ACCEPTABLE  
FOR BASE AND SIDES OF RECESS

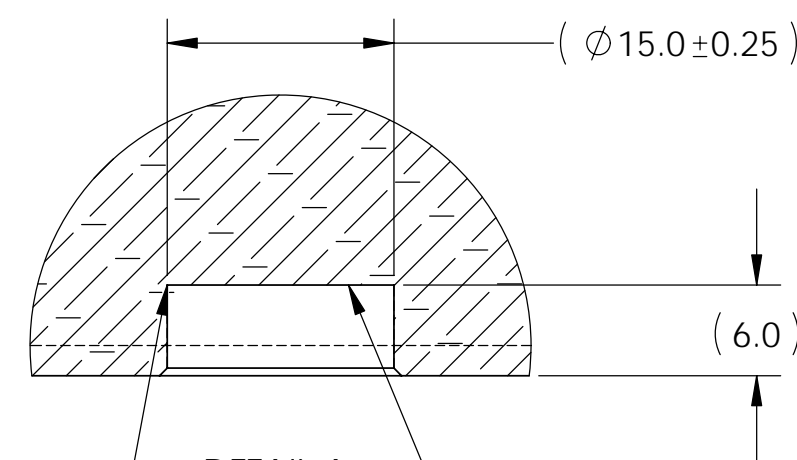

DETAIL A  
SCALE 2:1

0.2 B

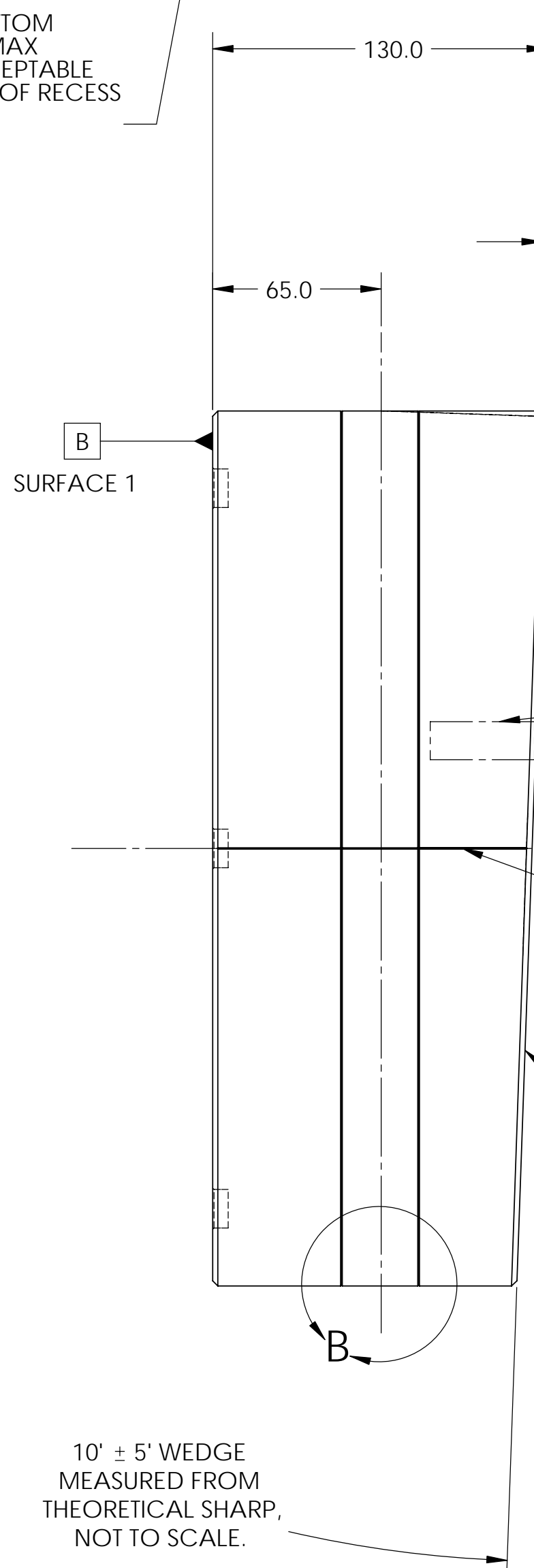

2X, 2.0 ± 0.2 x 45 ± 5° CHAMFER,  
ALL AROUND

ETCH, GRIND OR SANDBLAST PART AND SERIAL  
NUMBER, APPROX WHERE SHOWN,  
LETTERING APPROX 4mm HIGH  
(SEE NOTE 3 BELOW.)

2X, ETCH, GRIND OR SANDBLAST  
LEGIBLE REFERENCE GROOVE  
(GROOVE WIDTH 0.25mm MIN, 0.5mm MAX.)  
AT 0° AND 180° POSITION,  
PARALLEL TO THE CYLINDRICAL  
AXIS (DEFINED BY DATUM -A-).

SURFACE 2

10° ± 5° WEDGE  
MEASURED FROM  
THEORETICAL SHARP,  
NOT TO SCALE.

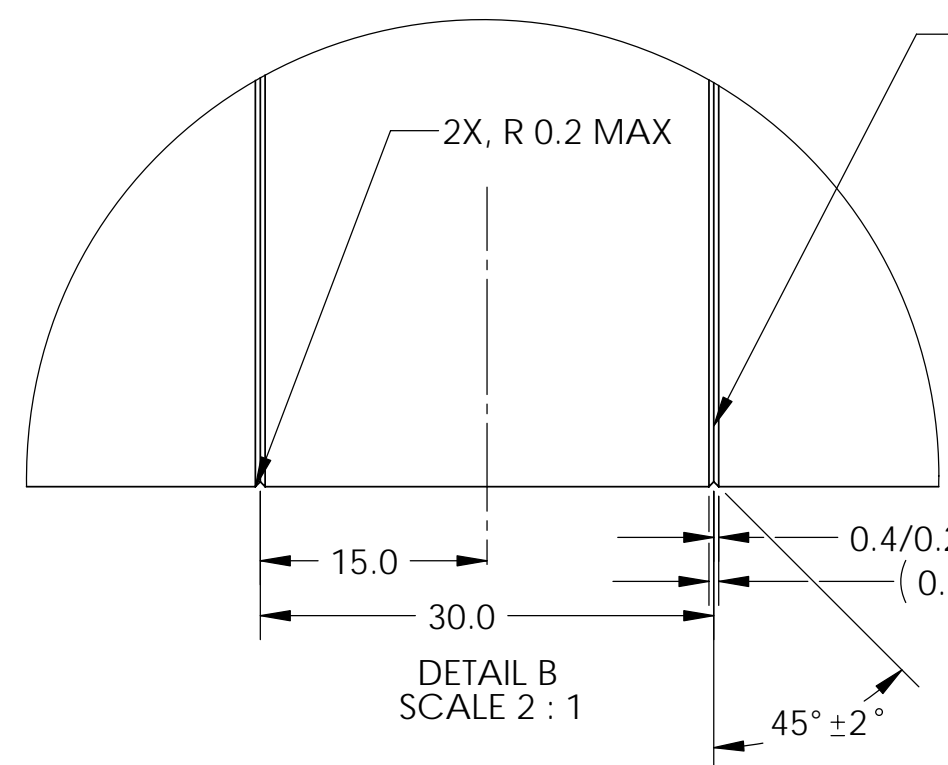

DETAIL B  
SCALE 2:1

THE GROOVES SHOWN IN DETAIL B ARE REQUIRED  
TO LOCATE TWO STEEL WIRE LOOPS,  $\phi 0.46$ mm.  
THE SEPARATION OF THE GROOVES FROM THE CENTERLINE  
AND FROM EACH OTHER IS CRITICAL.  
GROOVES SHOULD BE APPROX "V" SHAPED,  
WITH A MAX RADIUS OF 0.2mm AT THE BASE  
OF EACH GROOVE.

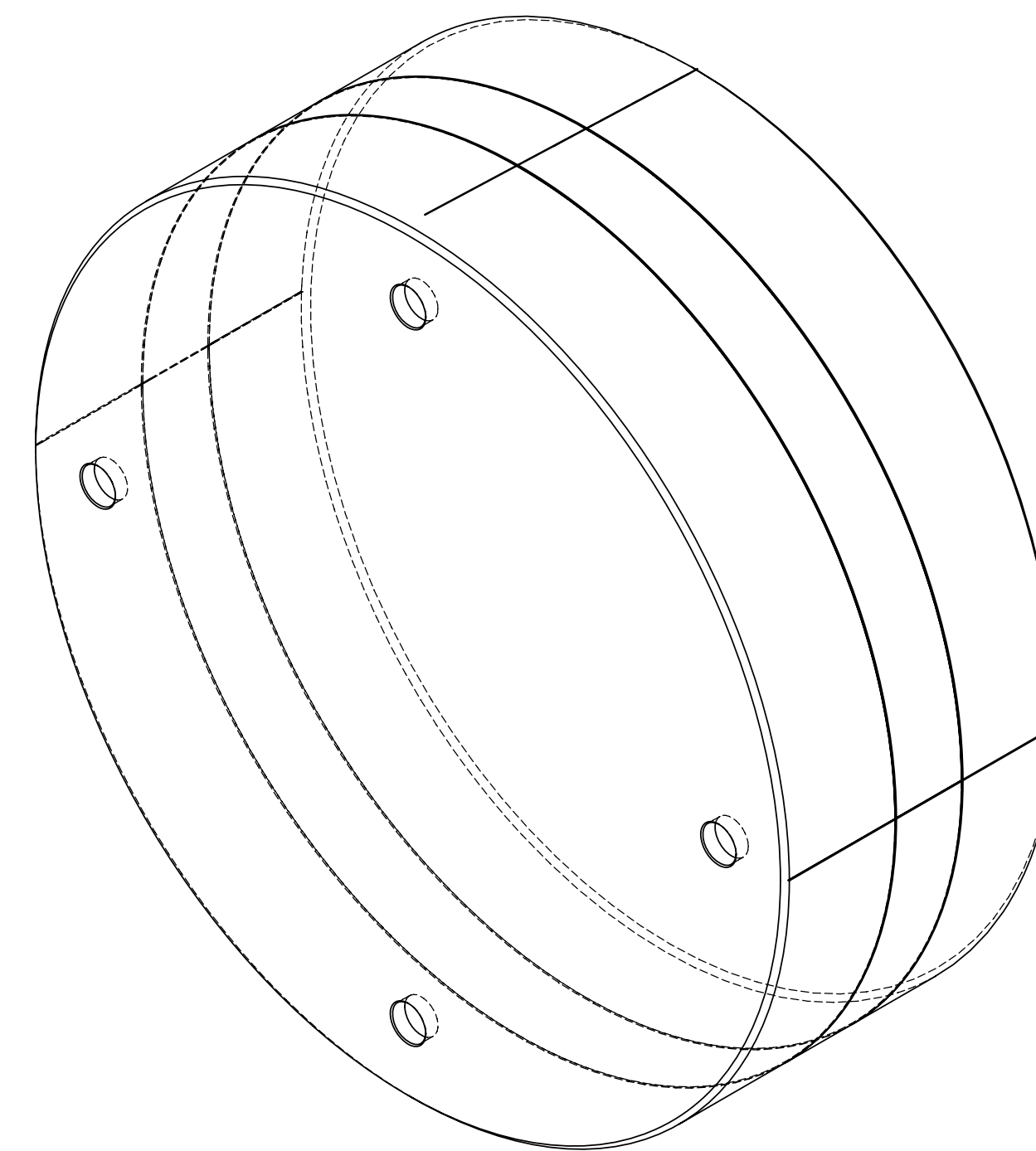

NOTES (UNLESS OTHERWISE SPECIFIED)		PARTS LIST	
1. SHAPE AND POLISH: E060273, FUSED SILICA BLANK, LASTI COMPENSATION PLATE.		LIGO CALIFORNIA INSTITUTE OF TECHNOLOGY MASSACHUSETTS INSTITUTE OF TECHNOLOGY IGR, GLASGOW UNIVERSITY GEO 600 GROUP	
2. SURFACE FINISH: E060274, FUSED SILICA SUBSTRATE, LASTI COMPENSATION PLATE.		SYSTEM: ADVANCED LIGO	
3. INTERPRET DRAWING PER ANSI Y14.5M 1994.		SUB-SYSTEM: SUS	
4. DO NOT SCALE DRAWING		NEXT ASSY: N-PTYPE QUAD ITM	
SEE NOTES		PART NAME: THERMAL COMP PLATE	
FINISH: SEE NOTES		DRAWN: J. Romo	
DRAWN: J. Romo		DATE: DEC06	
CHECKED: APPROVED:		DWG. NO.: D060534	
SCALE: 1:2		PROJECTION: 1st ANGLE	
SHEET 1 OF 1		REV: B	