

REV.	DATE	DCN #	DRAWING TREE #
A	30-OCT-06	E060260-00	

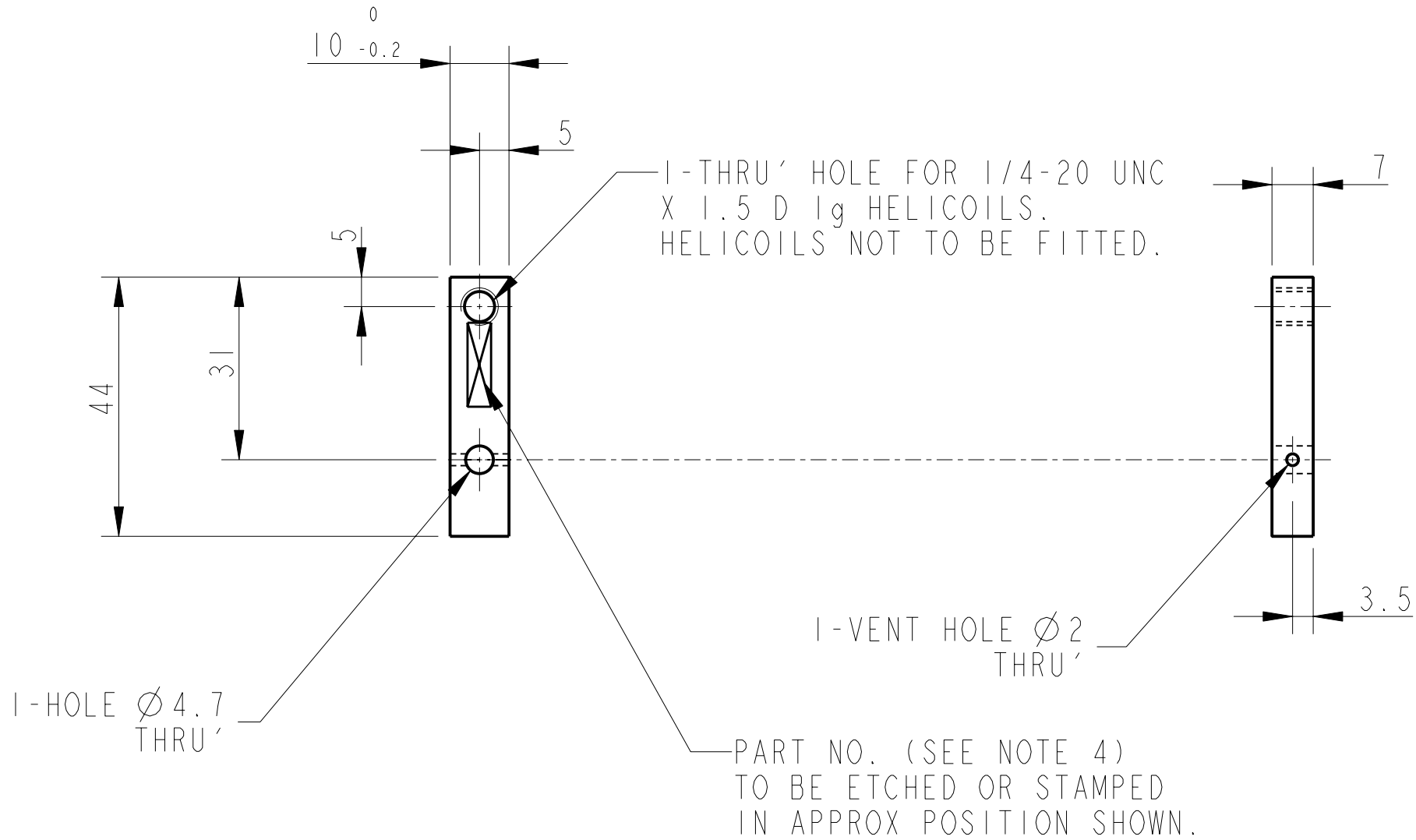

NOTES: (UNLESS OTHERWISE SPECIFIED)		CALIFORNIA INSTITUTE OF TECHNOLOGY MASSACHUSETTS INSTITUTE OF TECHNOLOGY IGR, GLASGOW UNIVERSITY GEO 600 GROUP RUTHERFORD APPLETON LABORATORIES												
1. REMOVE ALL SHARP EDGES, R.02 MIN. 2. DO NOT SCALE FROM DRAWING. 3. ALL MACHINING FLUIDS SHALL BE WATER SOLUBLE AND FREE OF SULFUR, CHLORINE AND SILICONE, SUCH AS CINCINNATI MILACRON'S CIMTECH 410 (STAINLESS STEEL) 4. SCRIBE, ENGRAVE OR STAMP DRAWING PARTNUMBER ON NOTED SURFACE OF PART AND A THREE DIGIT SERIAL NUMBER. SERIAL NUMBERS START AT 001 FOR THE FIRST PART AND PROCEED CONSECUTIVELY. USE .07" HIGH CHARACTERS. EXAMPLE: D020188- 001. A VIBRATORY TOOL MAY BE USED.	DIMENSIONS ARE IN mm [INCHES] TOLERANCES: X.XX ± 0.2 mm \circ ANGULAR $\pm 0.25^\circ$		SYSTEM ADVANCED LIGO											
	MATERIAL: AL. ALLOY 5083 H4 OR 6061		SUB-SYSTEM SUS											
	FINISH: CLEAN $\sqrt{\mu m}$ [μin] Ra = 1.6		NEXT ASSY QUAD N-PYTYPE LOWER STRUCTURE											
	<table border="1"> <thead> <tr> <th></th> <th>NAME</th> <th>DATE</th> </tr> </thead> <tbody> <tr> <td>DRAWN</td> <td>NJS/FEL</td> <td>13/JULY/06</td> </tr> <tr> <td>CHECKED</td> <td>J'OD</td> <td>--/--/--</td> </tr> <tr> <td>APPROVED</td> <td>IW</td> <td>--/--/--</td> </tr> </tbody> </table>			NAME	DATE	DRAWN	NJS/FEL	13/JULY/06	CHECKED	J'OD	--/--/--	APPROVED	IW	--/--/--
	NAME	DATE												
DRAWN	NJS/FEL	13/JULY/06												
CHECKED	J'OD	--/--/--												
APPROVED	IW	--/--/--												
SIZE A DRG. NO. D060480		SCALE 1:1 PROJECTION: SHEET 1 OF 1												