

26

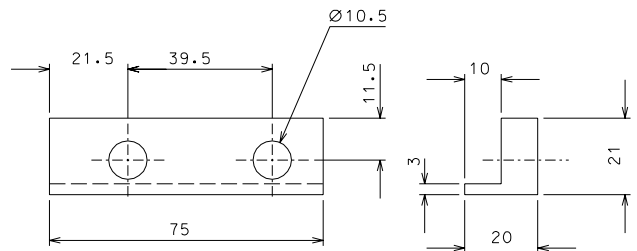

27

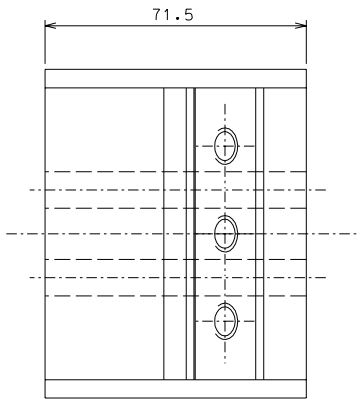
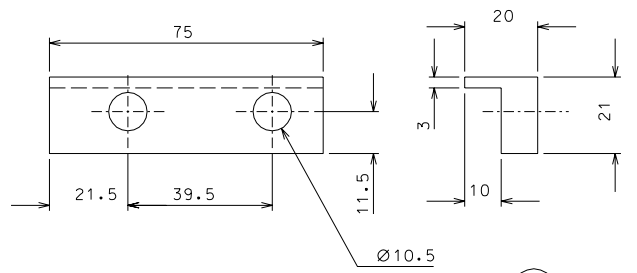
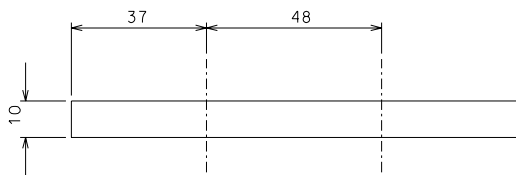

28

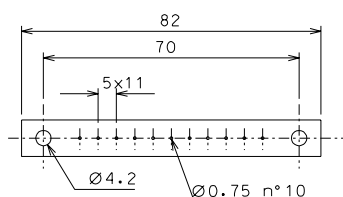

72

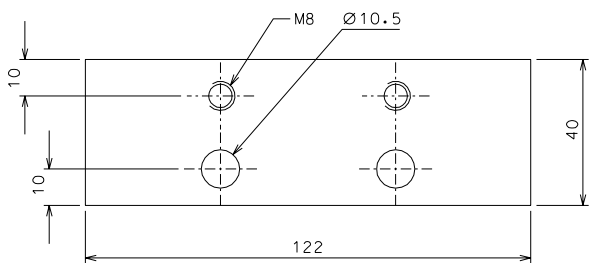

24 nickel flashing

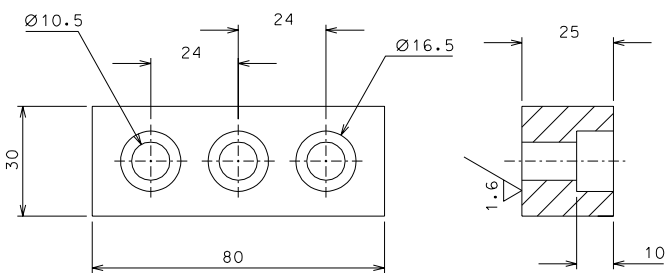

21

		eliminated part 72	06-05-06	
		modified detail 26	09-04-06	
		modified n° parts of detail 28	10-02-06	
ref.	note	date	signature	
modifications				
28	32	AISI 304	1/1	
27	32	AISI 304	1/1	
26	32	AISI 304	1/1	
24	32	Fe 360	1/1	
21	32	AISI 304	1/1	
ref.	pieces	mat. and treatments	scale	
72		peek 1000	1/1	
ref.	pieces	mat. and treatments	scale	

General machining tolerances UNI 5307-63								
Dimensions	< 6	= 6-30	> 30-120	> 120-315	> 315-1000	> 1000-2000	> 2000-4000	> 4000
Linear Toli.	± 0.1	± 0.2	± 0.3	± 0.5	± 0.8	± 1.2	± 2	± 3
angular Toli.	± 1'	± 30'	± 20'	± 10' referred to the shortest side				
designed for						R.De Salvo		
draw. by						G. Gennaro-PROMECC		
date						30-12-04		
title						scale 1/1		
HAM-OPTICAL BENCH						LIGO-D051123-03-D		
DETAILS FILTER						detail from 105-106 A 2		