

LTR		ZONE	DESCRIPTION	REVISIONS											
DWN	CHK	ENGR	STRESS	MATL	THRM	ME	PROJ	QA	RELEASE DATE						
A															

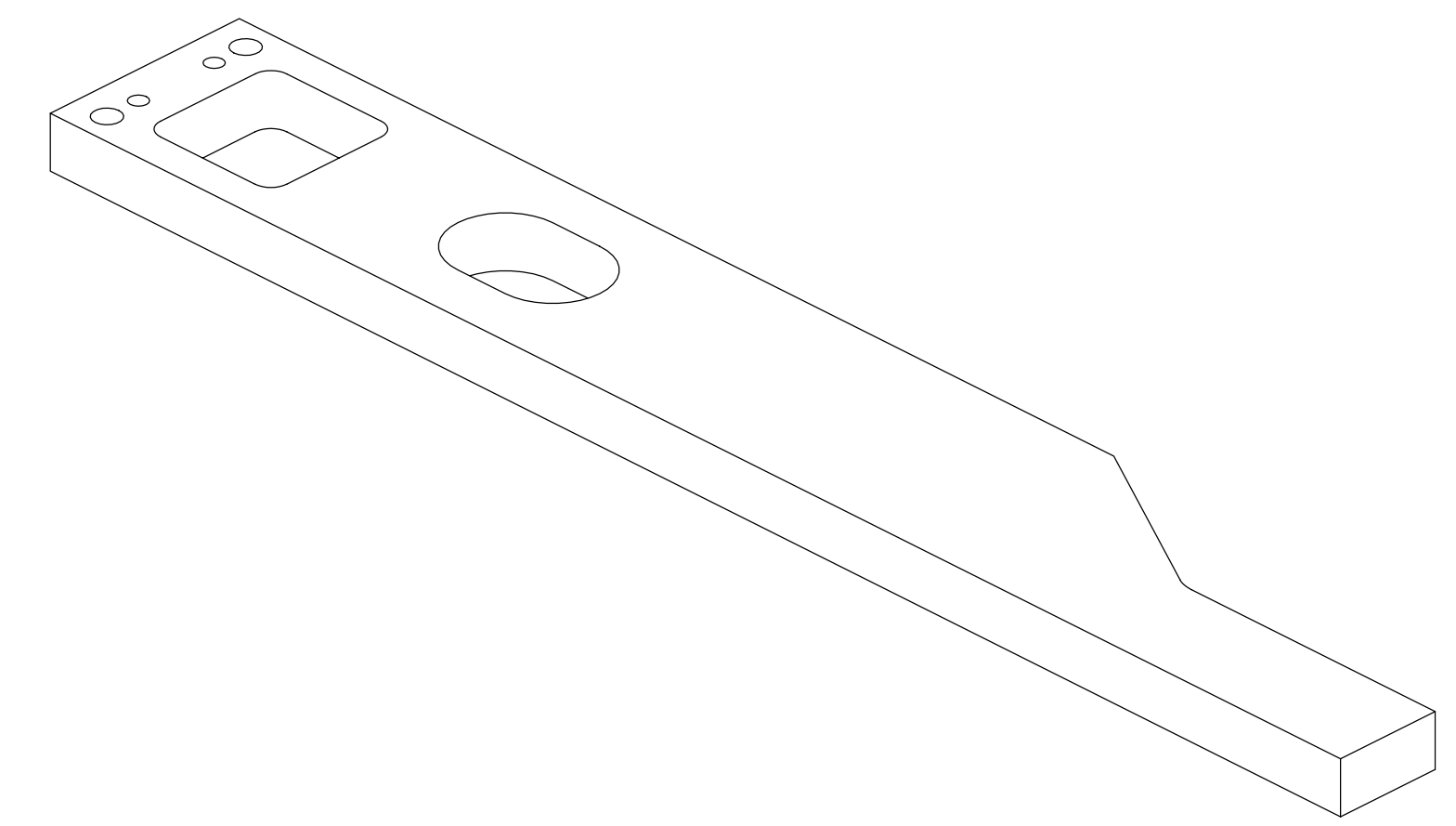
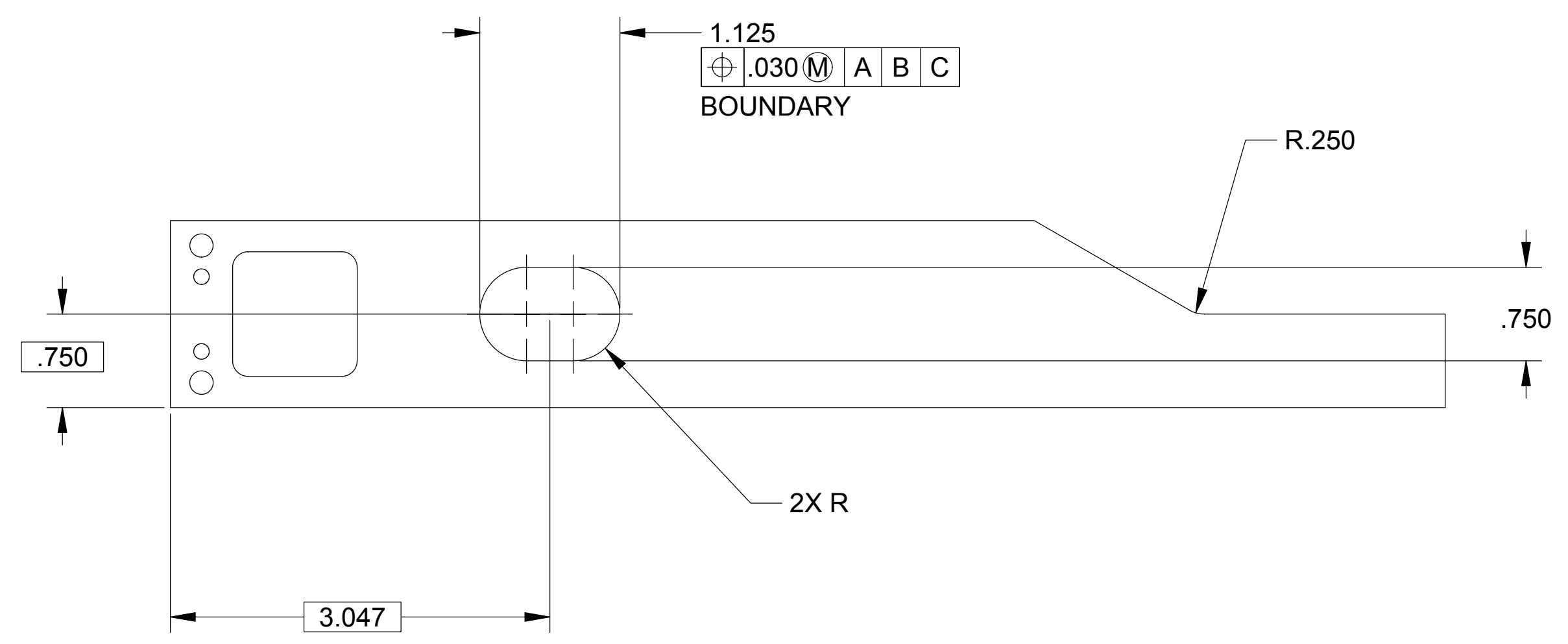
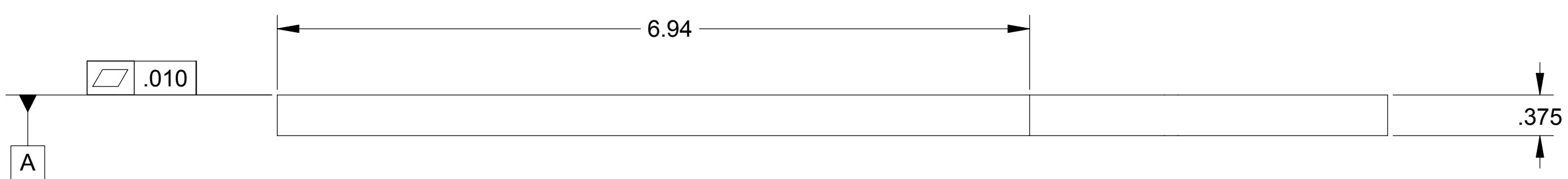
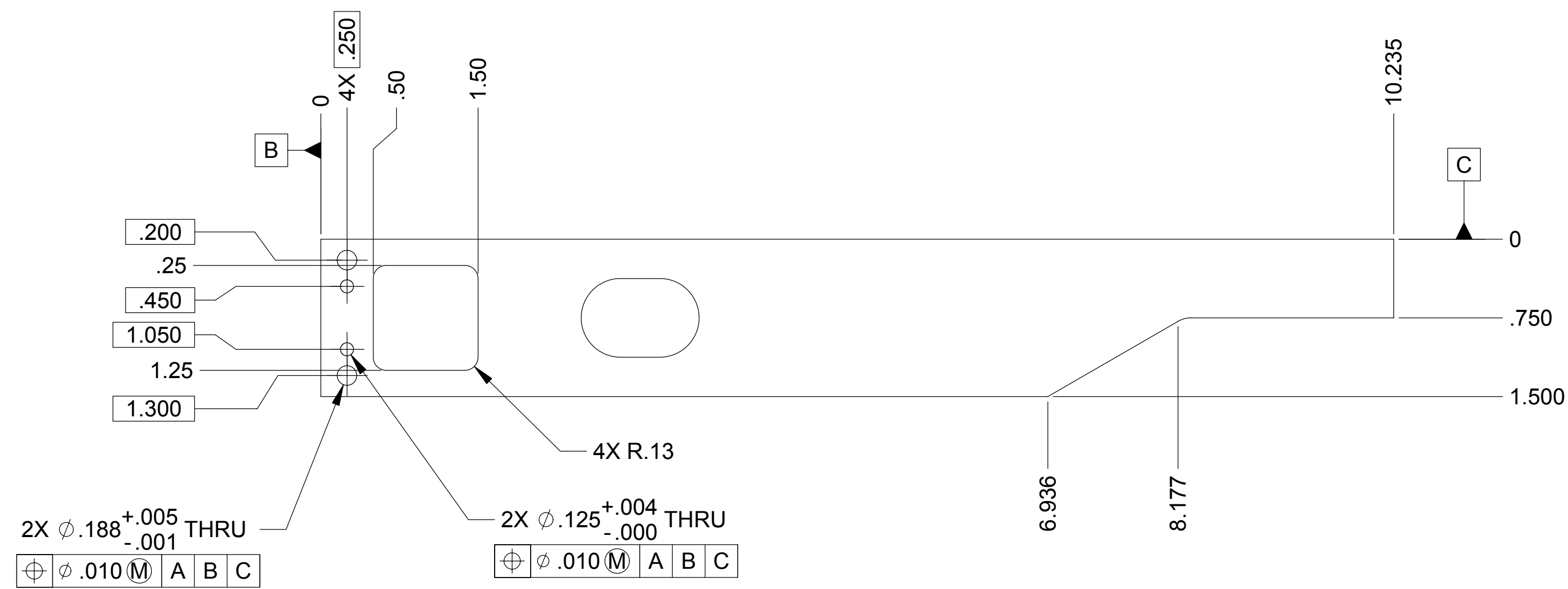

REFERENCE ONLY

- NOTES: UNLESS OTHERWISE SPECIFIED.
- REMOVE ALL BURRS AND SHARP EDGES .005-.015.
 - MACHINE FILLET RADII .003-.015.

THIS DOCUMENT MAY CONTAIN ITAR CONTROLLED INFORMATION AND/OR COMMERCE CONTROLLED INFORMATION EXPORT RESTRICTIONS MAY APPLY

FILE ATTACHMENTS
20008072.x_t

QTY REQD	ITEM NO	REF DES	CAGE NO	20008072-1	PART OR IDENTIFYING NO	NOMENCLATURE OR DESCRIPTION	SPECIFICATION	MATERIAL OR NOTE	ZONE
PARTS LIST									
CONTRACT NO		UNLESS OTHERWISE SPECIFIED		DIMENSIONS ARE IN INCHES		TOLERANCES		RELEASED 8/31/2004 <small>THIS DRAWING IS FOR INFORMATION ONLY AND NOT UNDER CONFIGURATION CONTROL UNLESS A RED RELEASED STAMP APPEARS THEREON.</small>	
		DECIMALS		.XX ±.03		.XXX ±.010		<small>ANGLES ± 1/2°</small> 63	
		MACHINE FINISH		DO NOT SCALE DRAWING		INTERPRET DWG PER ASME Y14.5M-1994		<small>PROJ ENGR</small> J. LARAMEE <small>STRS</small> 07/27/04 <small>CHK</small> <small>MATL</small> <small>CONFIG</small> <small>PROJ</small> <small>ME</small> <small>QA</small>	
20008050		1388		AL 6061-T651		AMS QQ-A-250/11		<small>SIZE</small> D <small>CAGE CODE</small> 1KNU9 20008072 <small>SCALE</small> 1:1 <small>UNCLASSIFIED</small> <small>SHEET</small> 1 OF 1 <small>REV</small> A	
NEXT ASSEMBLY		PROJECT CODE		APPLICATION				<small>REV</small> A <small>REV</small> 6/04	