

LTR		ZONE		REVISIONS										
				DESCRIPTION	DWN	CHK	ENGR	STRESS	MATL	THRM	ME	PROJ	QA	RELEASE DATE
A				INITIAL RELEASE										

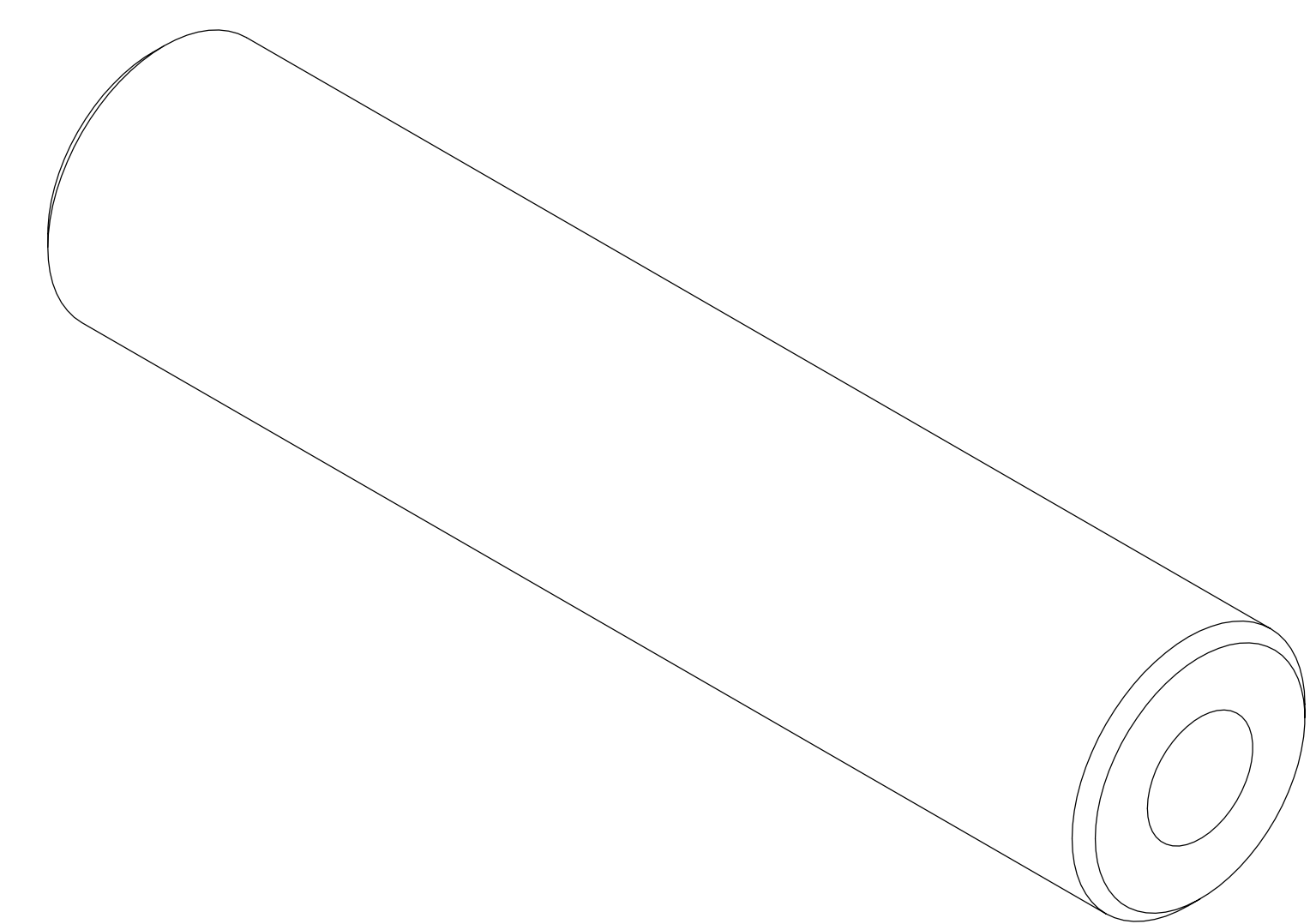
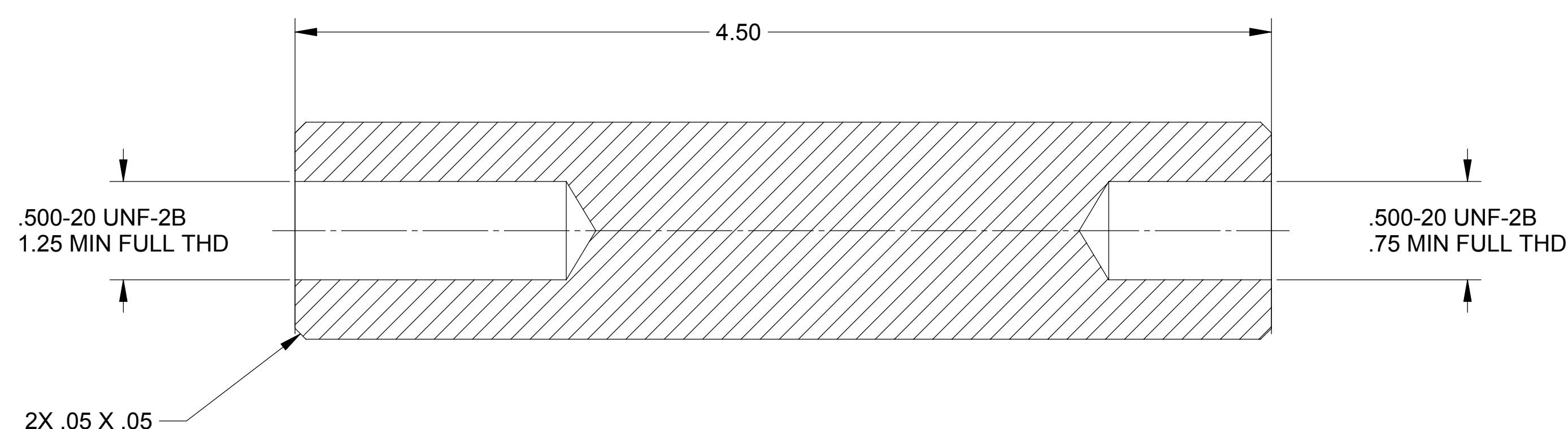
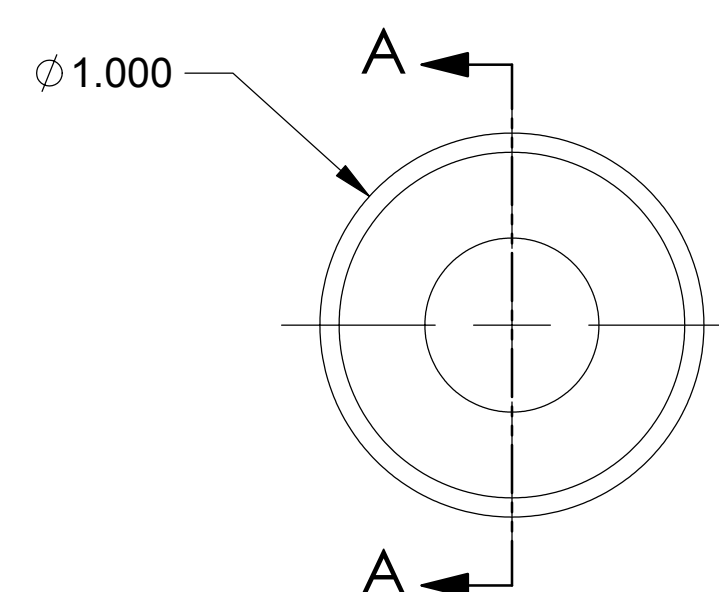

SECTION A-A

REFERENCE ONLY

- NOTES: UNLESS OTHERWISE SPECIFIED.
1. REMOVE ALL BURRS AND SHARP EDGES .005-.015.
 2. MACHINE FILLET RADII .003-.015.

QTY REQD		ITEM NO	REF DES	CAGE NO	20008068-1	PART OR IDENTIFYING NO	NOMENCLATURE OR DESCRIPTION	SPECIFICATION	MATERIAL OR NOTE	ZONE
PARTS LIST										
CONTRACT NO		UNLESS OTHERWISE SPECIFIED		DIMENSIONS ARE IN INCHES		TOLERANCES		RELEASED 8/31/2004 <small>THIS DRAWING IS PRELIMINARY AND NOT UNDER CONFIGURATION CONTROL UNLESS A RED RELEASED STAMP APPEARS HEREIN.</small>		
		DECIMALS .XX ±.03 .XXX ±.010		ANGLES ± 1/2°		63		<small>ASSEMBLY</small> <small>PROJ ENGR</small> J. LARAMEE <small>STRS</small> 07/23/04		
		MACHINE FINISH		DO NOT SCALE DRAWING		INTERPRET DWG PER ASME Y14.5M-1994		<small>CHK</small> <small>MATL</small>		
		MATERIAL		CRES 17-4PH PER H 1150 BASIS B BAR				<small>CONFIG</small> <small>PROJ</small> <small>ME</small> <small>QA</small>		
20008050		1388		NEXT ASSEMBLY		PROJECT CODE		<small>SIZE</small> D <small>CAGE CODE</small> 1KNU9 20008068		<small>REV</small> A
APPLICATION								<small>SCALE</small> 2:1 <small>UNCLASSIFIED</small>		<small>SHEET</small> 1 OF 1 <small>REV</small> 7/04

THIS DOCUMENT MAY CONTAIN ITAR CONTROLLED INFORMATION AND/OR COMMERCE CONTROLLED INFORMATION EXPORT RESTRICTIONS MAY APPLY

D
C
B
A

D
C
B
A

8 7 6 5 4 3 2 1

8 7 6 5 4 3 2 1