

REVISIONS		DWN	CHK	P-ENG	CONFIG	ME	STRS	MATL	PROJ	QA	RELEASE DATE
LTR	ZONE	DESCRIPTION									
A		INITIAL RELEASE									

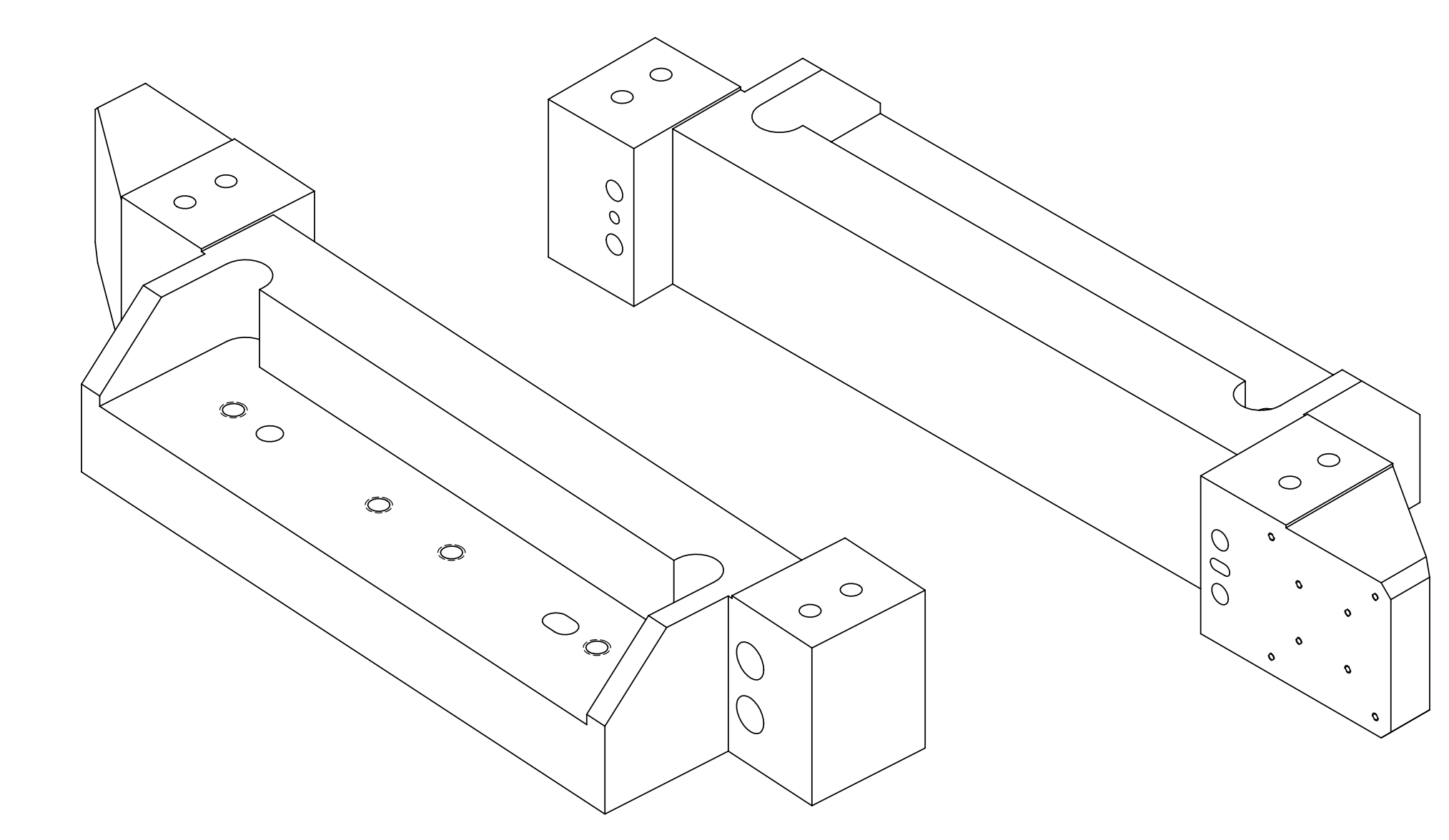
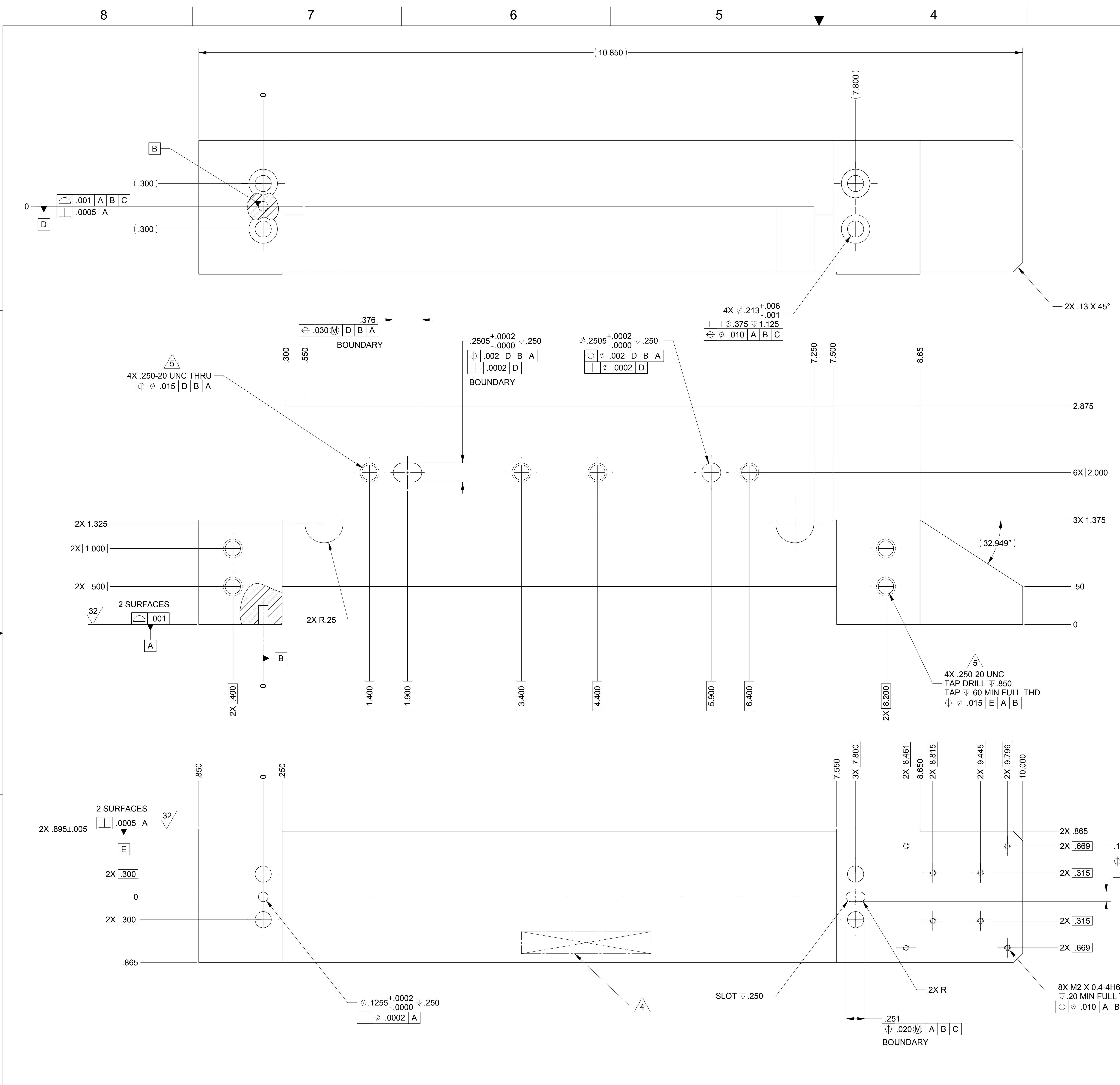

- NOTES: UNLESS OTHERWISE SPECIFIED.
- ALL PARTS SHALL BE MANUFACTURED IN ACCORDANCE WITH ASI SPECIFICATION 20008225 (LIGO E048225).
 - REMOVE ALL BURRS AND SHARP EDGES .005-.015.
 - MACHINE FILLET RADII .003-.015.
 - MARK PART AND SERIAL NUMBER IN LOCATION APPROXIMATELY AS SHOWN USING 0.13-INCH HIGH CHARACTERS IN ACCORDANCE WITH 20006886, TYPE I, CLASSES 4, 5, OR 6. SERIAL NUMBERS START AT 001 FOR FIRST PART AND PROCEED CONSECUTIVELY. PARTS TOO SMALL TO MARK SHALL BE IDENTIFIED IN ACCORDANCE WITH 20006886, TYPE II.

- THREADED HOLES SHALL BE PRODUCED TO A .004-.006 OVERSIZE CONDITION ON THE PITCH DIAMETER BASED ON A 2B CONDITION. THIS DOES NOT APPLY TO THREADED INSERT HOLES OR M2 METRIC HOLES.
- COUNTERSINK 82° ALL TAPPED HOLES TO MAJOR DIAMETER +.015/- .000.
- COUNTERSINK 82° ALL DRILLED HOLES .015-.030 DEEP BOTH SIDES.
- RECORD WEIGHT TO NEAREST 0.1 LB ON INSPECTION REPORT AFTER FINAL MACHINING. ESTIMATED WEIGHT IS 2.7 LBS.

20007906-1											
QTY REQD	ITEM NO	REF DES	CAGE NO	PART OR IDENTIFYING NO	NOMENCLATURE OR DESCRIPTION	SPECIFICATION	MATERIAL OR NOTE	ZONE	PARTS LIST		
CONTRACT NO				UNLESS OTHERWISE SPECIFIED DIMENSIONS ARE IN INCHES TOLERANCES				RELEASED 11/7/2005 ALLIANCE SPACESYSTEMS, INC. 1250 Lincoln Ave., Suite 100 Pasadena, CA 91103			
NEXT ASSEMBLY				MATERIAL				DWN R.D.BILLING 07/12/04 PROJ ENGR STRS CHK MATL CONFIG PROJ ME QA SIZE E CAGE CODE 1KNU9 SCALE 1:1 20007906 UNCLASSIFIED SHEET 1 OF 1			
APPLICATION				AL 7075-T6 AMS-QQ-A-250/12				REV A REV 704			

THIS DOCUMENT MAY CONTAIN ITAR CONTROLLED INFORMATION AND/OR COMMERCE CONTROLLED INFORMATION EXPORT RESTRICTIONS MAY APPLY