

LTR		REVISIONS									
ZONE	DESCRIPTION	DWN	CHK	ENGR	STRESS	MATL	THRM	ME	PROJ	QA	RELEASE DATE
A	INITIAL RELEASE										

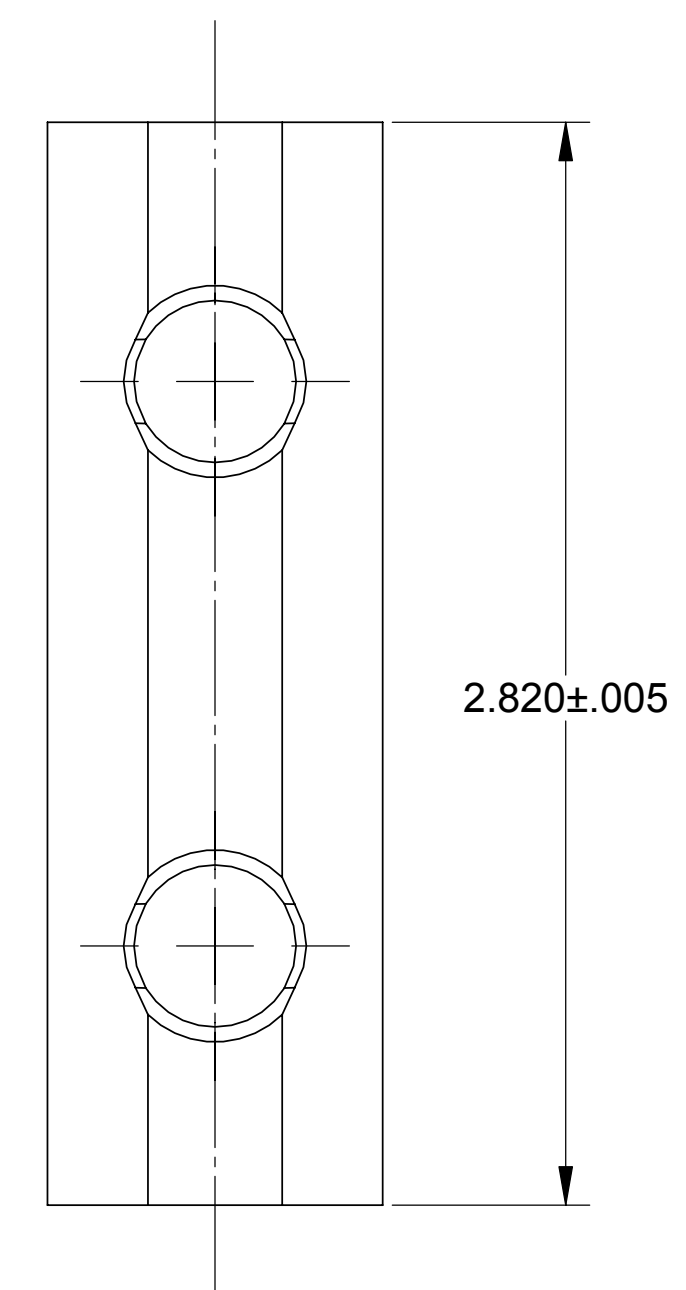

-2 SAME AS -3 EXCEPT AS SHOWN

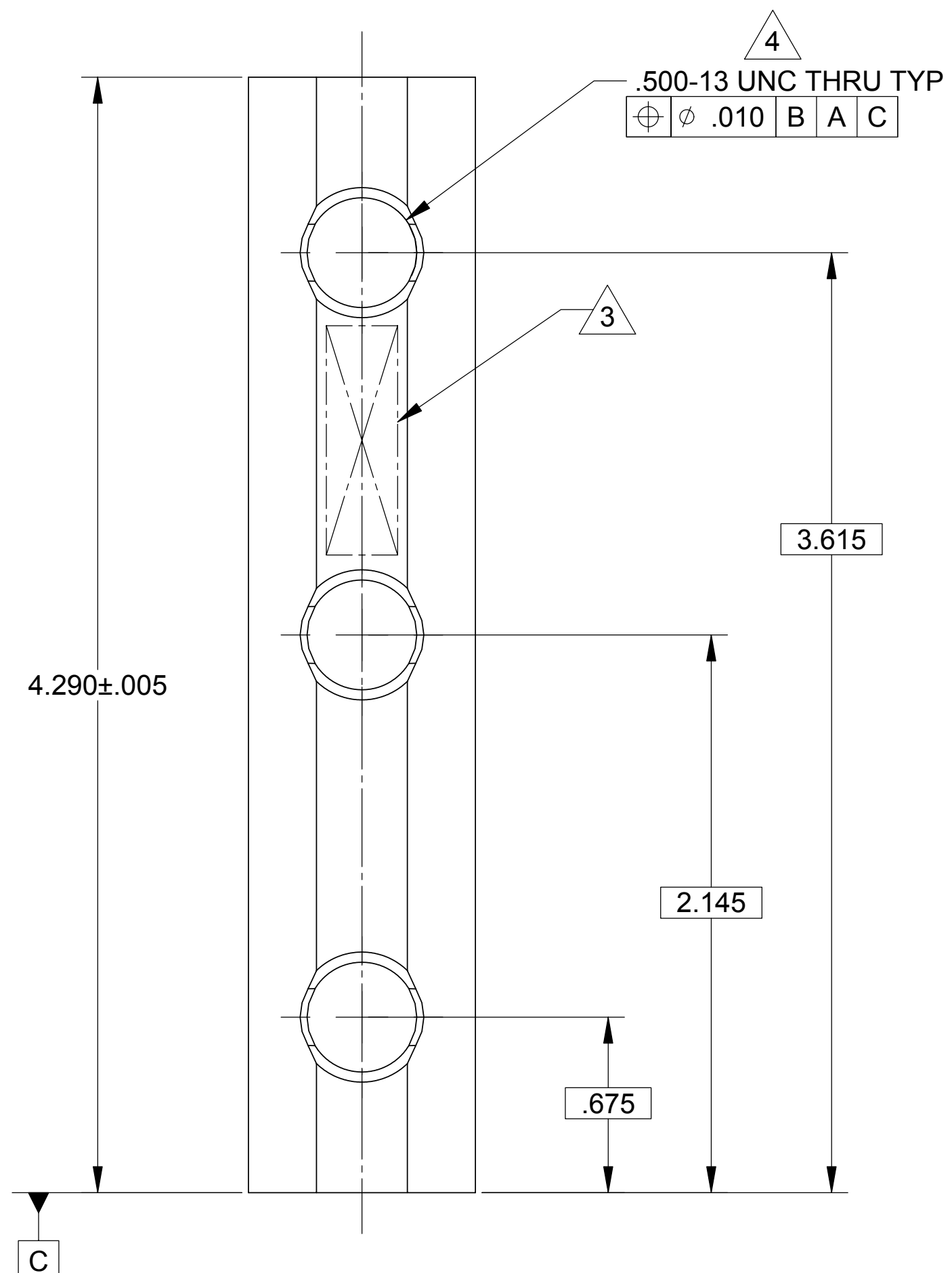
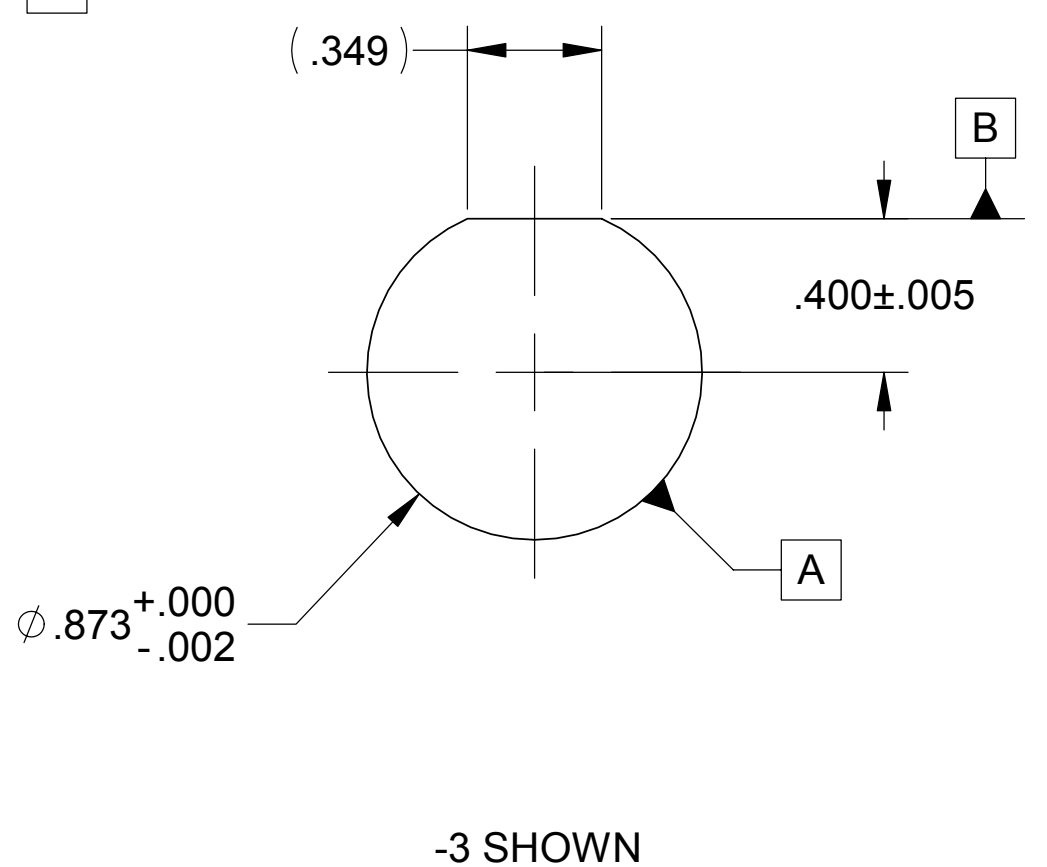
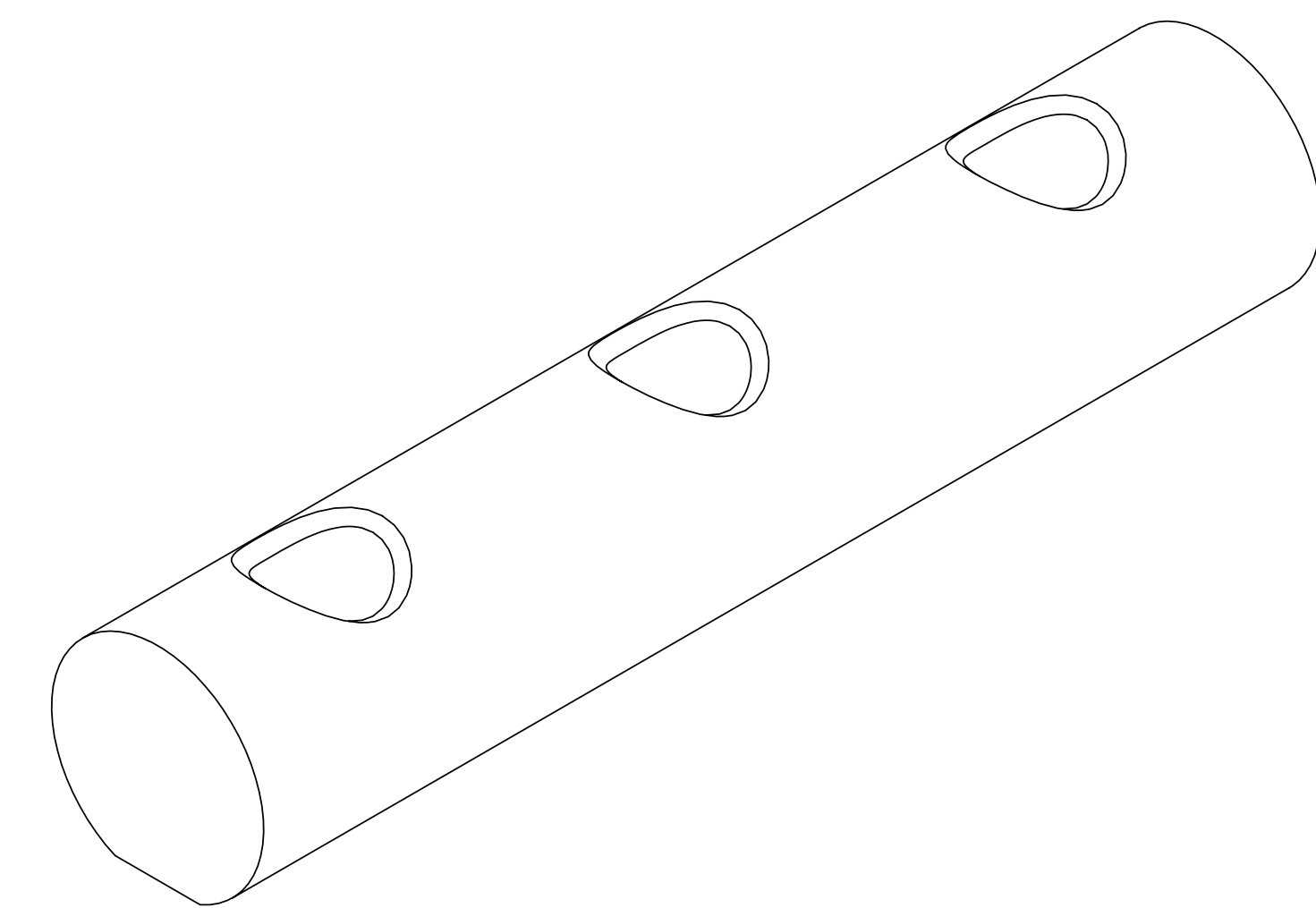

-3 SHOWN

NOTES: UNLESS OTHERWISE SPECIFIED.

- ALL PARTS SHALL BE MANUFACTURED IN ACCORDANCE WITH ASI SPECIFICATION 20008225 (LIGO E048225).
- REMOVE ALL BURRS AND SHARP EDGES .005-.015.
- MARK PART AND SERIAL NUMBER IN LOCATION APPROXIMATELY AS SHOWN USING 0.07-INCH HIGH CHARACTERS IN ACCORDANCE WITH 20006686, TYPE I, CLASSES 4, 5, OR 6. SERIAL NUMBERS START AT 001 FOR FIRST PART AND PROCEED CONSECUTIVELY. PARTS TOO SMALL TO MARK SHALL BE IDENTIFIED IN ACCORDANCE WITH 20006686, TYPE II.
- THREADED HOLES SHALL BE PRODUCED TO A .004-.006 OVERSIZE CONDITION ON THE PITCH DIAMETER BASED ON A 2B CONDITION. THIS DOES NOT APPLY TO THREADED INSERT HOLES.
- COUNTERSINK 82° ALL TAPPED HOLES TO MAJOR DIAMETER +.015/-0.000.
- RECORD WEIGHT TO NEAREST 0.1 LB ON INSPECTION REPORT AFTER FINAL MACHINING. ESTIMATED WEIGHT IS 0.6 LB FOR -3 AND 0.4 LB FOR -2.

20007883-3	BARREL NUT, 3 HOLE
20007883-2	BARREL NUT, 2 HOLE

QTY REQD	ITEM NO	REF DES	CAGE NO	PART OR IDENTIFYING NO	NOMENCLATURE OR DESCRIPTION	SPECIFICATION	MATERIAL OR NOTE	ZONE
					PARTS LIST			
CONTRACT NO		UNLESS OTHERWISE SPECIFIED DIMENSIONS ARE IN INCHES		TOLERANCES		MATERIAL		
		DECIMALS .XX ±.03 .XXX ±.010		ANGLES ± 1/2°		A286 ALLOY PER AMS 5732 SOLUTION TREATED AND AGED TO 130 KSI UTS		
		MACHINE FINISH		63		SCALE 2:1		
		DO NOT SCALE DRAWING INTERPRET DWG PER ASME Y14.5M-1994		MATERIAL		UNCLASSIFIED		
20007878		1388		A286 ALLOY PER AMS 5732 SOLUTION TREATED AND AGED TO 130 KSI UTS		SHEET 1 OF 1		
NEXT ASSEMBLY		PROJECT CODE		APPLICATION		REV A		

ALLIANCE SPACESYSTEMS, INC.
1250 Lincoln Ave., Suite 100
Pasadena, CA 91103

STAGE 0-1
BARREL NUT BAR
LIGO-D047883-A

20007883

THIS DOCUMENT MAY CONTAIN ITAR CONTROLLED INFORMATION AND/OR COMMERCE CONTROLLED INFORMATION EXPORT RESTRICTIONS MAY APPLY

FILE ATTACHMENTS
20007883-2-3.x_t

RELEASED
1/24/2005