

REV.	DATE	DCN #	DRAWING TREE #
A	FEB 17th 2006	E060057-00	E060059-A

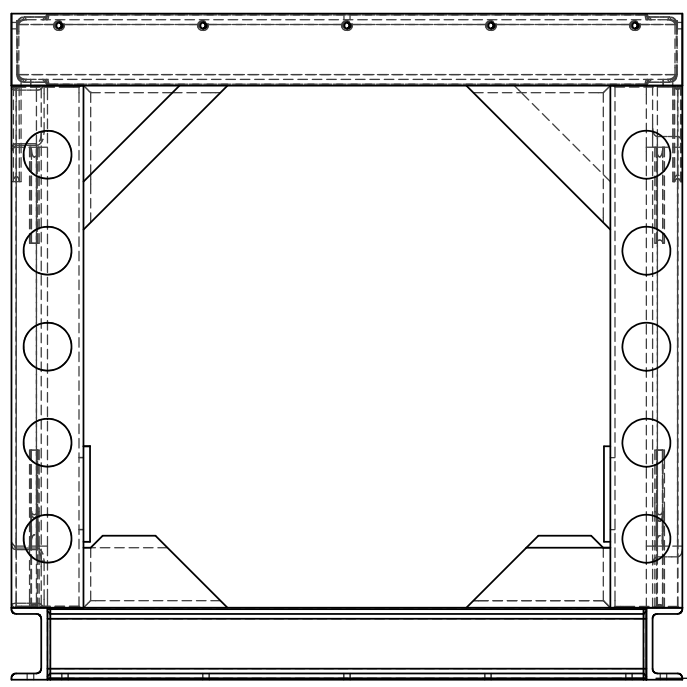

[703.53]
27.70

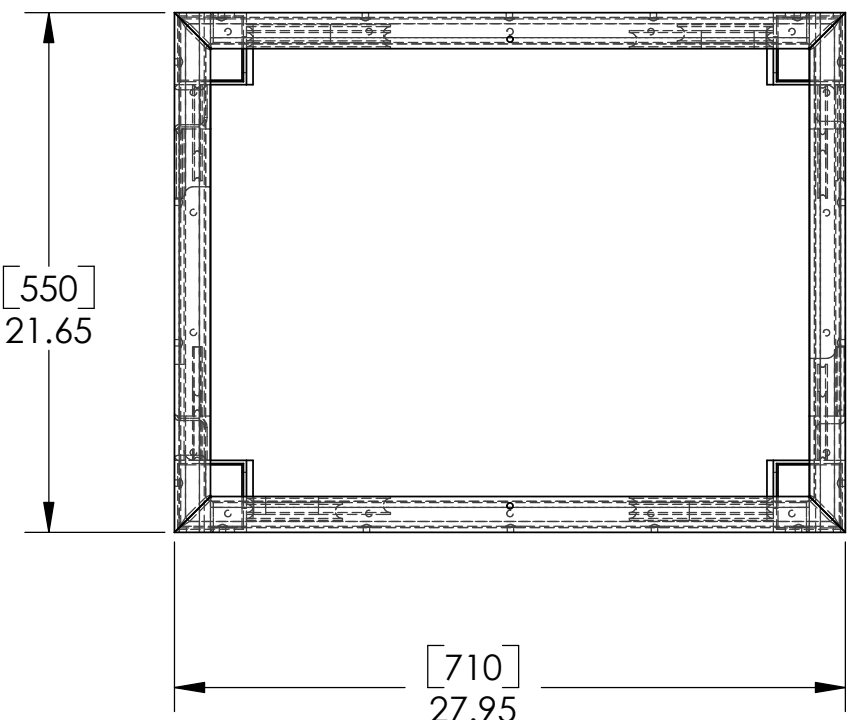
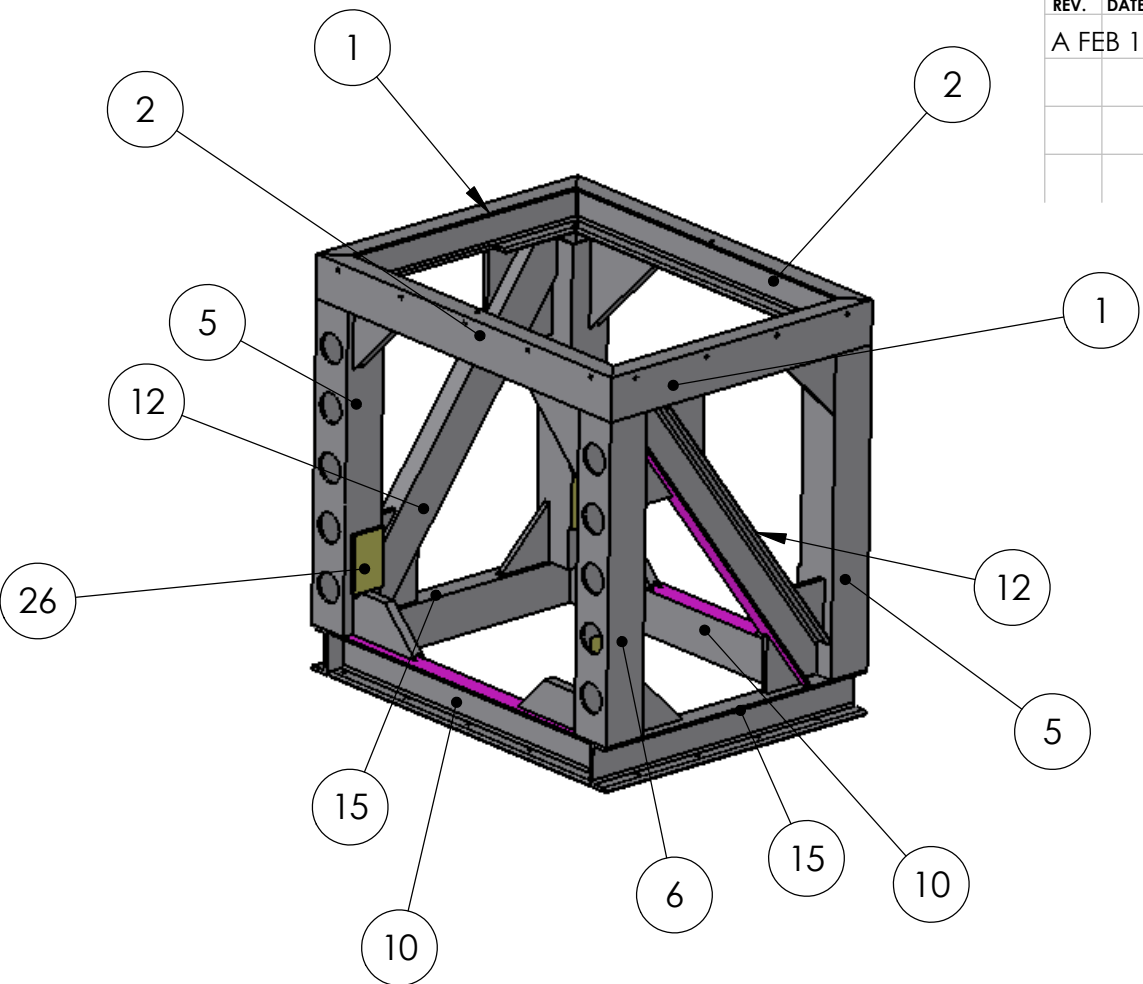

[550]
21.65

[710]
27.95

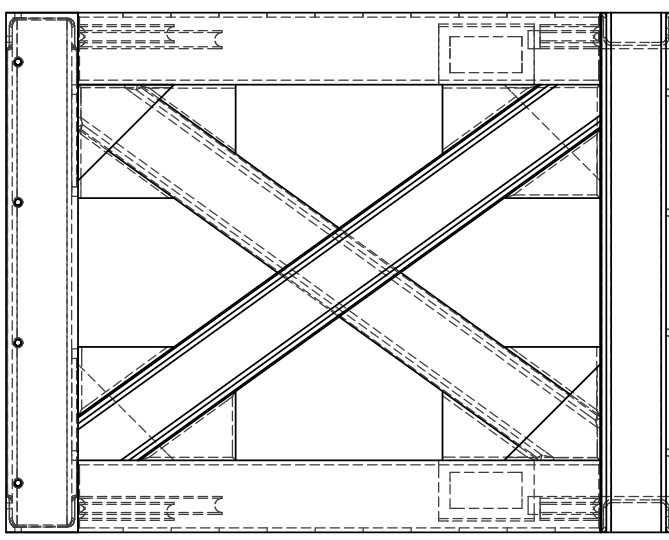

ITEM	QUANTITY	PART NUMBER	MATERIAL
1	2	TD-1039-401	6061-T6-AI
2	2	TD-1039-403	6061-T6-AI
5	2	TD-1039-454	6061-T6-AI
6	2	TD-1039-490	6061-T6-AI
10	2	TD-1039-432	6061-T6-AI
12	2	TD-1039-436	6061-T6-AI
15	2	TD-1039-433	6061-T6-AI
26	4	WELDED PLATES REFERENCE SHEET 3 & 4	6061-T6-AI
XX	X	VARIOUS GUSSET PLATES REFERENCE SHEET 2 & 3	6061-T6-AI

NOTES: (UNLESS OTHERWISE SPECIFIED)

1. DO NOT SCALE FROM DRAWING.
2. REMOVE ALL SHARP EDGES, R.02 MIN.
3. ALL MACHINING FLUIDS SHALL BE WATER SOLUBLE AND FREE OF SULFUR, CHLORINE AND SILICONE.
4. SHEETS ARE ARRANGED IN ORDER OF THE PERFORMED PROCESSES: -
SHEET 1 OF 6 SUMMARY SHOWING PARTS FOR WELDING.
SHEET 2 OF 6 DETAIL VIEWS FOR WELDING.
SHEET 3 OF 6 DETAIL VIEWS FOR WELDING.
SHEET 4 OF 6 POST WELDING MACHINING.
SHEET 5 OF 6 POST WELDING MACHINING.
SHEET 6 OF 6 BOLTED ON SECTIONS.
5. NOTES ARE ALSO INCLUDED ON VARIOUS VIEWS ON THE INDIVIDUAL SHEETS.

INTERNAL NOTE: -
ALL OF THE PARTS HAVE BEEN MODIFIED FOR WELDING. THESE MODIFICATIONS ARE PRESENT IN THE INDIVIDUAL SW PART FILES BUT NOT IN THE .PDFs OF THE DRAWINGS.

DIMENSIONS ARE IN INCHES
TOLERANCES:
.XX ± 0.01
.XXX ± 0.005
ANGULAR ± 0.5 °

FINISH --
-- μ inch

NAME	DATE
DRAWN T HAYLER	MAY 2005
CHECKED C TORRIE	
APPROVED	

PARTS LIST

LIGO CALIFORNIA INSTITUTE OF TECHNOLOGY
MASSACHUSETTS INSTITUTE OF TECHNOLOGY
IGR, GLASGOW UNIVERSITY GEO 600 GROUP

SYSTEM ADVANCED LIGO
SUB-SYSTEM SUS
NEXT ASSY D040401
PART NAME ETM UPPER STR

SIZE DWG. NO. B D040514 REV. A
SCALE: 1:8 PROJECTION: SHEET 1 OF 6

8 7 6 5 4 3 2 1

REV.	DATE	DCN #	DRAWING TREE #
A	FEB 17th 2006	E060057-00	E060059-A

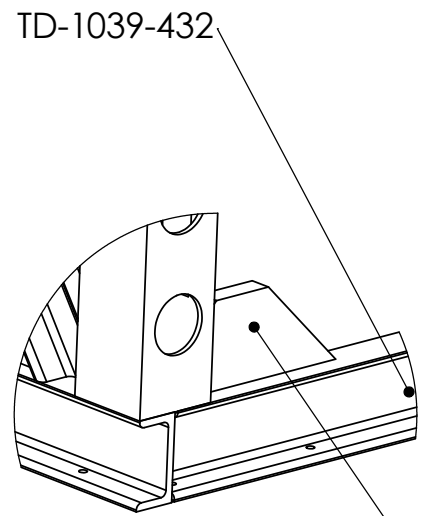
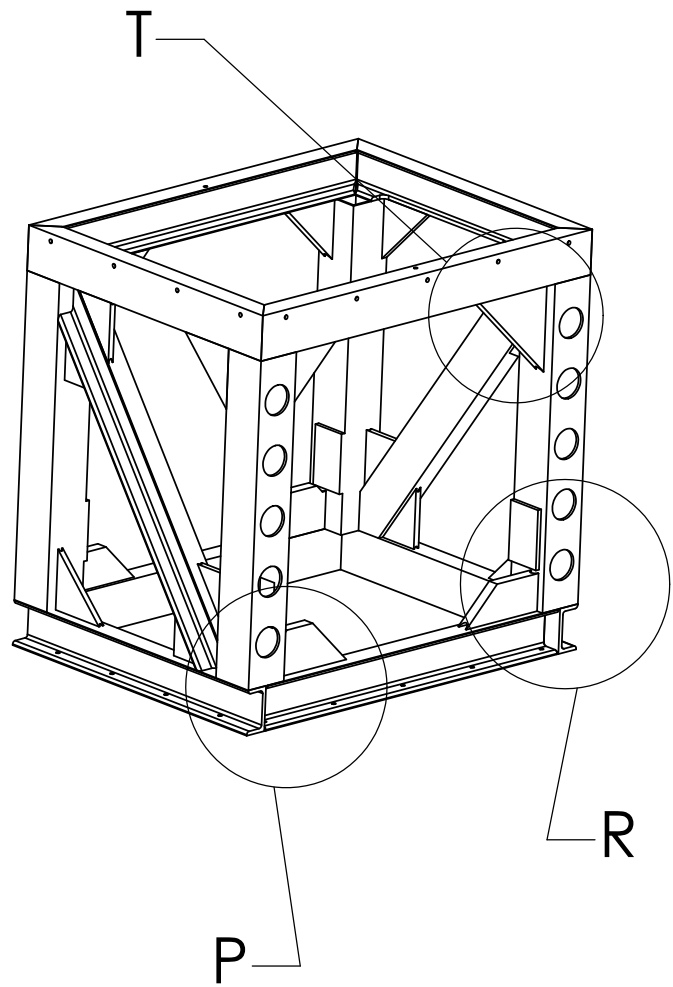

FLUSH WITH INSIDE
 EDGE OF CHANNEL
 SECTION, TD-1039-432.

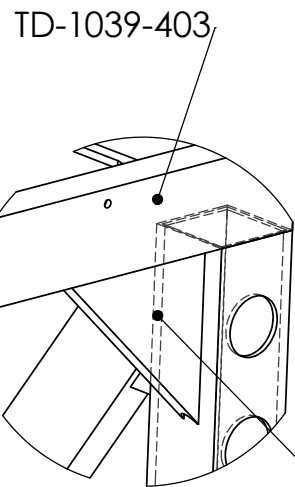
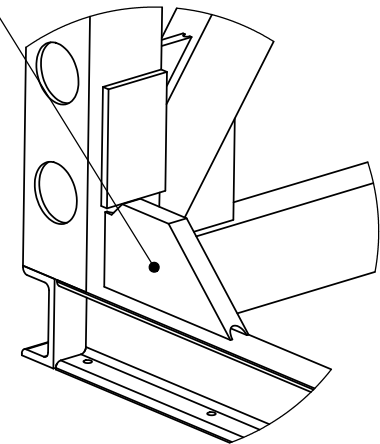
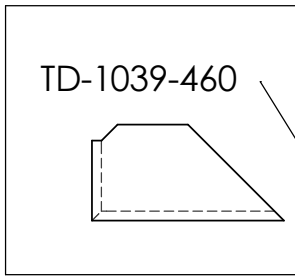

FLUSH WITH INSIDE
 EDGE OF CHANNEL
 SECTION, TD-1039-403.

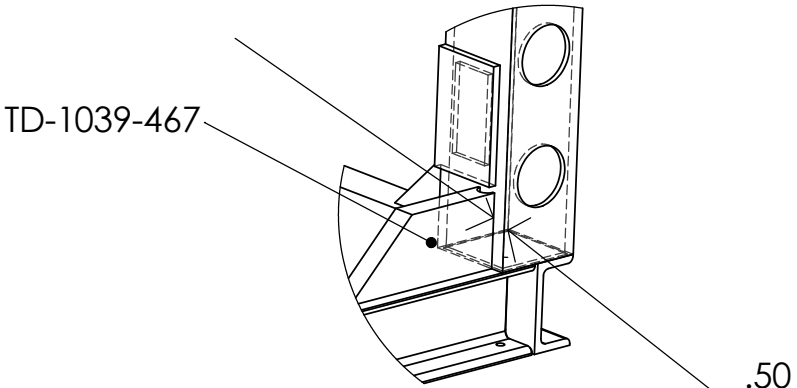
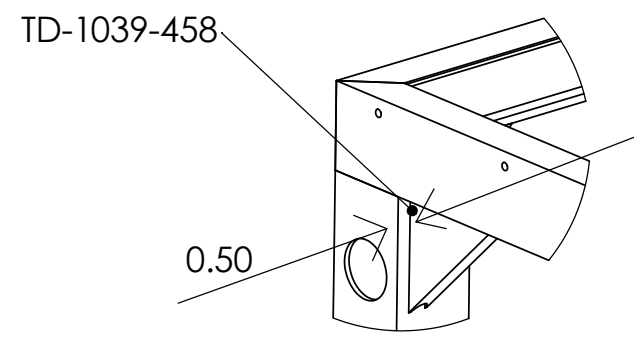
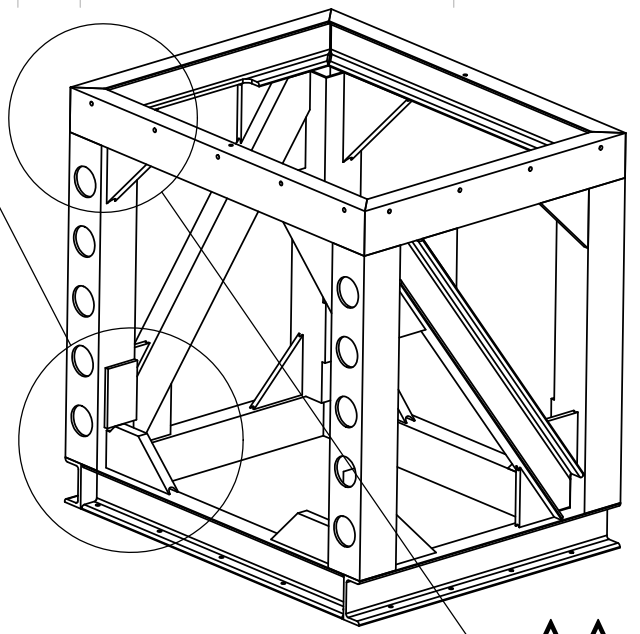

NOTES: (UNLESS OTHERWISE SPECIFIED)			PARTS LIST													
DIMENSIONS ARE IN INCHES			CALIFORNIA INSTITUTE OF TECHNOLOGY MASSACHUSETTS INSTITUTE OF TECHNOLOGY IGR, GLASGOW UNIVERSITY GEO 600 GROUP													
TOLERANCES: .XX ± 0.01 .XXX ± 0.005 ANGULAR ± 0.5°																
MATERIAL			SYSTEM	ADVANCED LIGO												
FINISH			SUB-SYSTEM	SUS												
-- μ inch			NEXT ASSY	D040401												
<table border="1"> <thead> <tr> <th></th> <th>NAME</th> <th>DATE</th> </tr> </thead> <tbody> <tr> <td>DRAWN</td> <td>C TORRIE</td> <td>MAY 2005</td> </tr> <tr> <td>CHECKED</td> <td>T HAYLER</td> <td></td> </tr> <tr> <td>APPROVED</td> <td></td> <td></td> </tr> </tbody> </table>				NAME	DATE	DRAWN	C TORRIE	MAY 2005	CHECKED	T HAYLER		APPROVED			PART NAME ETM UPPER STR	
	NAME	DATE														
DRAWN	C TORRIE	MAY 2005														
CHECKED	T HAYLER															
APPROVED																
<table border="1"> <thead> <tr> <th>SIZE</th> <th>DWG. NO.</th> <th>REV.</th> </tr> </thead> <tbody> <tr> <td>B</td> <td>D040514</td> <td>A</td> </tr> </tbody> </table>			SIZE	DWG. NO.	REV.	B	D040514	A	SCALE: 1:8 PROJECTION: SHEET 2 OF 6							
SIZE	DWG. NO.	REV.														
B	D040514	A														

8 7 6 5 4 3 2 1

REV.	DATE	DCN #	DRAWING TREE #
A	FEB 17th 2006	E060057-00	E060059-A

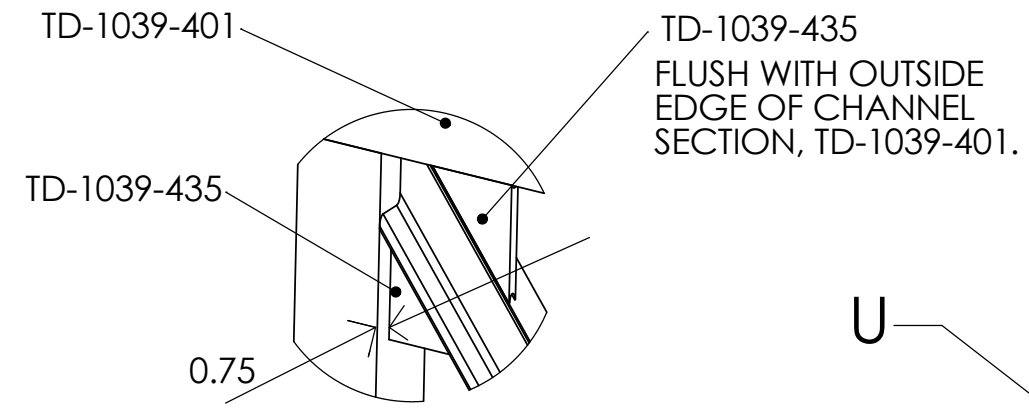
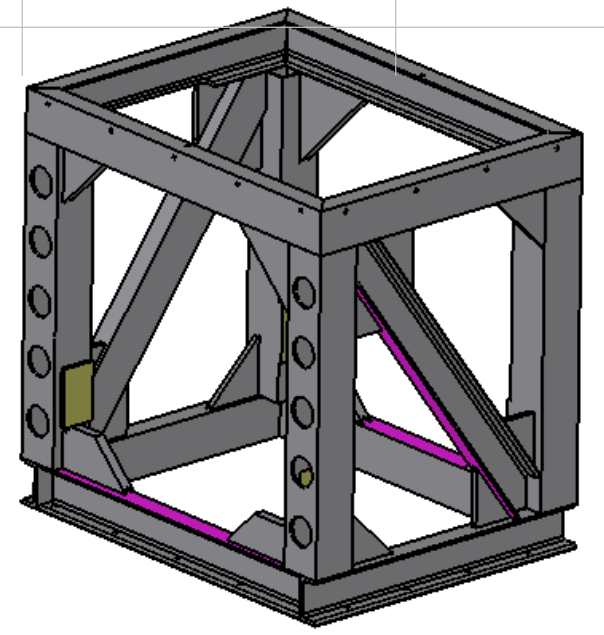

DETAIL U
SCALE 1 : 6

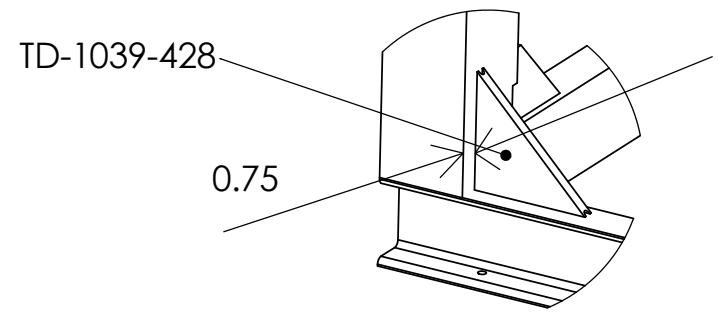

DETAIL Y
SCALE 1 : 6

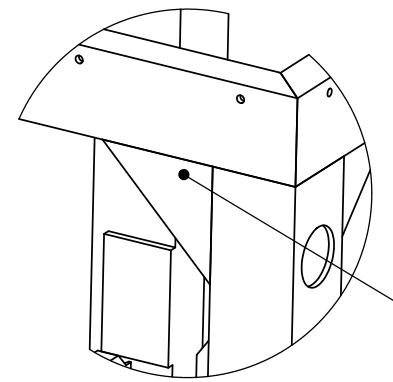
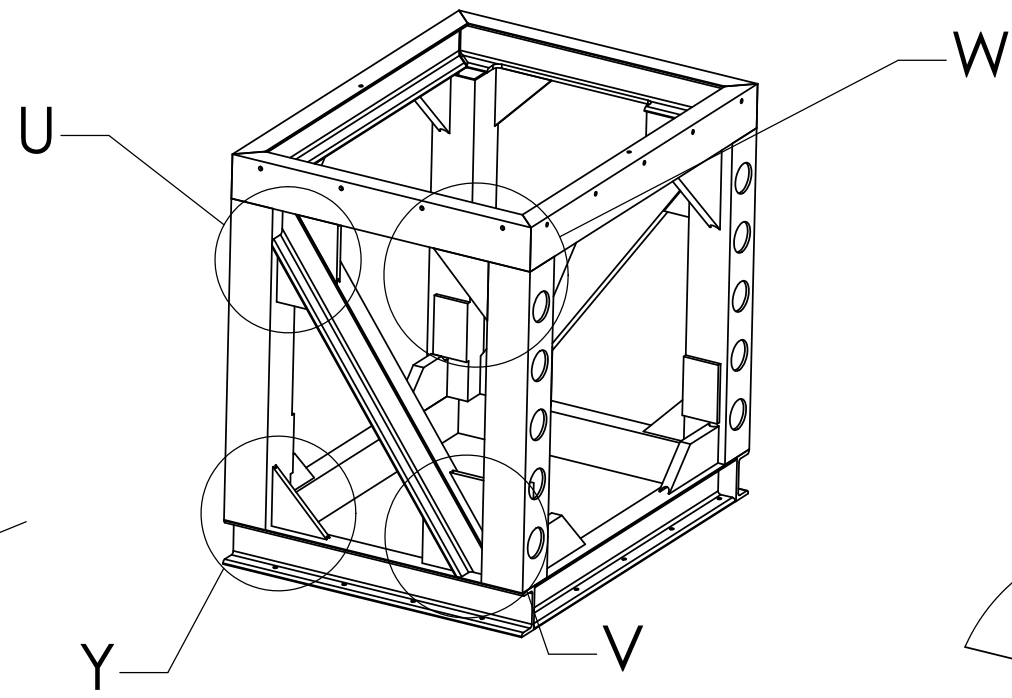

DETAIL W
SCALE 1 : 6

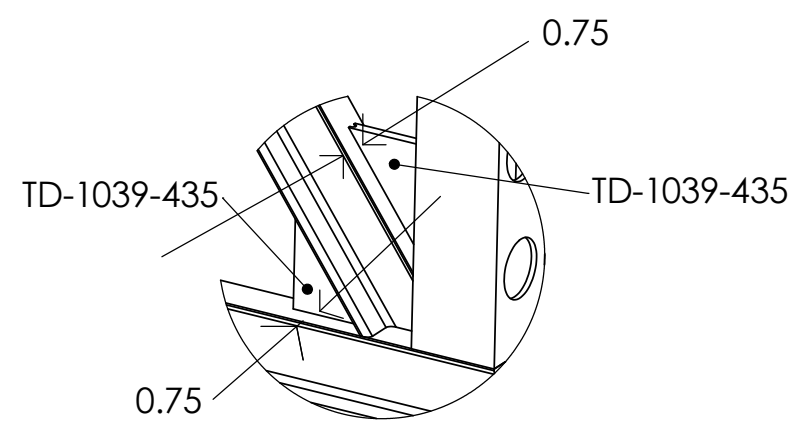

DETAIL V
SCALE 1 : 6

CLOSE UP OF VERTICAL LEG WITH ADDED PLATE, AS SUPPLIED. REFER TO 3D VIEW OF OVERALL ASSEMBLY AS HAVE TWO SIMILAR VERSIONS OF LEG. HOLES SHOULD BE ADDED AFTER WELDING!

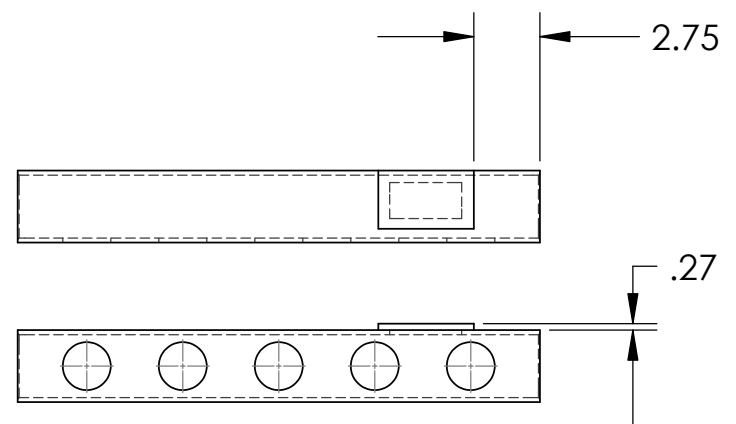

NOTES: (UNLESS OTHERWISE SPECIFIED)			PARTS LIST													
DIMENSIONS ARE IN INCHES			CALIFORNIA INSTITUTE OF TECHNOLOGY MASSACHUSETTS INSTITUTE OF TECHNOLOGY IGR, GLASGOW UNIVERSITY GEO 600 GROUP													
TOLERANCES: .XX ± 0.01 .XXX ± 0.005 ANGULAR ± 0.5 °																
MATERIAL			SYSTEM	ADVANCED LIGO												
FINISH			SUB-SYSTEM	SUS												
-- μ inch			NEXT ASSY	D040401												
<table border="1"> <thead> <tr> <th> </th> <th>NAME</th> <th>DATE</th> </tr> </thead> <tbody> <tr> <td>DRAWN</td> <td>C TORRIE</td> <td>MAY 2005</td> </tr> <tr> <td>CHECKED</td> <td>T HAYLER</td> <td> </td> </tr> <tr> <td>APPROVED</td> <td> </td> <td> </td> </tr> </tbody> </table>				NAME	DATE	DRAWN	C TORRIE	MAY 2005	CHECKED	T HAYLER		APPROVED			PART NAME	ETM UPPER STR
	NAME	DATE														
DRAWN	C TORRIE	MAY 2005														
CHECKED	T HAYLER															
APPROVED																
			SIZE DWG. NO.	B D040514												
			SCALE: 1:12	PROJECTION: SHEET 3 OF 6												
			REV.	A												

8 7 6 5 4 3 2 1

REV.	DATE	DCN #	DRAWING TREE #
A	FEB 17th 2006	E060057-00	E060059-A

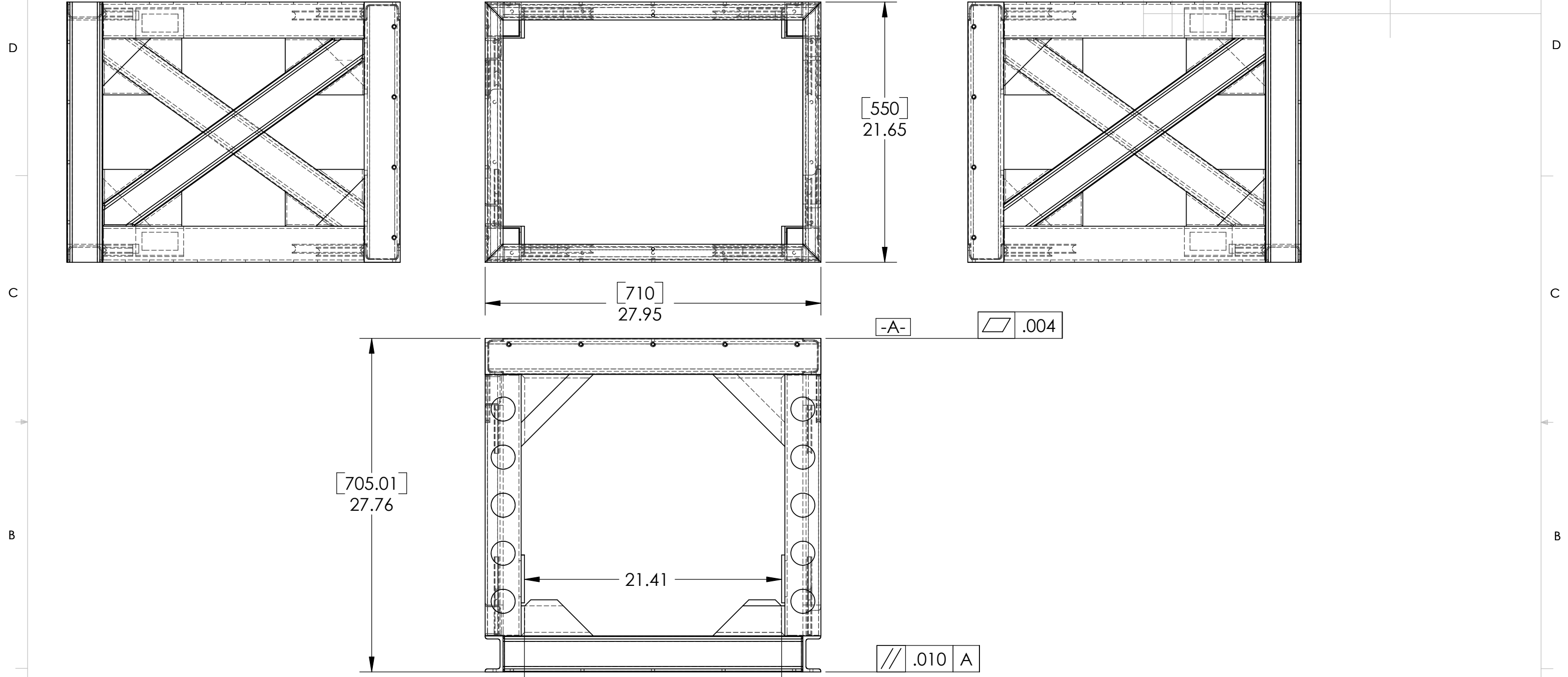

NOTES: (UNLESS OTHERWISE SPECIFIED)			PARTS LIST													
DIMENSIONS ARE IN INCHES			CALIFORNIA INSTITUTE OF TECHNOLOGY MASSACHUSETTS INSTITUTE OF TECHNOLOGY IGR, GLASGOW UNIVERSITY GEO 600 GROUP													
TOLERANCES: .XX ± 0.01 .XXX ± 0.005 ANGULAR ± 0.5°																
MATERIAL			SYSTEM	ADVANCED LIGO												
FINISH			SUB-SYSTEM	SUS												
-- μ inch			NEXT ASSY	D040401												
<table border="1"> <thead> <tr> <th></th> <th>NAME</th> <th>DATE</th> </tr> </thead> <tbody> <tr> <td>DRAWN</td> <td>C.TORRIE</td> <td>MAY 2005</td> </tr> <tr> <td>CHECKED</td> <td></td> <td></td> </tr> <tr> <td>APPROVED</td> <td></td> <td></td> </tr> </tbody> </table>				NAME	DATE	DRAWN	C.TORRIE	MAY 2005	CHECKED			APPROVED			PART NAME	ETM UPPER STR
	NAME	DATE														
DRAWN	C.TORRIE	MAY 2005														
CHECKED																
APPROVED																
			SIZE DWG. NO.	B D040514												
			SCALE: 1:8	PROJECTION: SHEET 4 OF 6												

8 7 6 5 4 3 2 1

REV.	DATE	DCN #	DRAWING TREE #
A	FEB 17th 2006	E060057-00	E060059-A

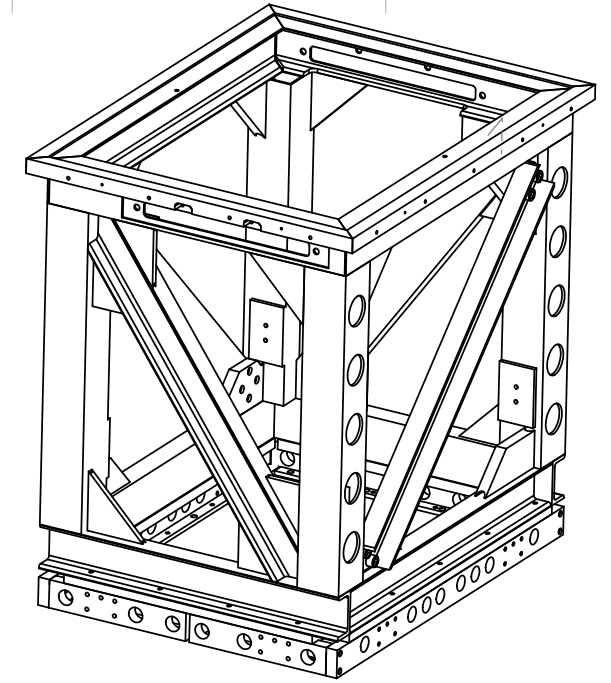
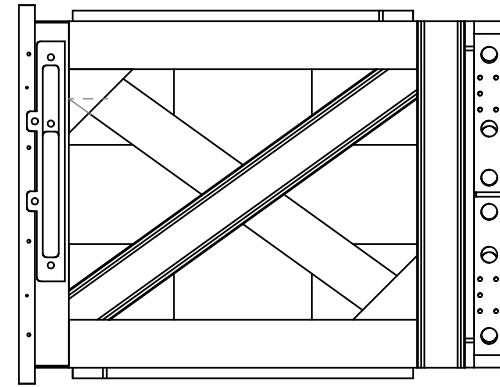
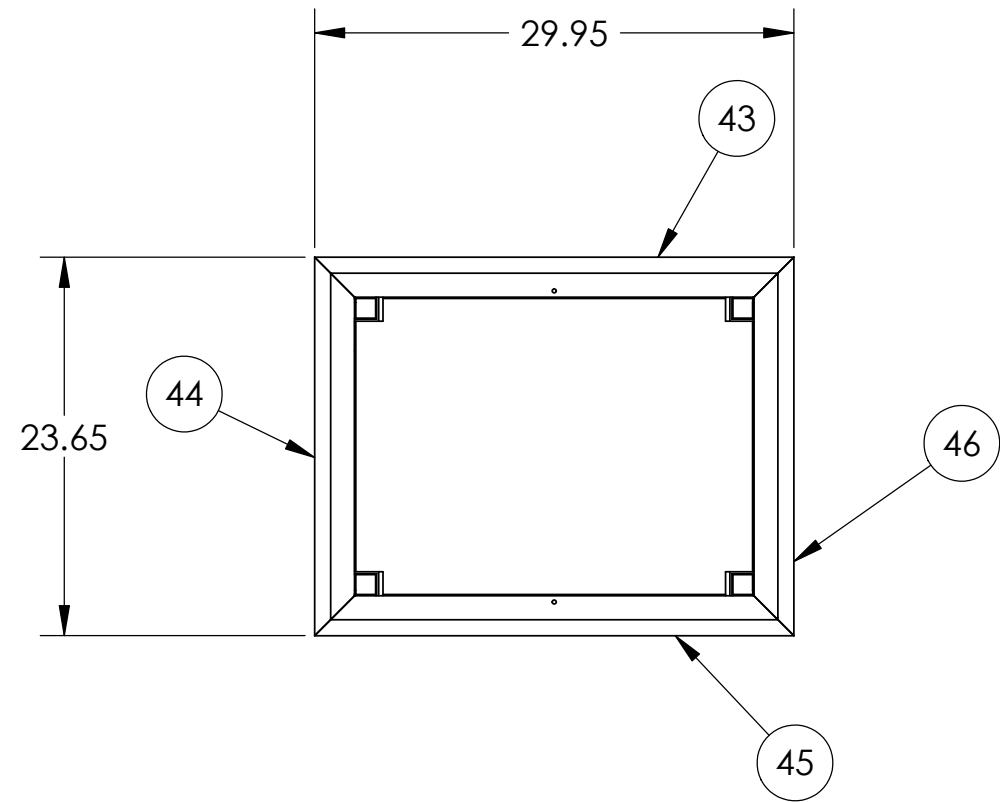

TO BE MADE FLUSH WITH TOP OF WELDED STRUCTURE
REFERENCE DATUM -A-
ON SHEET 4 & 5.

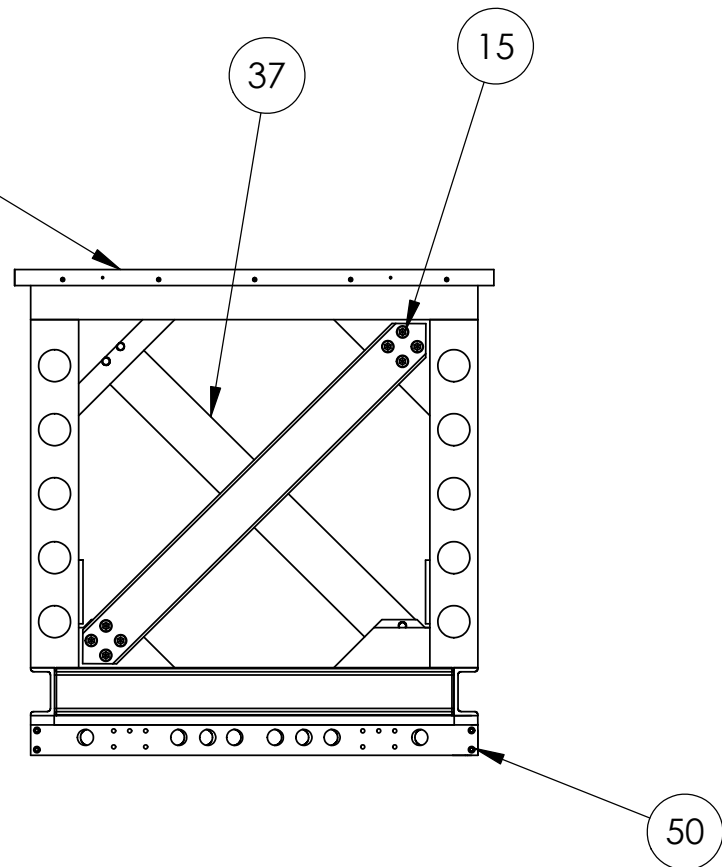

THE FOLLOWING SECTIONS ARE BOLTED ONTO THE STRUCTURE: -

#	QUANTITY	PART	MATERIAL
43	1	TD-1039-483	6061-T6-Al
44	1	TD-1039-484	6061-T6-Al
45	1	TD-1039-485	6061-T6-Al
46	1	TD-1039-486	6061-T6-Al
XX	X	1/4-20 SSTL SHCS x X" LONG	SSTL
37	2	TD-1039-455	6061-T6-Al
15	16	1/2-13 SSTL SHCS x 1" LONG (WITH N-60 INSERTS)	SSTL
51	1	ASSEMBLY TD-1039-410	6061-T6-Al
XX	X	1/4-20 SSTL SHCS x 1" LONG	SSTL

PARTS LIST

NOTES: (UNLESS OTHERWISE SPECIFIED)

DIMENSIONS ARE IN INCHES		
TOLERANCES: .XX ± 0.01 .XXX ± 0.005		
ANGULAR ± 0.5°		
MATERIAL --		
FINISH -- μ inch		
	NAME	DATE
DRAWN	C. TORRIE	MAY 2005
CHECKED		
APPROVED		

LIGO CALIFORNIA INSTITUTE OF TECHNOLOGY
MASSACHUSETTS INSTITUTE OF TECHNOLOGY
IGR, GLASGOW UNIVERSITY GEO 600 GROUP

SYSTEM **ADVANCED LIGO**

SUB-SYSTEM **SUS**

NEXT ASSY **D040401**

PART NAME **ETM UPPER STR**

SCALE: 1:12 PROJECTION: SHEET 6 OF 6

SIZE DWG. NO. **B D040514** REV. **A**