

NOTES: (UNLESS OTHERWISE SPECIFIED)

REV	DATE	DCN #	DRAWING TREE #

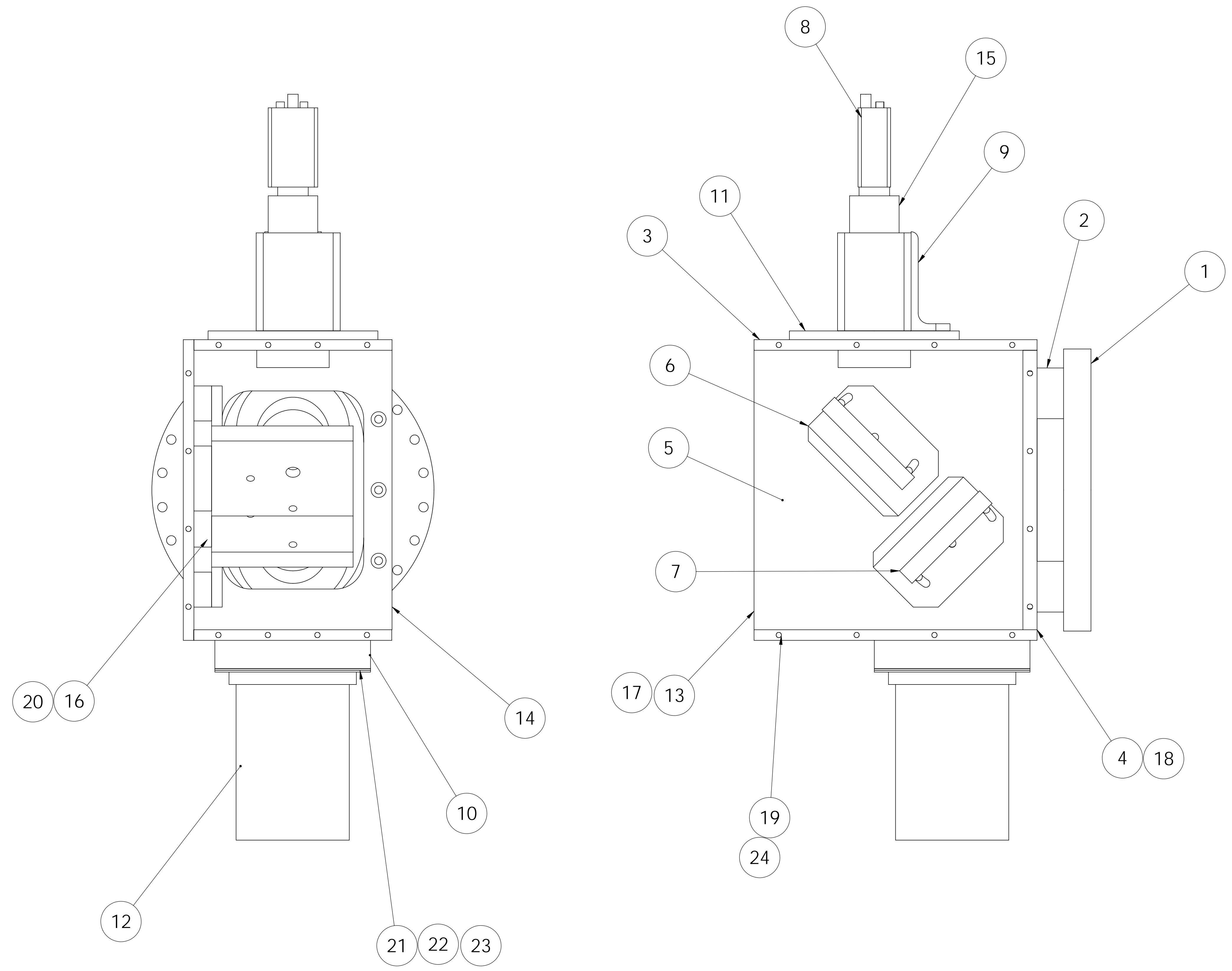

ITEM NO.	PART NUMBER	DESCRIPTION	QTY.
1	031111-1-01	DOUBLE VIEWPORT, NORCAL	1
2	D040010-A	VIEWPORT ADAPTER PLATE	1
3	D040008-A	UPPER PLATE, CAMERA BOX	1
4	D040016-A	FACE PLATE, CAMERA BOX	1
5	D040009-A	SIDE PLATE, CAMERA BOX	1
6	D030803-A	ANGLE MOUNT, MODIFIED	1
7	32071566	ELLIPTICAL MIRROR	1
8	XC-75	CAMERA, SONY	1
9	D040189-A-D	CAMERA ANGLE PLATE	1
10	D040011-A	BEAM TUBE ADAPTER	2
11	D040007-A	CAMERA MOUNTING PLATE	1
12	D040012-A	BEAM TUBE	A/R
13	D040014-A	BACK COVER, CAMERA BOX	1
14	D040013-A	SIDE COVER, CAMERA BOX	1
15	H20 X 15M	ZOOM LENS, RAINBOW	1
16	D040187-A	OPTIC SPACER	1
17	92196A540	1/4-20 X 3/4 LONG SHCS	12
18	-	5/16-18 X 1.0 LONG SHCS	4
19	-	10-32 X .75 LONG SHCS	36
20	-	1/4 -20 X 1.25 LONG SHCS	6
21	-	1/4-20 X 1.75 LONG SHCS	4
22	DO40236-A	BELLOWS	2
23	D040234-A	BACKING PLATE	2
24	D040191-A	LOWER PLATE, CAMERA BOX	1

ITEM NO.	REQ. QUANTITY	SPARE	TOT. QUANTITY	PART NUMBER	DESCRIPTION	SUPPLIER
<b>PARTS LIST</b>						
UNLESS OTHERWISE SPECIFIED:		DATE	NAME	CALIFORNIA INSTITUTE OF TECHNOLOGY MASSACHUSETTS INSTITUTE OF TECHNOLOGY		
DIMENSIONS ARE IN INCHES		DRAWN	5/12/04	SYSTEM		
TOLERANCES:		CHECKED		SUB-SYSTEM		
.XX ± .01				NEXT ASSY		
.XXX ± .005				PART NAME		
ANGULAR ± 1 DEG				LASER THERMAL COMPENSATOR		
MATERIAL		COMMENTS		SIZE	DWG. NO.	REV
FINISH				D	D040208-A-D	A
				SCALE:	SHEET 1 OF 1	