

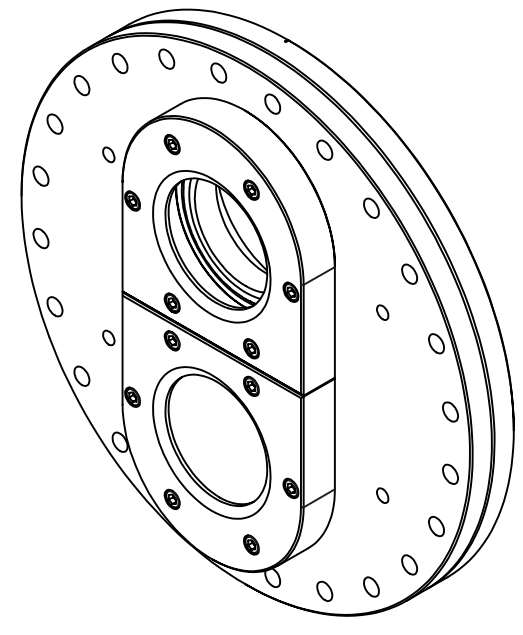

SECTION A-A
SCALE 1 / 3



		DWG. NO. 031111-1			
Rev	Description	Drawn	Date	App'd	ECO
NC	NEW	LF	11/19/2003		11261
P-NC1	ADDED .50 X 45° CHAM	LF	11-26-03		11261
NC1	SPLIT CLAMPING FLG, REMOVED O-RING GROOVE, .580 WAS .510	LF	12-03-03		11261

Parts List			
ITEM	QTY	PART NUMBER	DESCRIPTION
1	1	031111-1-01	MODIFIED 1000-000N, 304 SS
2	2	031111-1-02	CLAMPING FLANGE, ALUMINUM
3	1	VP-300-FS	GLASS, FUSED SILICA
4	2	OR-2-230V	O-RING, VITON
5	12	9551-01032-0	10-32 X 1" LG SHCS, 18-8 SS

- NOTES:
1. METAL WORKING LUBRICANTS WHICH CONTAIN SULFUR OR SILICONE ARE PROHIBITED.
 2. ONLY WATER-SOLUBLE CUTTING FLUIDS ARE PERMITTED.
 3. BREAK ALL SHARP CORNERS .005 RADIUS MAX.
 4. 32 FINISH ON ALL MACHINED SURFACES UNLESS OTHERWISE SPECIFIED.
 5. PARTS SHALL BE CLEAN AND FREE FROM LOOSE CONTAMINANTS, OIL AND GREASE.
 6. MATERIAL: 304 SS CF FLANGE, ALUMINUM CLAMPING FLANGE, VITON O-RING

DO NOT SCALE DRAWING.		Inventor File No: 031111-1	
THIS DOCUMENT SHALL NOT BE REPRODUCED, NOR SHALL THE INFORMATION CONTAINED HEREIN BE USED BY OR DISCLOSED TO OTHERS EXCEPT AS EXPRESSLY AUTHORIZED BY NOR-CAL PRODUCTS.		 Nor-Cal Products, Inc. 1967 South Oregon St./P.O. Box 518, Yreka, CA 96097 1-800-824-4166 or 1-530-842-4457	
Unless otherwise specified Dimensions in Inches		TITLE CUSTOM 10" CF DOUBLE VIEWPORT FLANGE	
X=± 0.035	B SIZE	Customer LIGO	
.XX=± 0.020		Date: 11/19/2003 DRAWN: LF CHECKED:	
.XXX=± 0.005		Sheet: 1 OF 1 DWG NO: 031111-1 REV: NC1	
ANGLES ± 1/2°			
SCALE 1:3			

DWG. NO. 031111-1