

ZONE		REV	DESCRIPTION	DATE	APPROVED

NOTES:
 1. MAKE FROM 8" PIPE (8.625 DIA X .322 WALL).
 2. CLEAR ANODIZE PER MIL-A-8625.

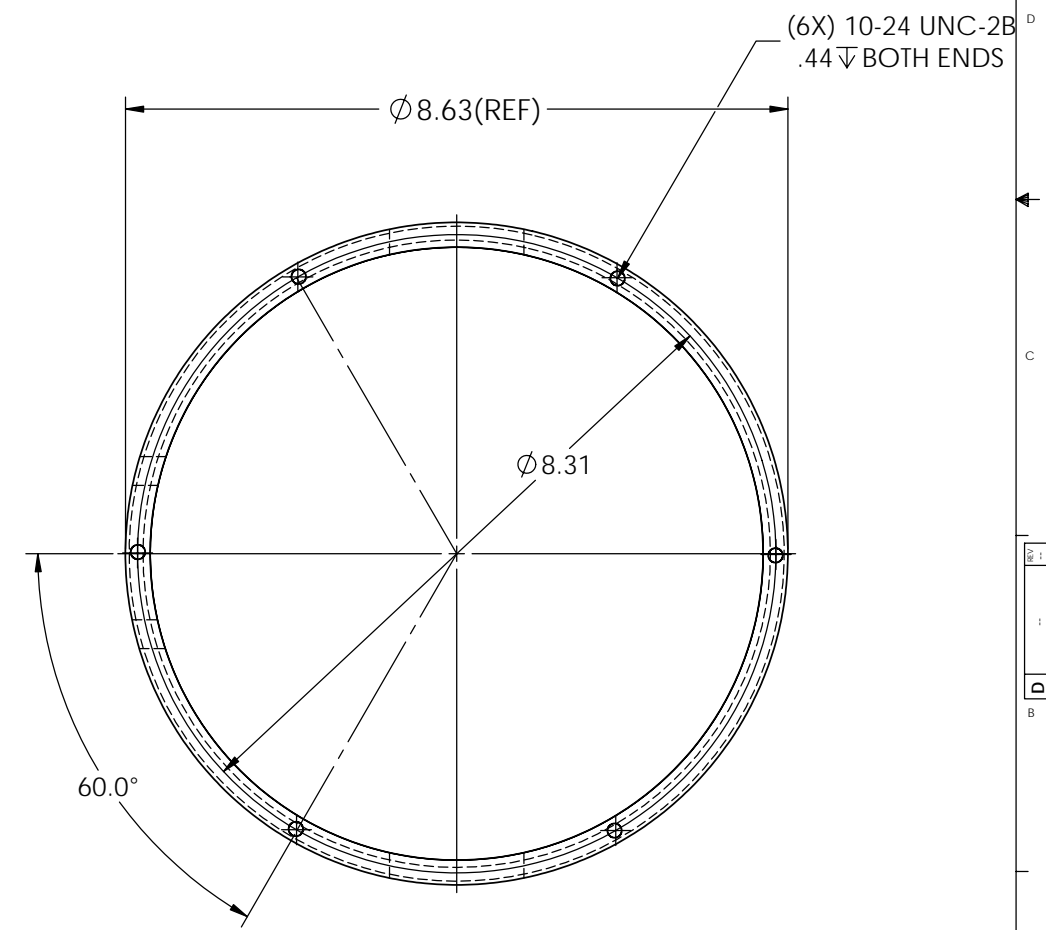
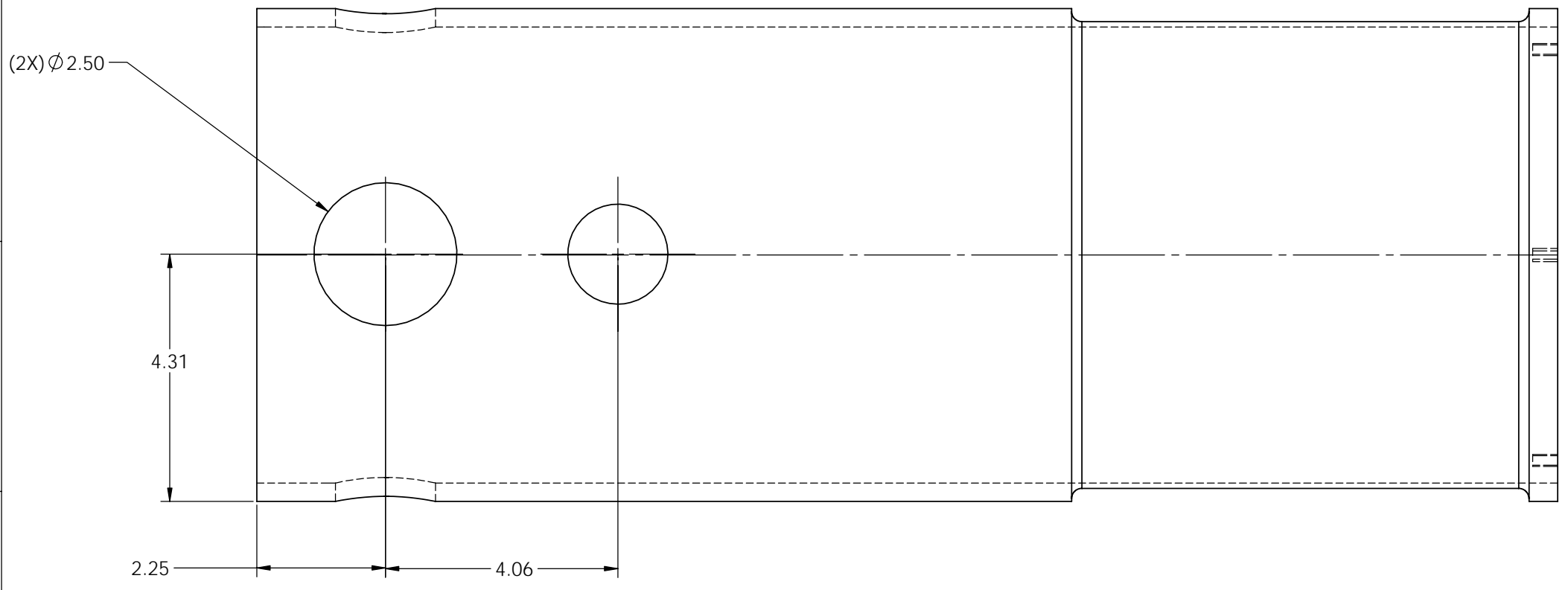
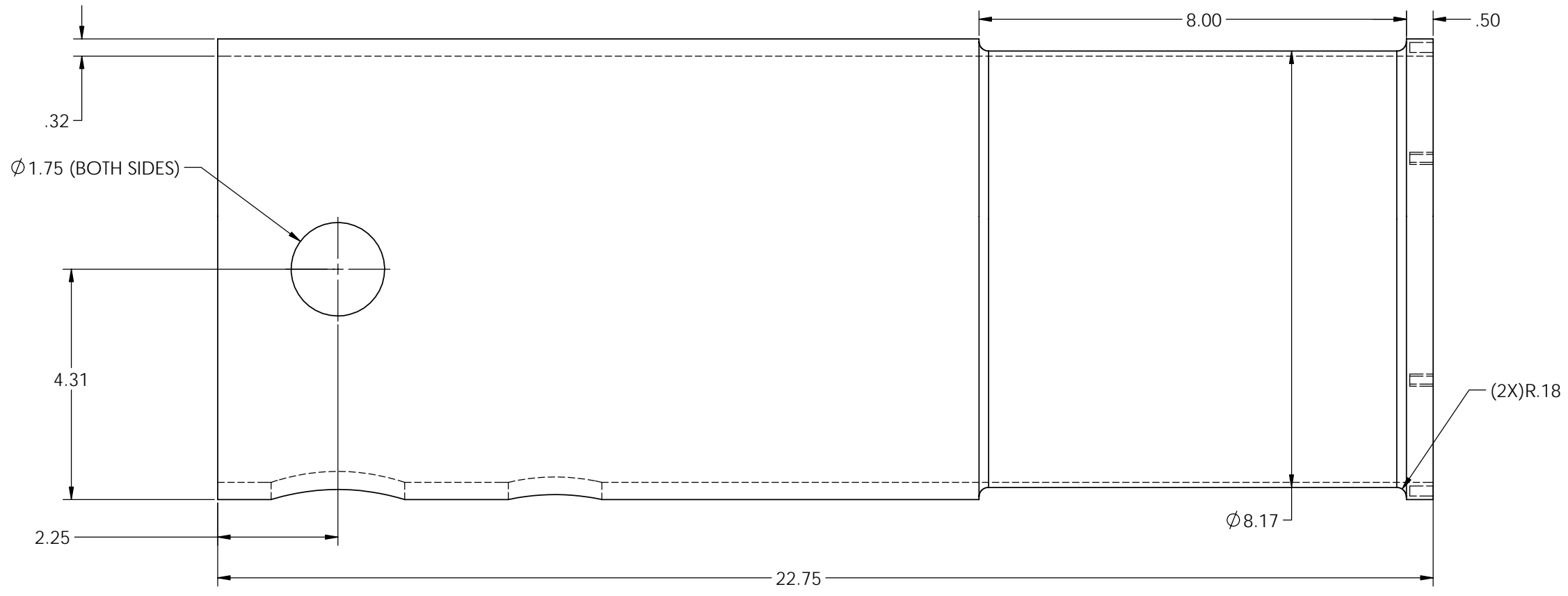

UNLESS OTHERWISE SPECIFIED		DATE	NAME	LIGO CALIFORNIA INSTITUTE OF TECHNOLOGY MASSACHUSETTS INSTITUTE OF TECHNOLOGY
DECIMALS	ANGLES	DRAWN	K. MASON	
.XX ± .06		CHECKED	K. MASON	6/20/03
.XX ± .01	±1	ENG APPR		
.XXX ± .005		MFG APPR		
INTERPRET GEOMETRIC TOLERANCING PER:		C.I.A.		
MATERIAL:	SEE NOTES	COMMENTS:		
FINISH:	SEE NOTES			
DO NOT SCALE DRAWING				

SIZE	DWG. NO.	REV
D	D030245-00-D	

SCALE: 1:1
SHEET 1 OF 1