

REV.	DATE	DCN #	DRAWING TREE #
A	24 JUNE 2004	E040303-00	

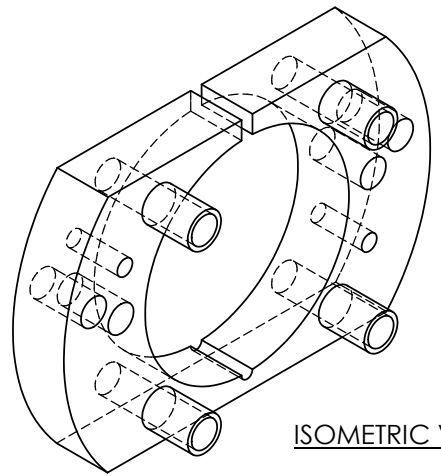

ISOMETRIC VIEW

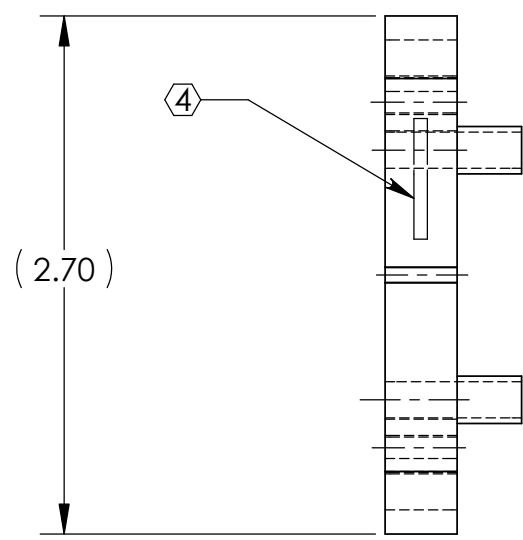

PLAN VIEW

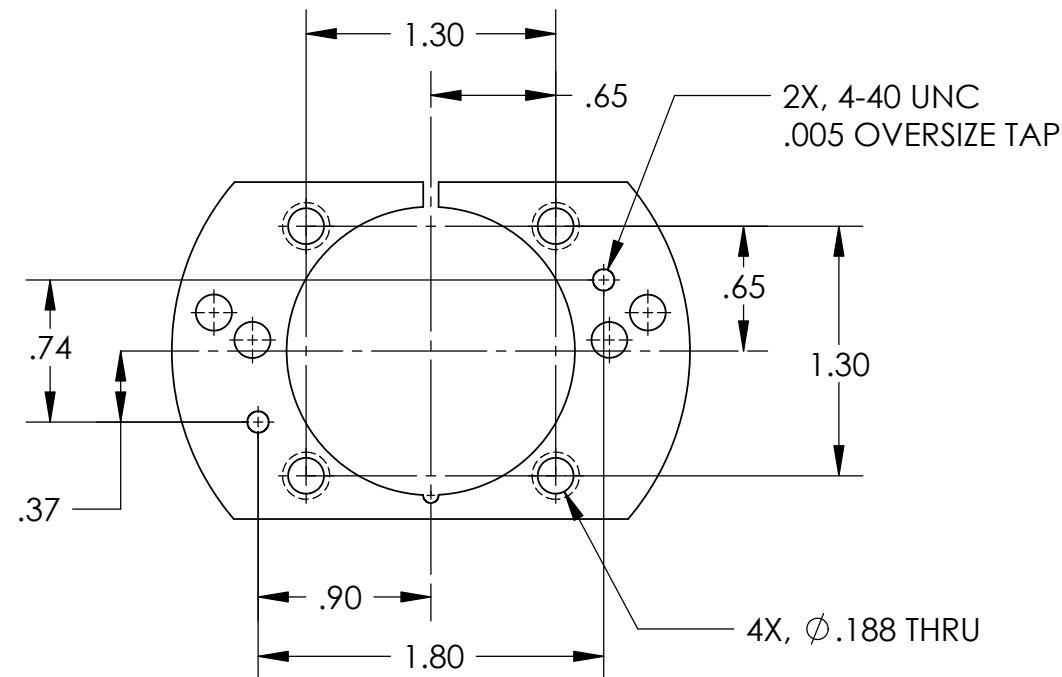

FRONT VIEW

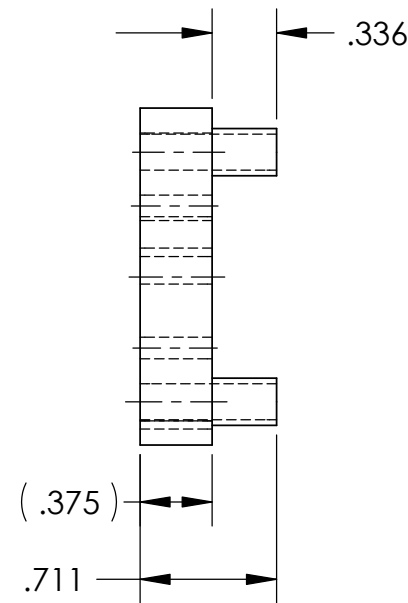

SIDE VIEW

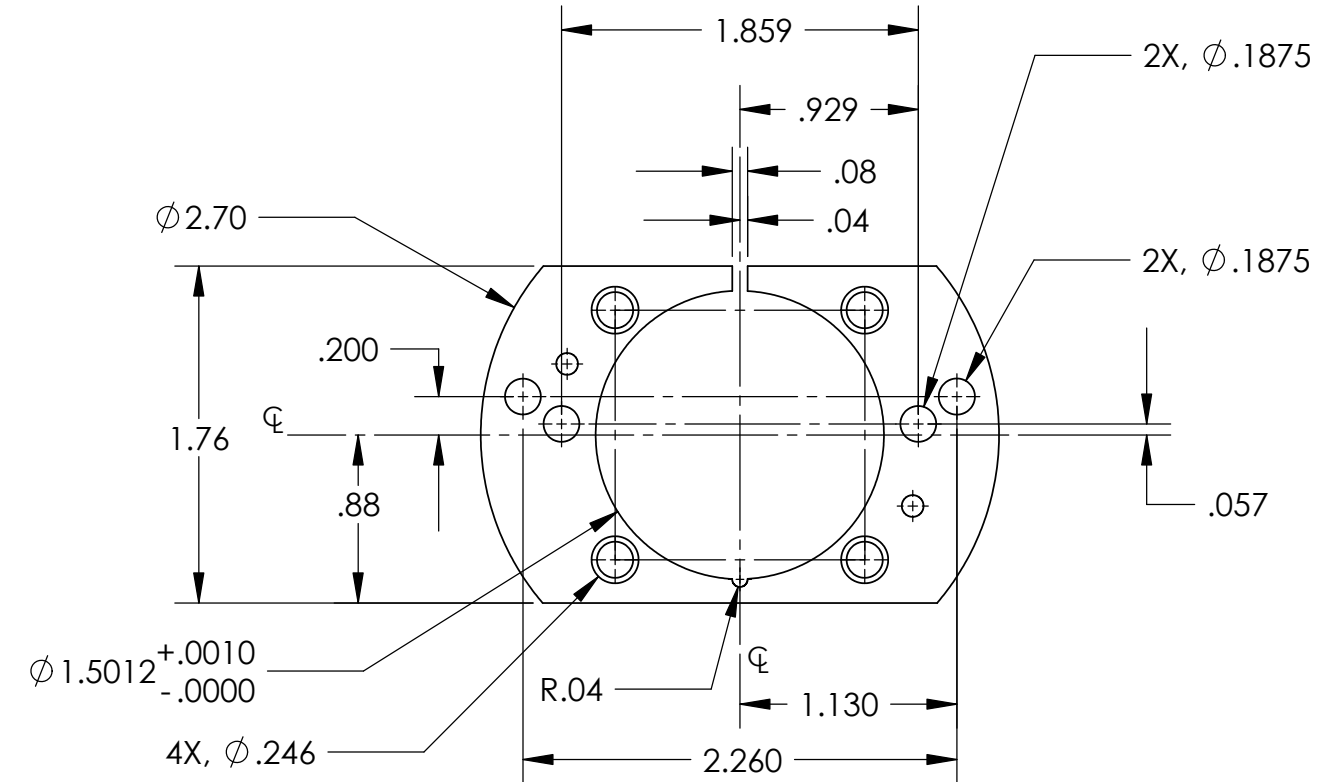

REAR VIEW

D030183\_Coilformer\_Clamp\_OnePiece.step



PARTS LIST			
<p><b>NOTES: (UNLESS OTHERWISE SPECIFIED)</b></p> <p>1. REMOVE ALL SHARP EDGES, R.02 MIN.                  2. DO NOT SCALE FROM DRAWING.                  3. ALL MACHINING FLUIDS SHALL BE WATER SOLUBLE AND FREE OF SULFUR, CHLORINE AND SILICONE, SUCH AS CINCINNATI MILACRON'S CIMTECH 410 (STAINLESS STEEL)</p> <p>④ ENGRAVE DRAWING PART NUMBER ON NOTED SURFACE OF PART AND THEN A THREE DIGIT SERIAL NUMBER. SERIAL NUMBERS START AT 101 FOR THE FIRST PART AND PROCEED CONSECUTIVELY. USE .07" HIGH CHARACTERS.</p> <p>EXAMPLE: D030183- 101</p>		<p>DIMENSIONS ARE IN INCHES</p> <p>TOLERANCES:                  .XX ± 0.01                  .XXX ± 0.005</p> <p>ANGULAR ± 0.5 °</p>	
<p><b>MATERIAL</b> 6061-T6-Al</p>		<p><b>FINISH</b> 32 μinch</p>	
<p><b>DRAWN</b> CIT/RAJ 16/09/03</p>		<p><b>SIZE</b> DWG. NO. D030183</p>	
<p><b>CHECKED</b> LJ / CIT 11/03</p>		<p><b>REV.</b> A</p>	
<p><b>APPROVED</b></p>		<p><b>SCALE:</b> 1:1 <b>PROJECTION:</b> <b>SHEET 1 OF 1</b></p>	