

NOTES: (UNLESS OTHERWISE SPECIFIED)

1. DIMENSIONS IN INCHES.
2. BREAK ALL SHARP EDGES.
3. ALL MACHINING FLUIDS SHALL BE WATER SOLUBLE AND FREE OF SULFUR, CHLORINE AND SILICONE, SUCH AS CINCINNATI MILACRON'S CIMTECH 410 (STAINLESS STEEL.)
4. ETCH OR STAMP THE DRAWING PART NUMBER ON NOTED SURFACE OF PART AND THEN A THREE DIGIT SERIAL NUMBER. SERIAL NUMBERS START AT 001 FOR THE FIRST PART AND PROCEED CONSEQUETIVELY. USE .07" HIGH CHARACTERS. EXAMPLE: D020667-A 001

REV	DATE	DRAWN BY	CHECKED	DCC	DCN/DESCRIPTION
A	9/03	J. ROMIE			E030462/INITIAL RELEASE

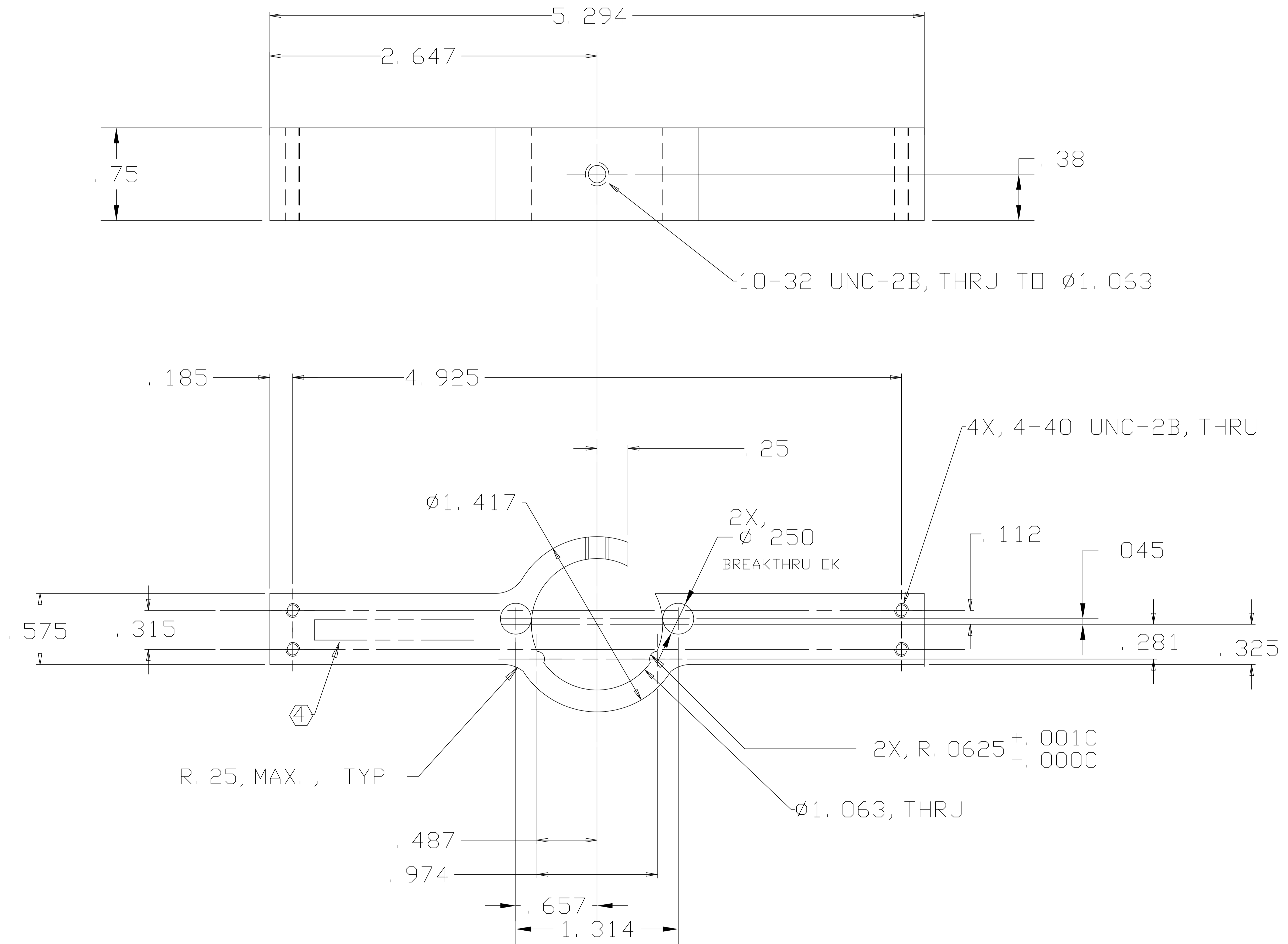

UNLESS OTHERWISE SPECIFIED DIMENSIONS ARE IN INCHES TOLERANCES ARE:		APPROVALS		DATE	LIGO CALIFORNIA INSTITUTE OF TECHNOLOGY MASSACHUSETTS INSTITUTE OF TECHNOLOGY	
FRACTIONS	DECIMALS	DRAWN	J. ROMIE	11/02	TITLE GIN GIN ITM HEAD HOLDER, SIDE	
0. XX=±0.01		CHECKED			DWG NO. D020667	
0. XXX=±0.005					REV A	
ANGLES=±0.5°					SCALE 1/1 SHEET 1 OF 1	
DO NOT SCALE DRAWING						
NEXT ASSEMBLY D020662	MATERIAL 300 SERIES SST					
FILE LOCATION /home/dcc/docs/D020667.pdf	FINISH					