

1. Introduction

A full scale version of the Hydraulic External Pre-Isolator (HEPI) has been installed in a BSC chamber LASTI, the LIGO test facility at MIT. HEPI is a 6 Degree-of-freedom alignment and seismic isolation system which is being developed and tested for possible deployment to the LIGO Livingston Observatory (LLO). This document describes the mechanics of the hydraulic isolation system, the location and coordination of the sensors and actuators, the control topology, and the performance we have achieved to date.

For a description of the hydraulic actuators, please see “Quiet Hydraulic Actuators for Initial LIGO”, LIGO-T020047-00-D .

2. Purpose of the Isolation System

A seismic isolation system is required for the LIGO Livingston Observatory to compensate for large ground motion at the site. Primarily anthropogenic in nature, the ground excitations are large enough that the Observatory is mostly unusable weekdays from about 7 am to 5 pm. The primary effect of this ground motion is to excite the first two horizontal modes of the isolation stack (1.2 Hz and 2.1 Hz, Q of ~ 30). The purpose of the isolation system is to isolate the stack from ground excitations at and around these frequencies, and so reduce the RMS motion of the LIGO test masses. Forthcoming documents by Joe Giaime describe the requirements for an effective isolation system, the original requirements are set forth in the “Initial LIGO Seismic Isolation System Upgrade DRR” LIGO-T020033-02.

It is also our goal to minimize disruption to the interferometer, hence the isolation system is designed to be installed without need for opening the vacuum chambers or realigning the optics. For the BSC chambers, this can be achieved by replacing the coarse and fine actuators with an active isolation frame. For the HAM chambers, the piers must also be replaced.

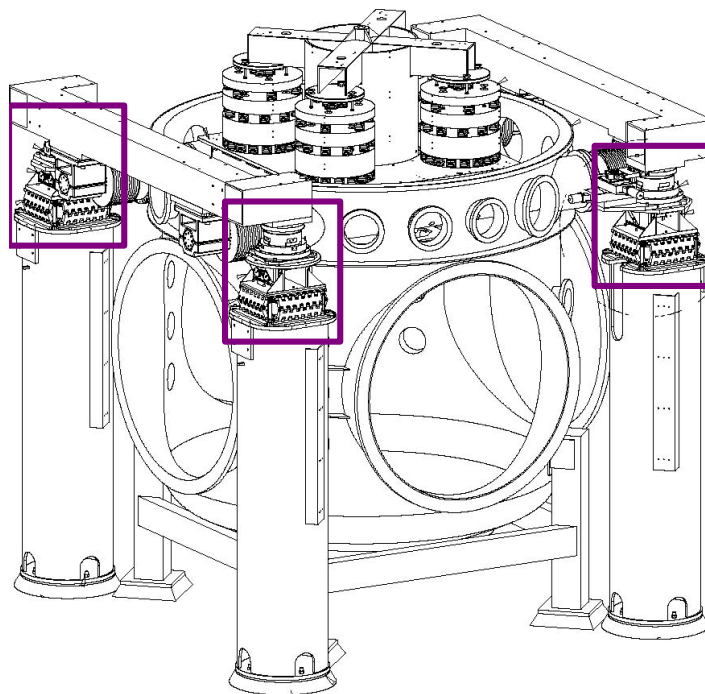

Figure 1. Drawing of the existing BSC chamber. The boxes show the coarse and fine actuators which are to be replaced with external pre-isolators.

3. Design principles for the isolation system

The function of HEPI is based on several basic ideas which we will describe here: the importance of both alignment and isolation, isolation or control in all degrees of freedom, sensor correction for low frequency performance, and static load handling by passive components.

3.1 Importance of both alignment and isolation.

The use of both relative position sensors and inertial sensors for all 6 degrees of freedom of the support table allow both alignment and isolation of the optics. This is critical for maintaining interferometer lock, and allows for useful features such as control reallocation from global interferometer signals.

3.2 Isolation or control in all degrees of freedom.

Due to slight asymmetries, the high Q stack modes are probably not aligned with the arm direction. We expect that it is important to attenuate all three translational drives so as to not excite the stacks in translation or rotation.

3.3 Sensor Correction.

By mounting a single STS-2 seismometer on the floor, we can use sensor correction to achieve isolation of the support table from the microseism to a few Hz.

3.4. Offload springs

The offload springs carry the static load of the system. The springs are arranged in a V at each corner to give vertical and tangential restoring force. The vertical spring rate at each corner is approximately $1.5e6$ N/m, which gives an 8 Hz natural frequency for the vertical support table/offload spring system. Below 8 Hz, the actuators push against the spring rate, and at high frequency they push against the support table inertia.

4. Control of the system.

The support table is controlled in all 6 degrees of freedom, in addition, the two overconstrained degrees of freedom are controlled, and platform is isolated in the three translational degrees of freedom. In this section we will describe how the sensors are blended together, the basis transformation which helps to simplify the control, and various control loops. Not all details of all degrees of freedom will be illustrated, but we hope to give enough detail that the system can be understood.

4.1 Sensor Blending.

Sensor blending can allow improved performance in the controller. We will show how the blending is done, then discuss why we can not get the performance increase we had hoped in the horizontal directions.

Sensor blending is used for the vertical sensors. Each pier has a displacement sensor (Kaman DIT-5200 differential eddy current sensor with a range of ± 1.27 mm) and an inertial geophone sensor (Sercel L-4C 1 Hz passive geophone). Because the noise floor of the geophone becomes dramatically worse at frequencies less than 1 Hz, we use the displacement sensor at low frequencies. The response of the displacement sensors is (assumed to be) well calibrated at the factory, and we rely on that calibration. The geophone sensitivities vary slightly, as do the resonance frequencies and Q's. We assume that the geophone sensitivities are not changing with time (seems to be true, and the temp at the sites is better controlled than at LASTI). Even so, we

use very conservative blending, as that gives better performance over the whole band, when we are not limited by noise in the sensor. This means that the relative slope between the two sensors is nearly $1/f$ for almost a factor of 10 in frequency both above and below the blend frequency. Conservative blending means that even if the gains change slightly, the vector sum of the two sensors does not change by large amounts.

The blend is done in several steps. First, choose a blending frequency. For the vertical sensors on HEPI, this is currently 0.8 Hz. Next, multiply the two sensor response so that the relative phase between them near the blend frequency is nearly 90 degrees. These filters also attenuate the sensor signal at out-of-band frequencies (additional attenuation at high frequencies for the displacement sensor and at low frequencies for the geophone). In addition, the geophone filter is tuned to remove the unit-to-unit differences in the geophones. Third, give additional gain to one sensor (the geophone) so that the sensitivities of the filtered geophone and filtered displacement sensor match at the blend frequency (0.8 Hz)

The filters used are shown below in figure 2 a, b, and c

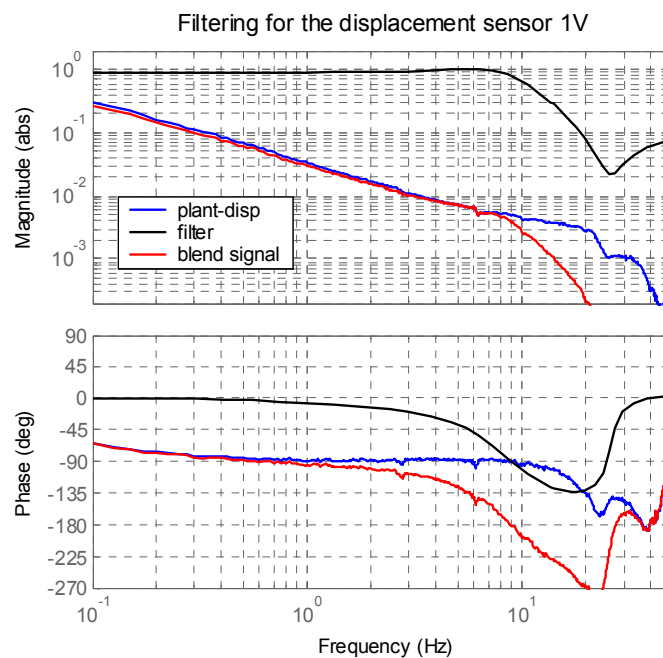

Figure 2a. Open loop Bode plots of the blend filter for the vertical displacement sensor on pier 1. The blue curve shows response of the displacement sensor (motion calibrated into mm) to drive from the pier 1 vertical actuator (drive in dspace units). The blend filter is shown in black. It is a simple 2 pole – 2 zero filter (derated elliptic filter) to attenuate the displacement sensor signal above 10 Hz. The red curve is the filtered displacement sensor.

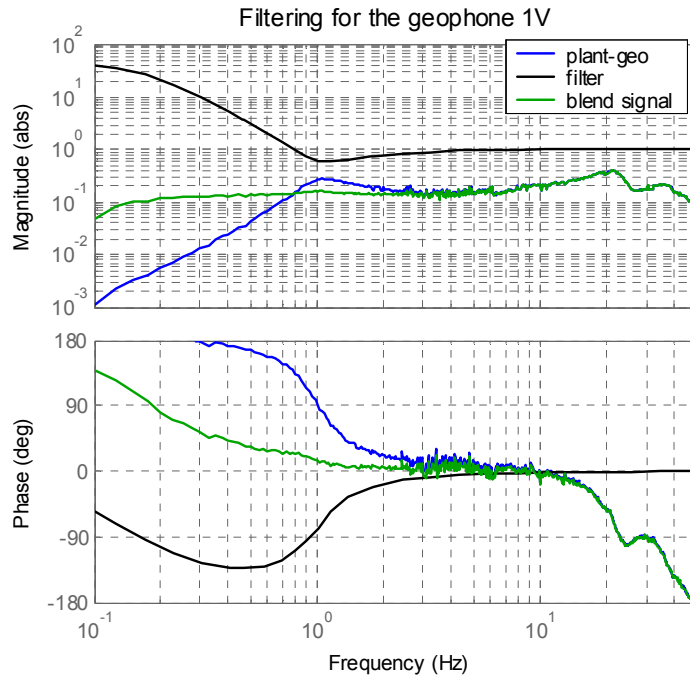

Figure 2b. Open loop Bode plots of the blend filter for the vertical geophone on pier 1. The blue curve shows response of the geophone (motion in dspace units) to drive from the pier 1 vertical actuator (drive in dspace units). The blend filter is shown in black. It is an AC coupled 2 pole – 2 zero filter which makes the geophone appear to be a critically damped instrument with poles at 0.15 Hz. The green curve is the filtered geophone response.

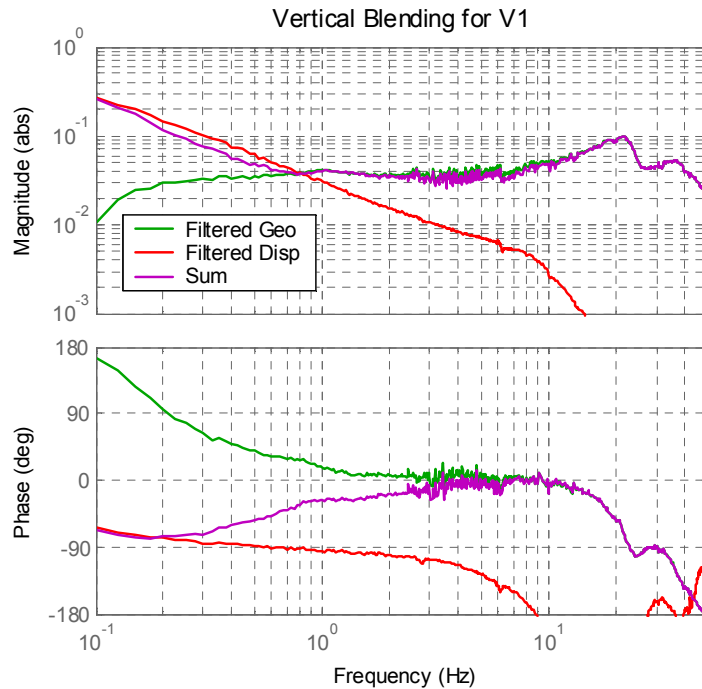

Figure 2c. Open loop Bode plots of the blended supersensor on pier 1. The red curve is the filtered displacement sensor from subplot a. The green curve is the filtered geophone which has been multiplied by enough gain so that the magnitude of the two filtered sensors matches at the blend frequency of 0.8 Hz. The supersensor response, shown in magenta, is the vector sum of the two.

Blending has the distinct advantage of using local inertial sensors for the feedback signal. This allows one to take full advantage of resonant gain bumps in the control for improved isolation and doesn't require sensor blending. However, we will see in the next section that the plant dynamics often limit the use of the inertial sensors. Currently, the only direction which uses these blended sensors in the z direction of the vertical loops. The pitch, roll, and vertical overconstrained directions only use displacement sensors.

4.2 Coordinate basis for control

The controllers for the system are 8 SISO controllers applied to the plant after the plant has been projected into a new basis, derived from frequency independent linear combinations of sensors and actuators. The original basis is called the “pier basis,” and corresponds to the set of 8 actuators and 16 sensors. The new basis is called the “coordinate basis,” and corresponds to motions in the beam direction “x”, transverse motions “y”, vertical motions “z”, the three corresponding rotations, “pitch”, “roll”, and “yaw”. There are two overconstrained degrees of freedom corresponding to situations when the actuators are trying to bend the structure. These are the “overconstrained vertical (ocv)” and “overconstrained horizontal (och)” modes (sometimes called the “pringle modes”). This basis is more diagonal, and (arguably) easier to understand.

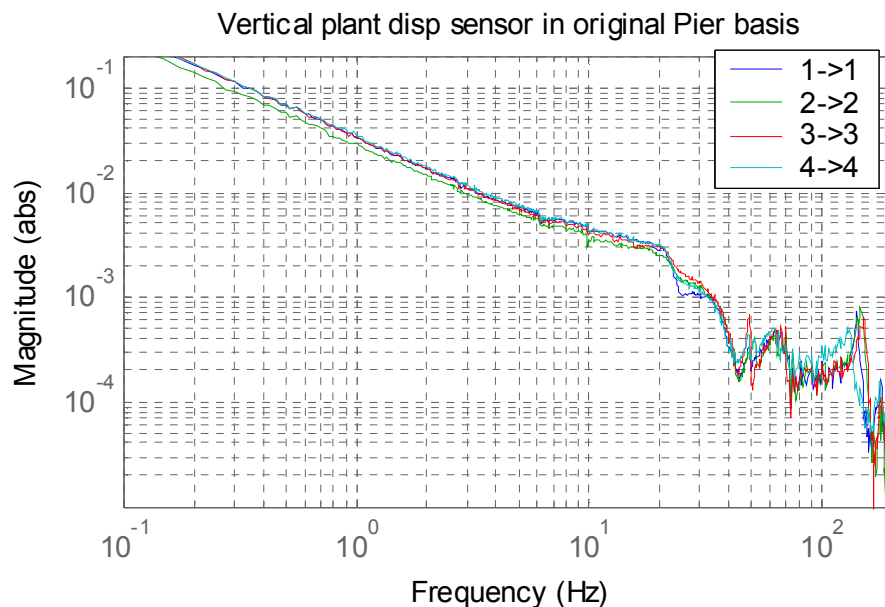

Figure 3a. Bode magnitude of the open-loop vertical plant, showing the “on-diagonal” response of the vertical displacement sensors (in mm) to their respective vertical actuators (in dspace drive units). Notice that the four corner are almost identical (good), and that they show poles at 20 Hz and again around 30 Hz, since the vertical and tilt modes are at different frequencies.

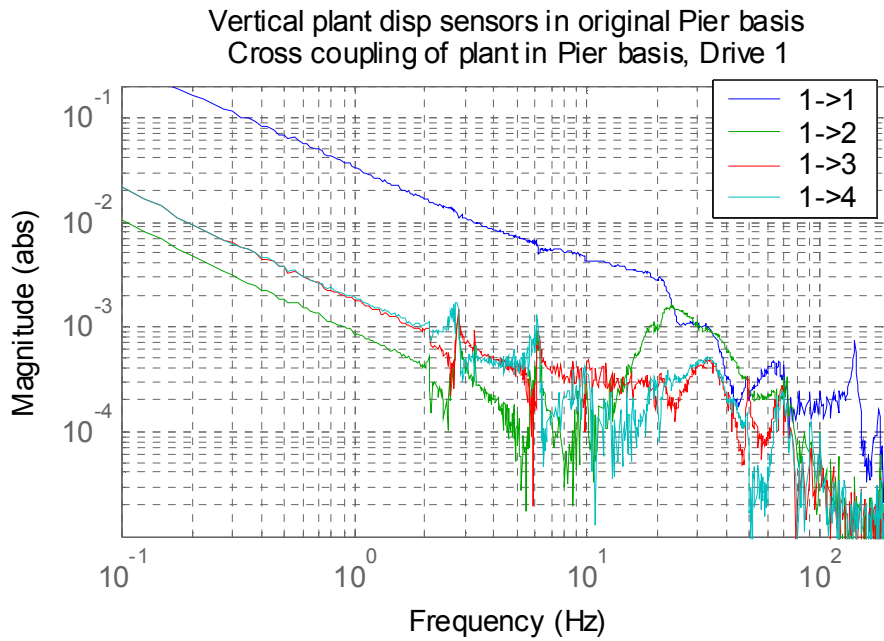

Figure 3b. Bode magnitude of the open-loop vertical plant, showing selected “off-diagonal” response of the vertical displacement sensors (in mm) to drive at the pier 1 vertical actuator (in dspace drive units). The blue curve (on top) is the collocated sensor at pier 1. At 25 Hz, notice that the response at pier 2 is larger than at pier 1. The other drives are similar. This cross-coupling would make SISO controllers difficult. It is interesting to note that at low frequencies, the off diagonal terms are much less than would be expected for a system which only has compliance at the table/ pier interface (which would give 1/3 of the on diagonal term). This system has compliance in the piers and the support table. At a 15 Hz upper unity gain frequency, one could probably run SISO control at the corners.

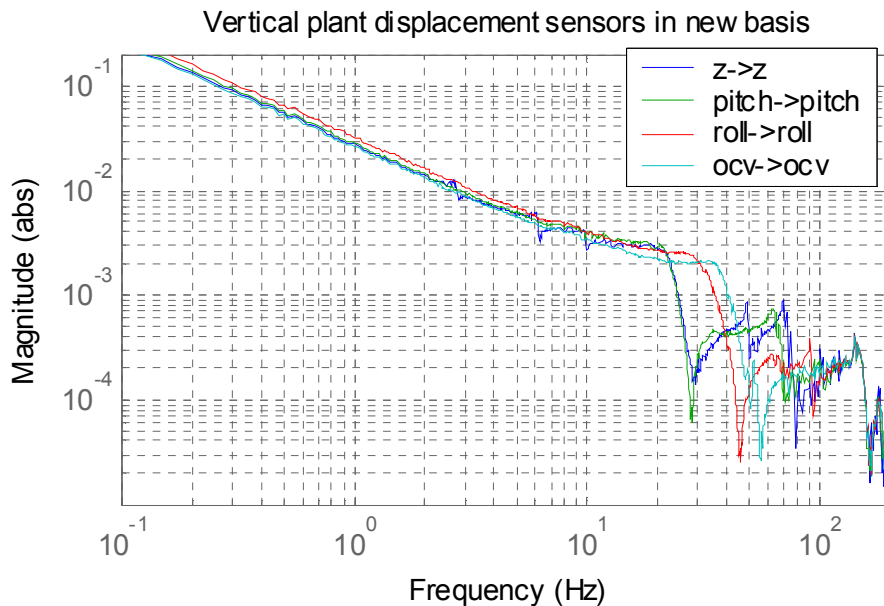

Figure 4a. Bode magnitude of the open-loop vertical plant in the “coordinate basis”, showing the “on-diagonal” response of the vertical displacement sensors (in mm) to their respective vertical drives (in dspace drive units). The response in the new bases are similar at low frequencies, but each have a single, characteristic roll-off frequency. Note that stack modes are clearly visible in the blue, z, curve, but not in the red or green rotation directions Upper unity gain frequencies above 10 Hz are difficult, and above 20 Hz are likely not robust (foolhardy).

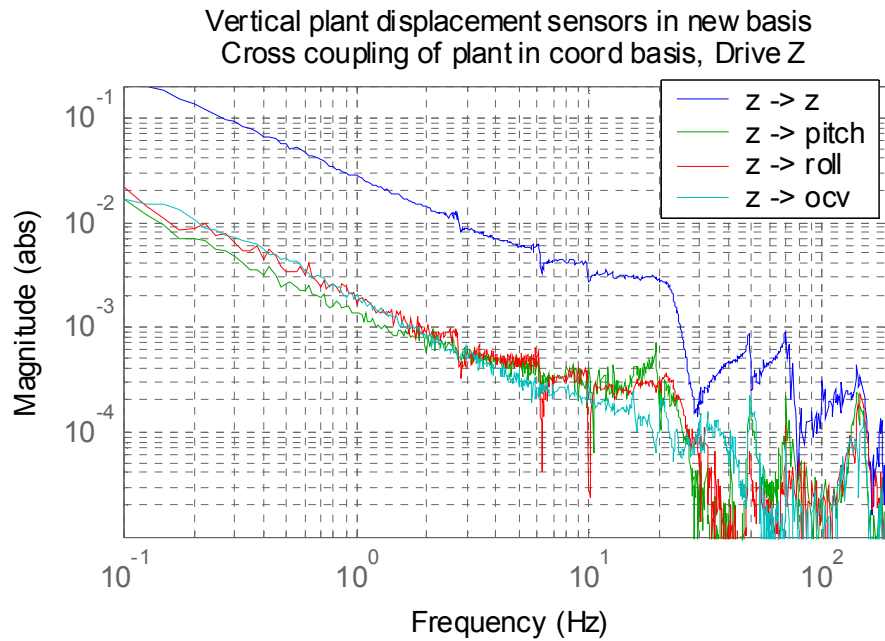

Figure 4b. Bode magnitude of the open-loop vertical plant in the coordinate basis, showing selected “off-diagonal” response of the vertical displacement sensors (in mm) to drive in the z direction (in dspace drive units). The blue curve (on top) is the z to z transfer function, which is always above, and usually well above, the off-diagonal elements. The other directions are similar.

The matrix used to generate the new basis is quite simple. The Matlab code used to generate the basis transformations vertical direction and the horizontal direction, are shown below (slightly edited for slightly more clarity):

```
% vertical basis transformation
z    = [1  1  1  1]';   %V1 V2 V3 V4
pitch = [1  1 -1 -1]';
roll  = [1 -1 -1  1]';
ocv   = [1 -1  1 -1]'; %pringle

% gv normalizes the vertical actuator responses
drive_matrix = diag(gv)*[z,pitch,roll,ocv];
sens_matrix  = inv([z,pitch,roll,ocv]);

% horizontal basis transformation - note that horizontal actuators alternate direction
x    = [-1  1  1 -1]';
y    = [ 1  1 -1 -1]';
yaw  = [ 1 -1  1 -1]';
och  = [ 1  1  1  1]';

% gh normalizes the horizontal actuator responses
horz_drive_matrix = diag(gh)*[x,y,yaw,och];
horz_sens_matrix  = inv([x,y,yaw,och]);
```

4.3 Control loop in the Z direction

The z direction can be controlled with either corrected displacement sensors or with corrected supersensors. Figure 5, below, shows the control used for the supersensor case.

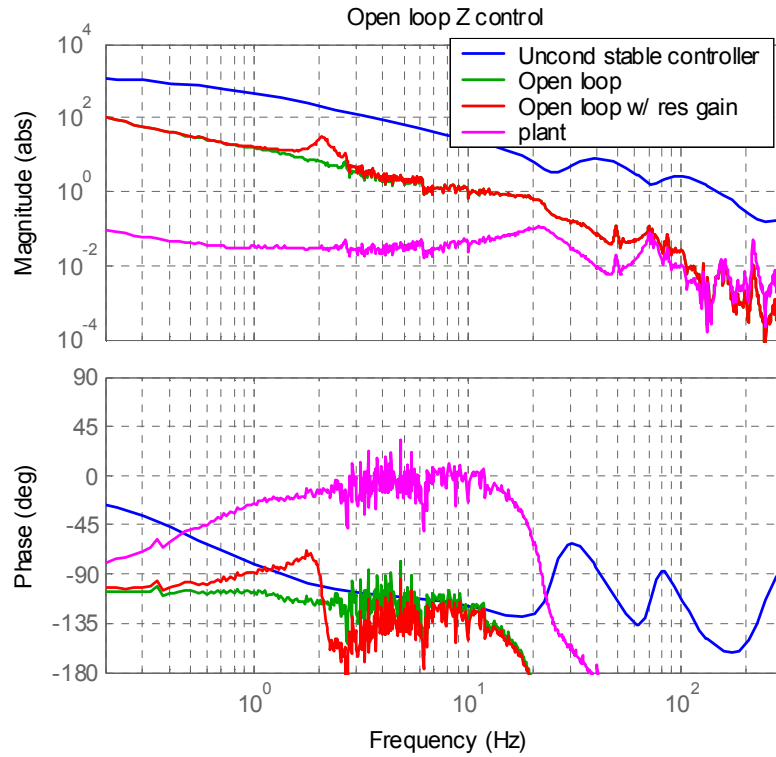

Figure 5. Open loop Bode plot of the control in the coordinate z direction. The magenta curve is the response of the coordinate z plant from drive to supersensor (mm/dspace drive). The blue curve is the basic controller, which is unconditionally stable (dspace out/ dspace-mm input). The green curve is open loop system, ie the product of the plant and control. The upper unity gain freq is 10 Hz. The red curve shows the impact of adding a resonant gain peak at 2.1 Hz. This loop is conditionally stable, so the resonant gain is activated only after the basic control is running. Note the simplicity of the control law.

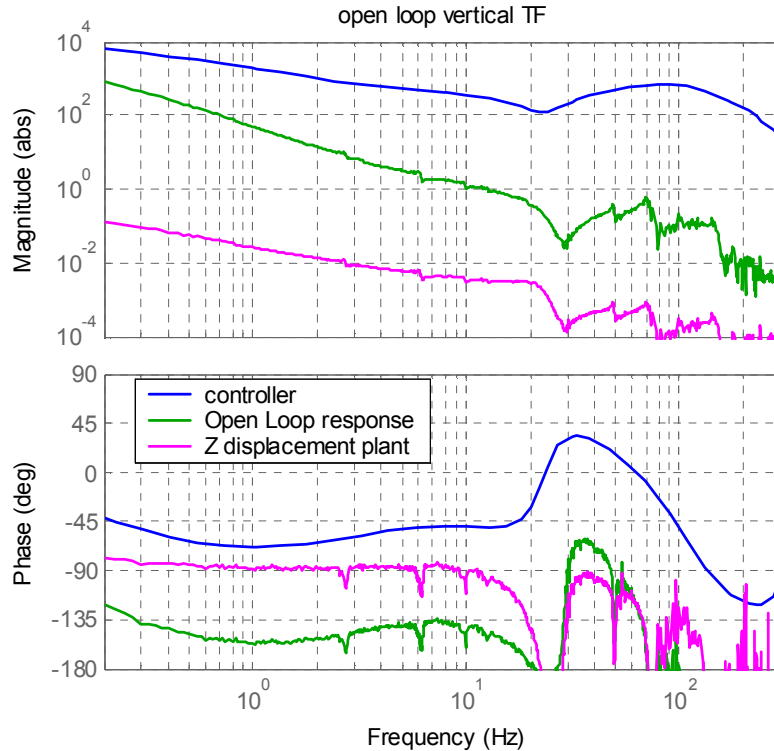

Figure 6. Open loop Bode plot of the control in the coordinate z direction with only displacement sensors. The magenta curve is the response of the coordinate z plant from drive to displacement sensor (mm/dspace drive). The blue curve is the basic controller, which is unconditionally stable (dspace out/ dspace-mm input). The green curve is open loop system, ie the product of the plant and control. The upper unity gain freq is 10 Hz. Isolation is achieved with sensor correction. Note that this controller is even more simple than the supersensor control shown in figure 5.

4.4 Control loop in rotational directions

The three rotation directions are presently controlled with displacement sensors only and do not use sensor correction. This means that the pitch, yaw, and roll of the platform should be follow the ground motion. Even so, having these loops running provides several advantages, namely

- 1) Reduction of cross coupling – imperfectly balanced translation drive would otherwise result in rotation.
- 2) Stable, calibrated alignment – with servo control, angular command inputs referenced to the sensor calibration and stability, not that of the actuators.
- 3) Reduction of actuator noise – closing all degrees of freedom reduces the effect of forces on the support table, such as actuator noise.

The rotation loops show almost no coupling to the stack modes. The pitch control is an exemplar of these loops, and is shown below in figure 7.

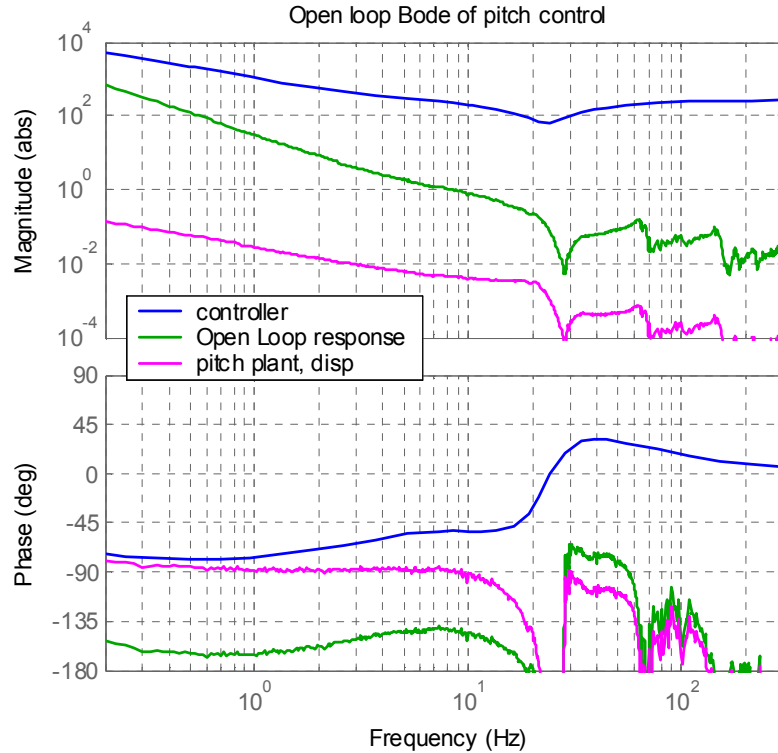

Figure 7. Open loop Bode plot of the control in the coordinate pitch direction with only displacement sensors. The magenta curve is the response of the coordinate pitch plant from drive to displacement sensor (mm/dspace drive). The blue curve is the basic controller, which is unconditionally stable (dspace out/ dspace-mm input). The green curve is open loop system, ie the product of the plant and control. The upper unity gain freq is 10 Hz. Isolation is achieved with sensor correction. Note that this controller is extremely simple.

A quick summary of the loops is given below

<u>direction</u>	<u>sensor</u>	<u>upper unity gain</u>
z	corrected supersensor	10 Hz
pitch	displacement sensor	8 Hz
roll	displacement sensor	8 Hz
ocv	displacement sensor	12 Hz
x	corrected disp. sensor	20 Hz
y	corrected disp. sensor	20 Hz
yaw	displacement sensor	8 Hz
och	displacement sensor	7 Hz

Sensor correction in the horizontal translational degrees of freedom was not used because the plant was much easier to control using only the displacement sensors. Figure 8, below compares the open loop plant in the x direction measured by seen by the supersensors to that measured by the displacement sensors only. It is clear that the displacement sensor only loop is much more simple to control.

4.5 Control loop in the X and Y directions

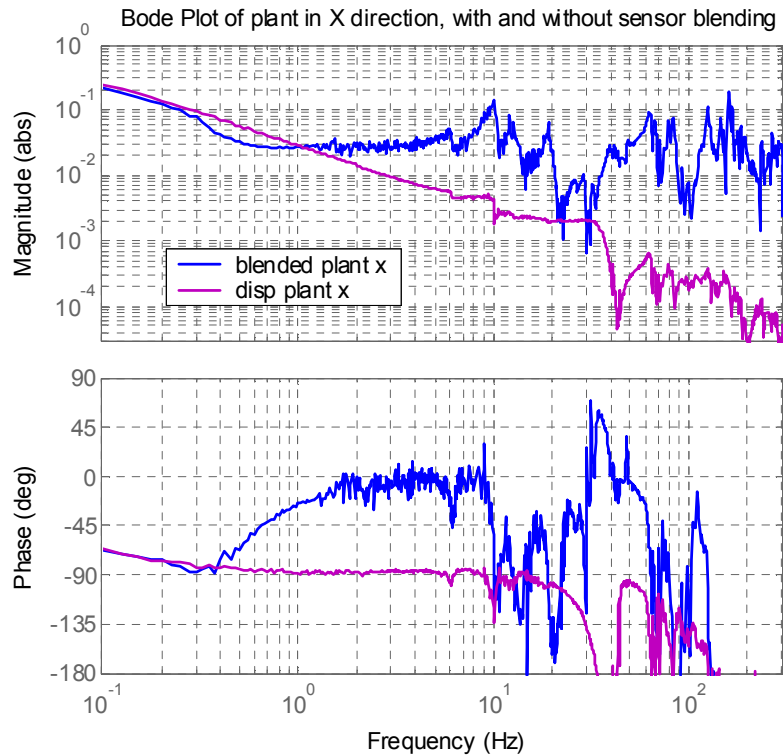

Figure 8. Comparison of the open loop plant response in the coordinate x direction measured by the supersensor (blue, mm/dspace drive) and the displacement sensors (magenta, mm/dspace drive). Control of the supersensor is more difficult, due to the coupling of the stack modes at 10, 12 and 20 Hz, the 24 Hz zero from the sway mode of the pier, and other mechanical modes above 60 Hz.

The horizontal translations are controlled using only displacement sensors, due the relative simplicity of that solution. The x and y controls are virtually identical, the x control is shown below in figure 9.

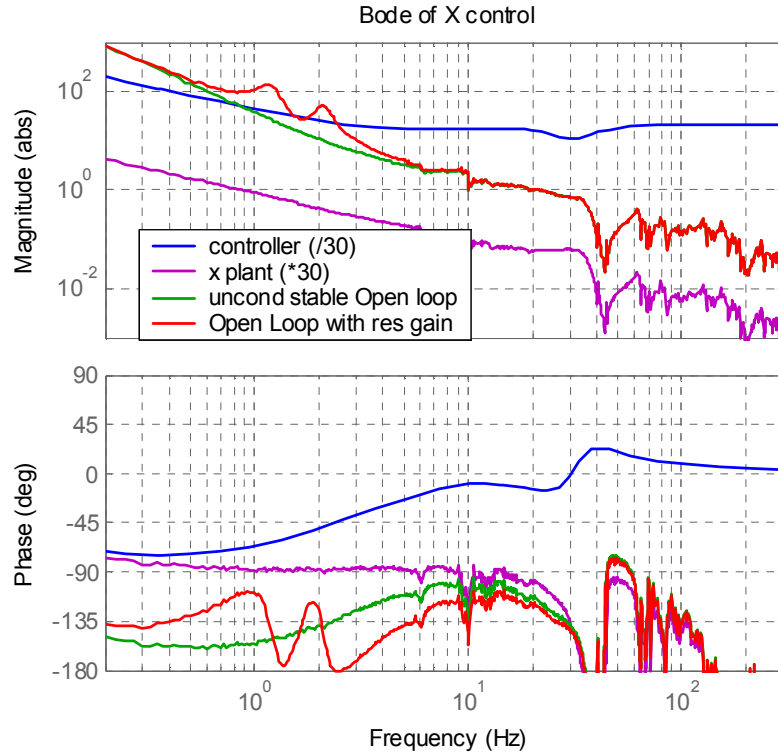

Figure 9. Open loop Bode plot of the control in the coordinate x direction. The magenta curve is the response of the coordinate z plant from drive to displacement sensor (mm/dspace drive). The blue curve is the basic controller, which is unconditionally stable (dspace out/ dspace-mm input). The green curve is open loop system, ie the product of the plant and control. The upper unity gain freq is 20 Hz. The red curve shows the impact of adding a resonant gain peak at 1.2 and 2.1 Hz. This loop is conditionally stable, so that feature is turned on after the basic control is running. Note the simplicity of the control law. To superimpose the plant and controller, the controller has been divided by 30, and the plant multiplied by 30.

4.6 Control diagram

The control is implemented with a dSPACE realtime controller. The dSPACE hardware and software interface with Matlab and Simulink. The control design is done in Matlab and assembled and compiled from a Simulink diagram.

A typical control diagram is shown below.

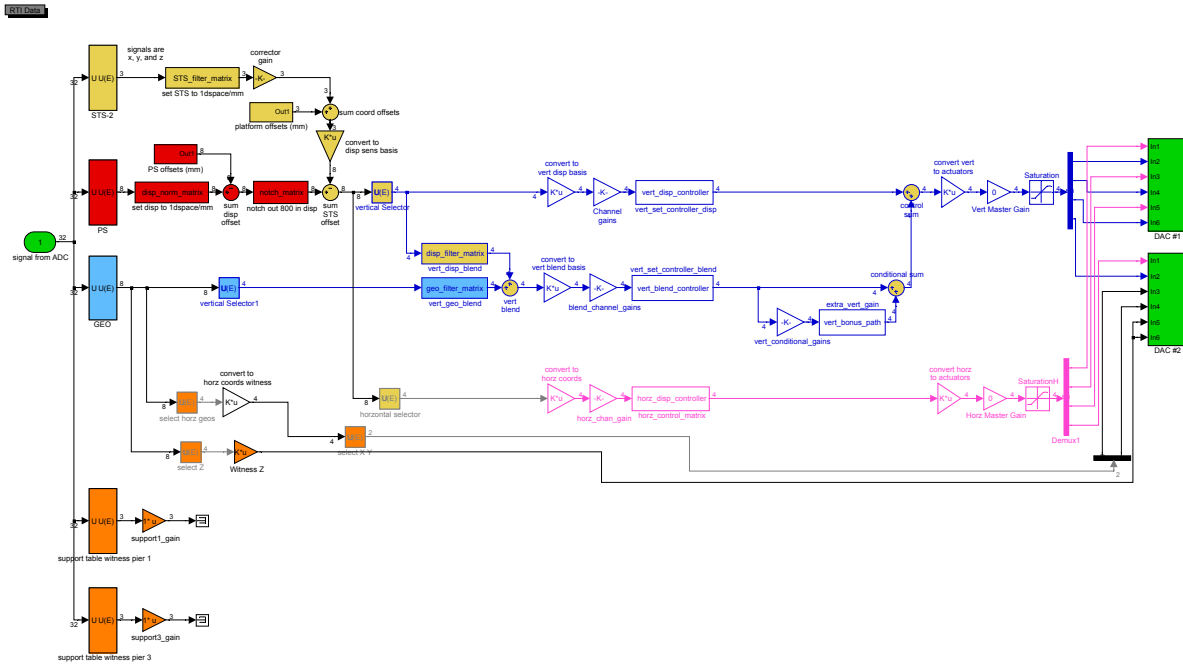

Figure 10. Control diagram for the HEPI system. This is a vectorized control diagram, and the number of parallel signal traveling in a connection can be read from the little number associated with each line. The controllers are all block diagonal. Yellow boxes are STS-2 data and corrections, red are from the displacement sensors, and light blue are for the geophones. The dark blue boxes are the controls for the vertical channels, and the magenta are for the horizontal channels. Witness channels are shown in orange in the lower left. Green boxes represent connections to the input and output hardware.

4.7 Sensor correction

The sensor correction is straightforward to implement. The signal from the displacement sensors in the diagram has the effect of the analog whitening filter removed and then calibrated so that 1 dspace count is 1 mm of displacement. The STS-2 signal into the dSPACE is also calibrated into the same units – mm of floor displacement, by use of an AC coupled integrator. The two AC coupling poles are at 10 mHz which means that the phase at the 0.15 Hz (the microseism), however, at the sites the tilt noise should be substantially smaller (based on work by Joe Giaime and PEPI), so the AC cutoff can be moved down, which will improve the matching at .15 Hz. Also, Wensheng Hua at Stanford has been working to implement FIR filters with better performance in terms of good phase at .15 Hz and good rejection of low freq signal. A pole zero pair is used at 20-60 Hz to improve the phase matching with the seismometer from 3 to 5 Hz.

The integrator is shown in figure 11.

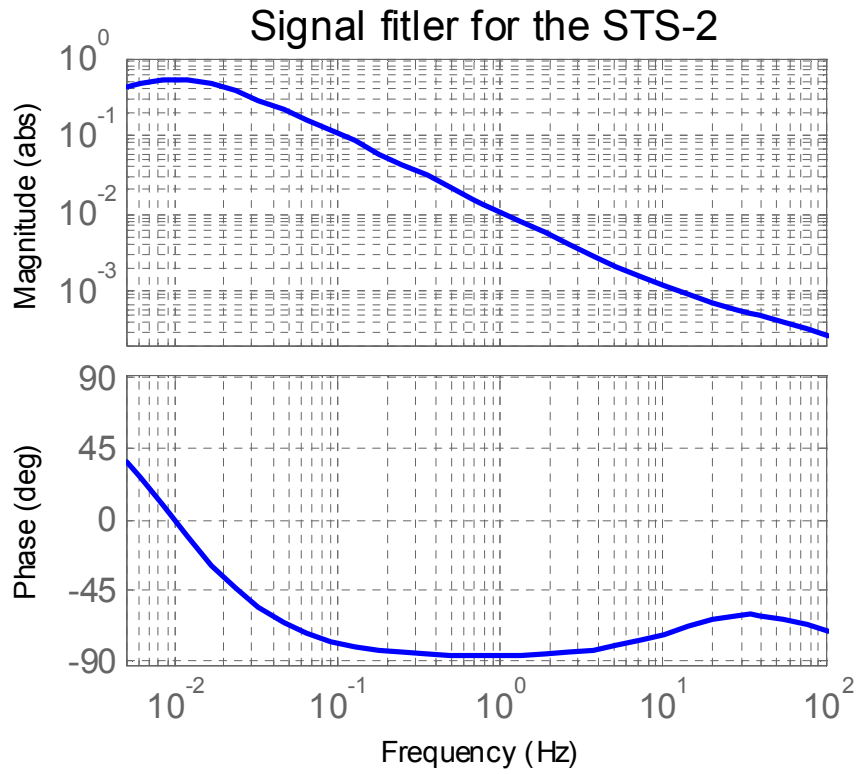

Figure 11. Signal filter for the STS-2 channels. The input to the filter is the STS-2 data input into dspace. The filter output corresponds to mm of ground displacement (from the microseism to about 10 Hz). This signal is subtracted from the displacement sensors, which is equivalent to commanding the platform relative motions equal and opposite of ground motions.

5.0 Performance

The goal of this experiment is to get good performance around the problematic horizontal stack modes at 1.2 and 2.1 Hz. Here we show performance from the ground to the support table at the base of the stack.

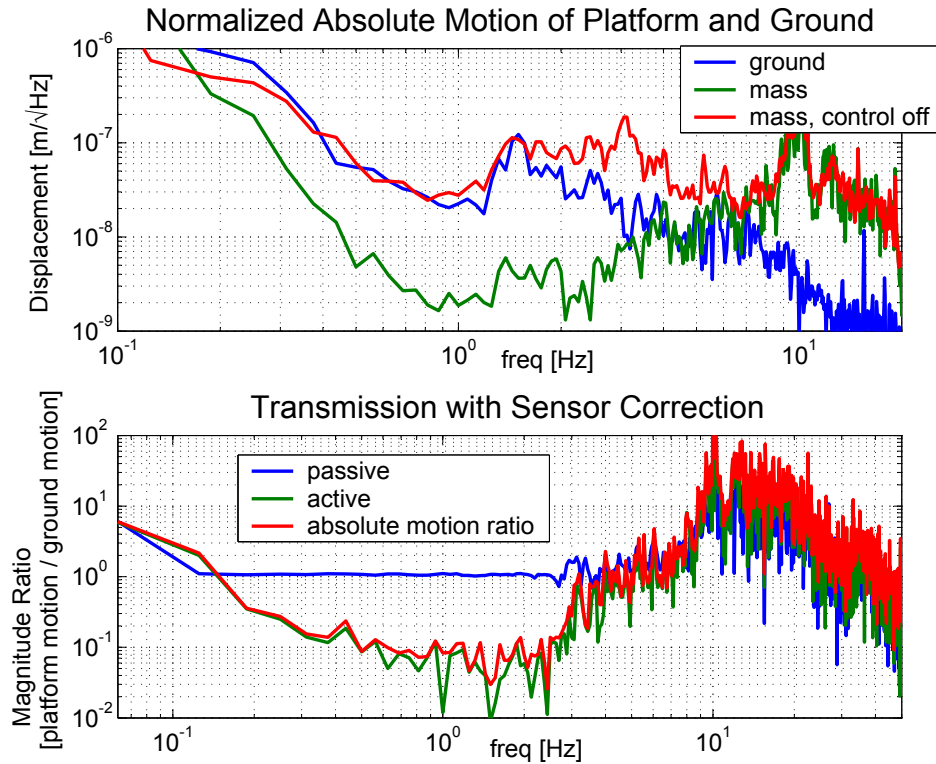

Figure 12. **Performance in the X direction**, measured from the ground to the support table on 4/11/03. The top plot shows the amplitude spectral density (ASD) of the motion of the ground (blue), the motion of the support table with the control off (red), and the motion of the table with control on (green). The table motion is larger than the ground motion above 10 Hz, regardless of the control. The lower plot shows the transmission (relative amplitude of **correlated** motion) with the control off (blue) and on (green). The transmission from 0.3 to 2.5 Hz is quite good. The red curve is the ratio of the ASD's of ground and support table (includes **uncorrelated** motion). There is good agreement, indicating the performance limit is gain and sensor correction matching, not noise. Note that the motion of the support table around 1 Hz is about 2e-9 m/rtHz.

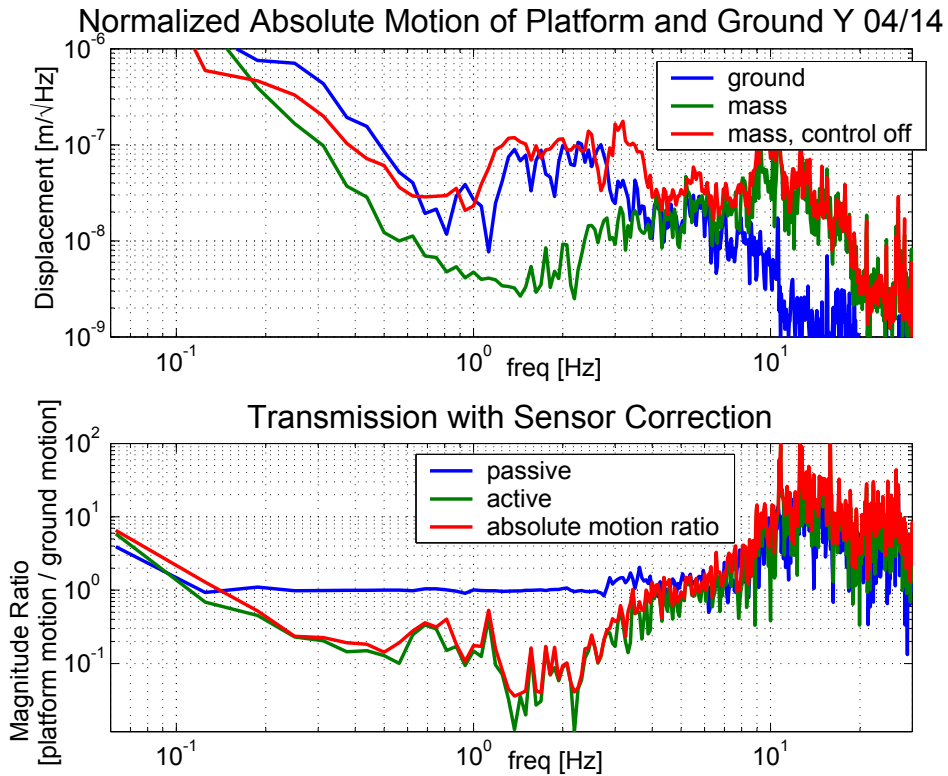

Figure 13. **Performance in the Y direction**, measured from the ground to the support table on 4/11/03. The figure is the same format as the X performance figure above. There is good performance from .4 to 2.5 Hz. Below .4 Hz the performance may be suffering from tilt. Above that frequency, the performance limit is gain and sensor correction matching.

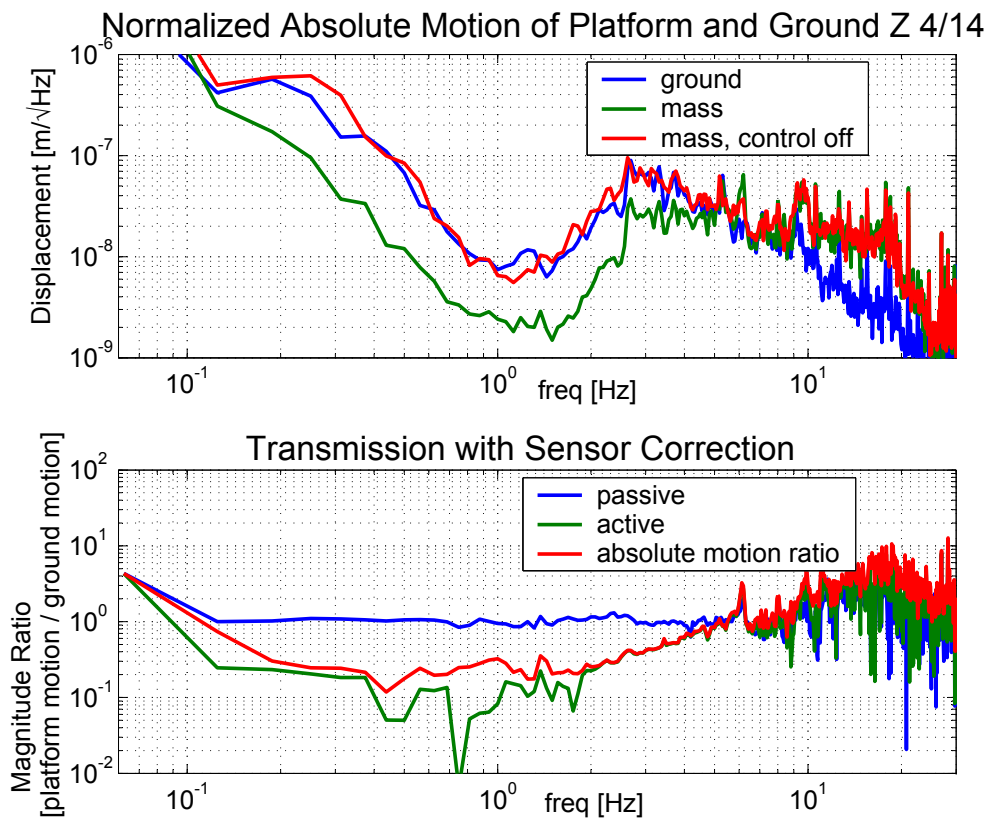

Figure 14. **Performance in the Z direction**, measured from the ground to the support table on 4/11/03. The figure is the same format as the X performance figure above. There is good performance from the microseism to 2 Hz. The resonant gain stage was not activated for this measurement. The performance limit above 2 Hz is gain and sensor correction matching, not noise, so resonant gain could help.

As we can see in figure 12-14, the performance of the hydraulic system is good, and should meet the requirements.