

D1002364_ALIGO_AOS_D0900623_Faraday Isolator Beam Dump Assy, PART PDM REV: X-014, DRAWING PDM REV: X-008

REV.	DATE	DCN #	DRAWING TREE #
v1	07 OCT 2010	E1000563	
v2	17 DEC 2010	E1000563	
v3	20 SEP 2012	E1000563	

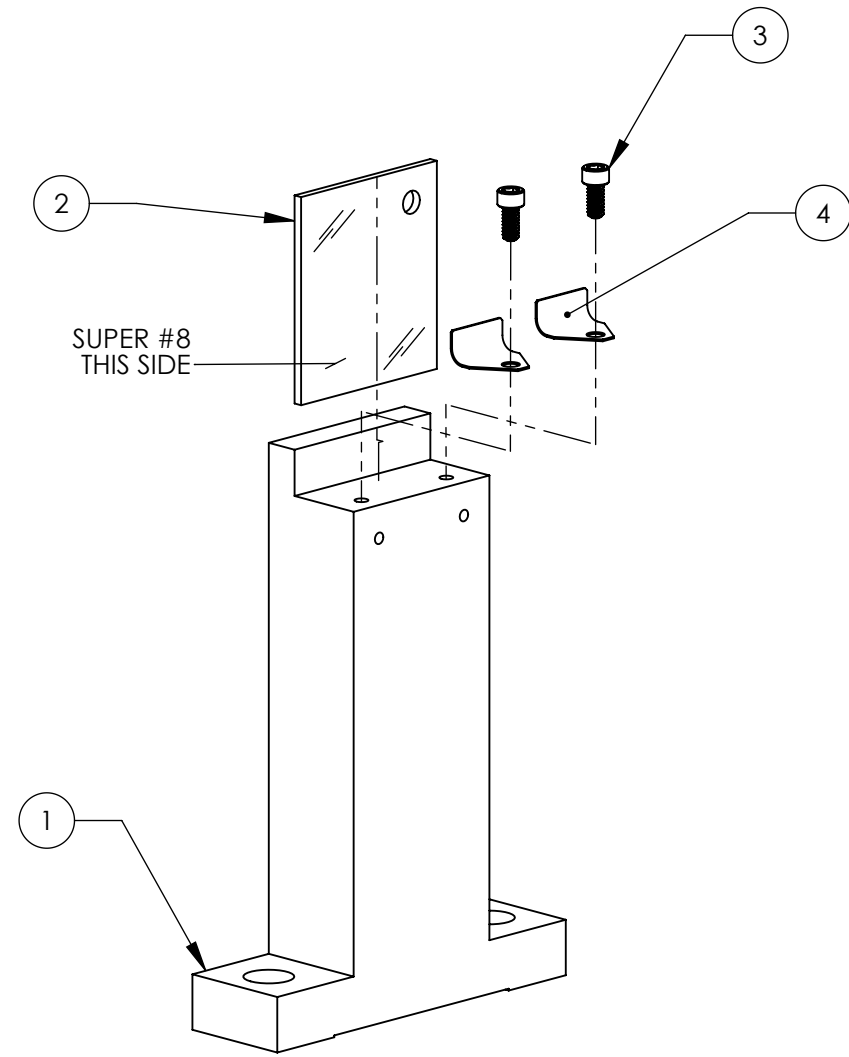

ITEM NO.	PART NUMBER	DESCRIPTION	MATERIAL	REQ	SPARE	TOTAL
4	D1100027	CLIP	304 SSTL	2		2
3	92200A076	Head Cap Screw 300 Series SS, 2-56 Thrd, 3/16" Length, MS 16995-1	300 SSTL	2		2
2	D1002363	FARADAY ISOLATOR BEAM DUMP	18 GA A424 TYPE 1 STEEL	1		1
1	D1002362	FARADAY ISOLATOR BEAM DUMP MOUNT	6061-T6 Al	1		1

PARTS LIST

DIMENSIONS ARE IN		NOTES AND TOLERANCES: (UNLESS OTHERWISE SPECIFIED)		CALIFORNIA INSTITUTE OF TECHNOLOGY MASSACHUSETTS INSTITUTE OF TECHNOLOGY		PART NAME	
TOLERANCES:		1. INTERPRET DRAWING PER ASME Y14.5-1994. 2. REMOVE ALL SHARP EDGES, R.02 MIN. 3. DO NOT SCALE FROM DRAWING. 4. ALL MACHINING FLUIDS MUST BE FULLY SYNTHETIC, FULLY WATER SOLUBLE AND FREE OF SULFUR, SILICONE, AND CHLORINE.		SYSTEM		FARADAY ISOLATOR BEAM DUMP ASSY	
.XX ±		MATERIAL		SUB-SYSTEM		DESIGNER	
.XXX ±		N/A		NEXT ASSY		DRAFTER	
ANGULAR ± °		FINISH		D0900623		CHECKER	
		N/A μinch				APPROVAL	
						SIZE DWG. NO. B D1002364	
						MRUIZ 09 AUG 2010 SCALE: 1:1 PROJECTION:	
						REV. v3	
						SHEET 1 OF 1	