

NOTES: (UNLESS OTHERWISE SPECIFIED)

REV.	DATE	DCN #	DRAWING TREE #
A	2/9/2003		

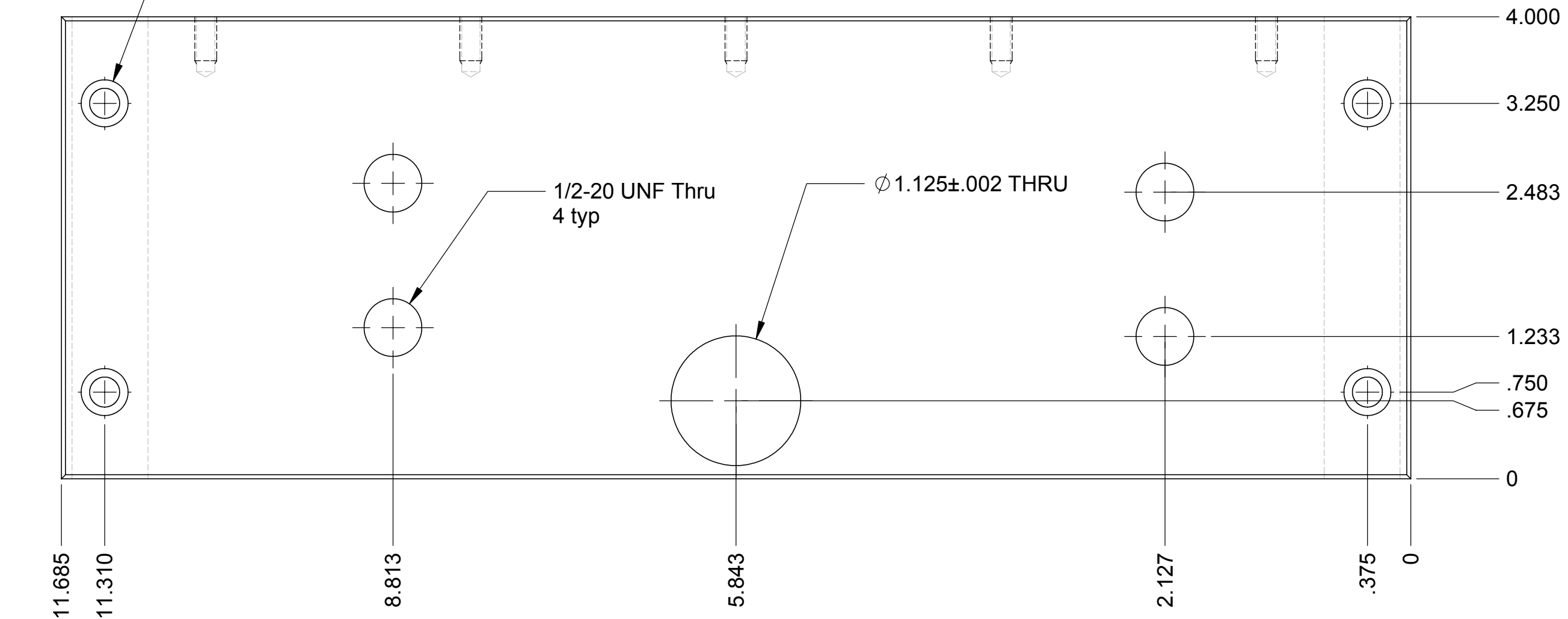
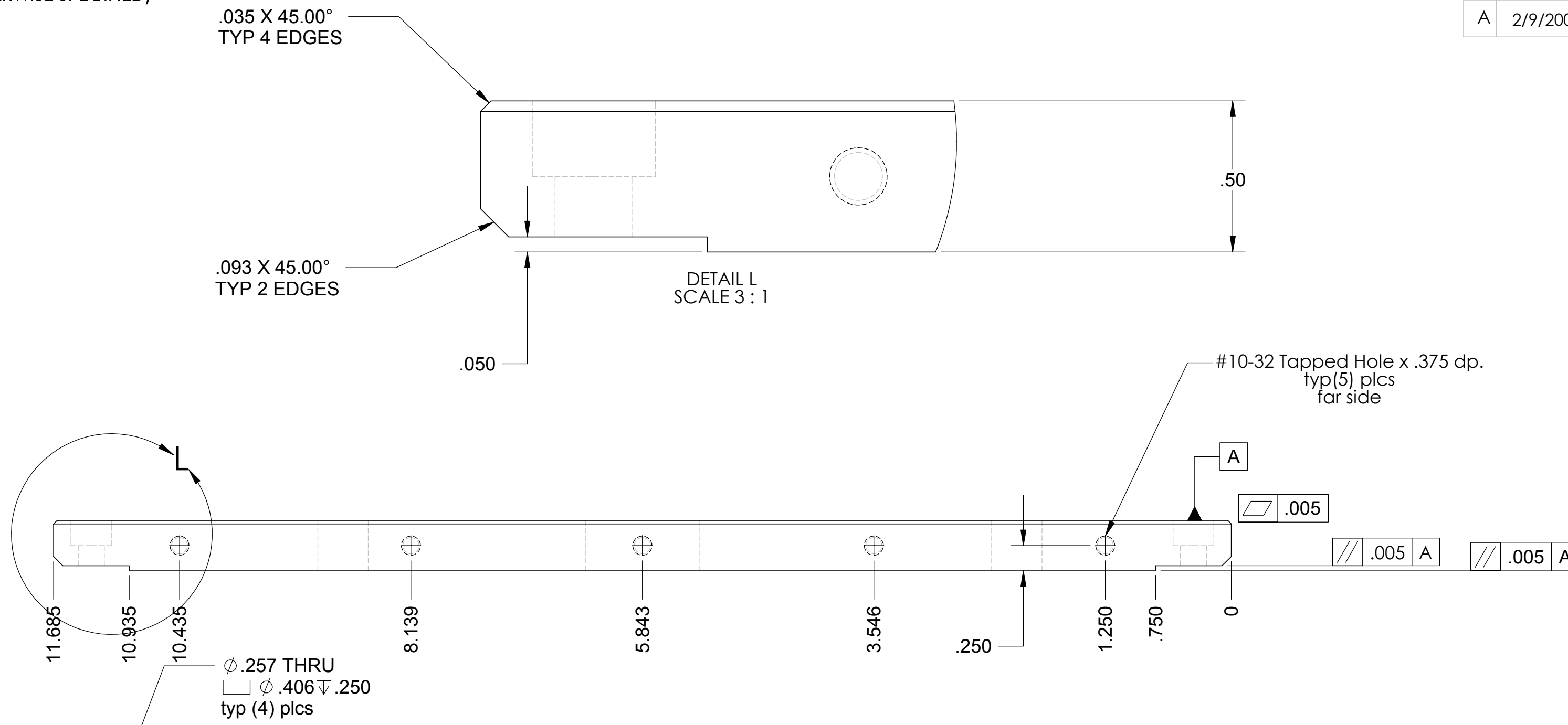

UNLESS OTHERWISE SPECIFIED:		DATE	NAME	CALIFORNIA INSTITUTE OF TECHNOLOGY MASSACHUSETTS INSTITUTE OF TECHNOLOGY		
DIMENSIONS ARE IN INCHES		DRAWN	4/02		Hardham	
TOLERANCES:		REDRAWN	Fall 02		Hammond	
.XX ± 0.02"		CHECKED	2/9/03		Kern	
.XXX ± 0.001"					SYSTEM	LASTI
ANGULAR ± 30'					SUB-SYSTEM	HEPI
MATERIAL:		COMMENTS:			NEXT ASSY	
304 L		1 Required for each actuator			PART NAME	
FINISH					Left Side Foundation Plate	
32 RMS unless noted					SIZE	DWG. NO.
					C	D020297-A-E
					SCALE:	1:1 unless noted
						REV
						A