

REV	DATE	DCN #	DRAWING TREE #

NOTES: (UNLESS OTHERWISE SPECIFIED)

- NOTES: UNLESS OTHERWISE SPECIFIED
1. REMOVE ALL BURRS AND BREAK SHARP EDGES TO A MAXIMUM OF .015
  2. PART NUMBER (DRAWING NO., DASH NO., REVISION NO., SERIAL NO.) TO BE CLEARLY MARKED ON THE PART ITSELF
  3. PAINT:  
ALL VISIBLE SURFACES  
MEDIUM BLUE SHERWIN WILLIAMS (POLANE (R) T-PLUS  
POLYURETHANE ENAMEL) #SW-F63TX-L-2822-5864  
PRIME WITH SHERWIN WILLIAMS INDUSTRIAL WASH PRIMER P60G2
  4. BOTH TAPPED AND THRU HOLES WILL BE PLUGGED DURING APPLICATION.
  5. FULL WELDED CONSTRUCTION. STRESS RELIEVE BEFORE FINISH MACHINING.

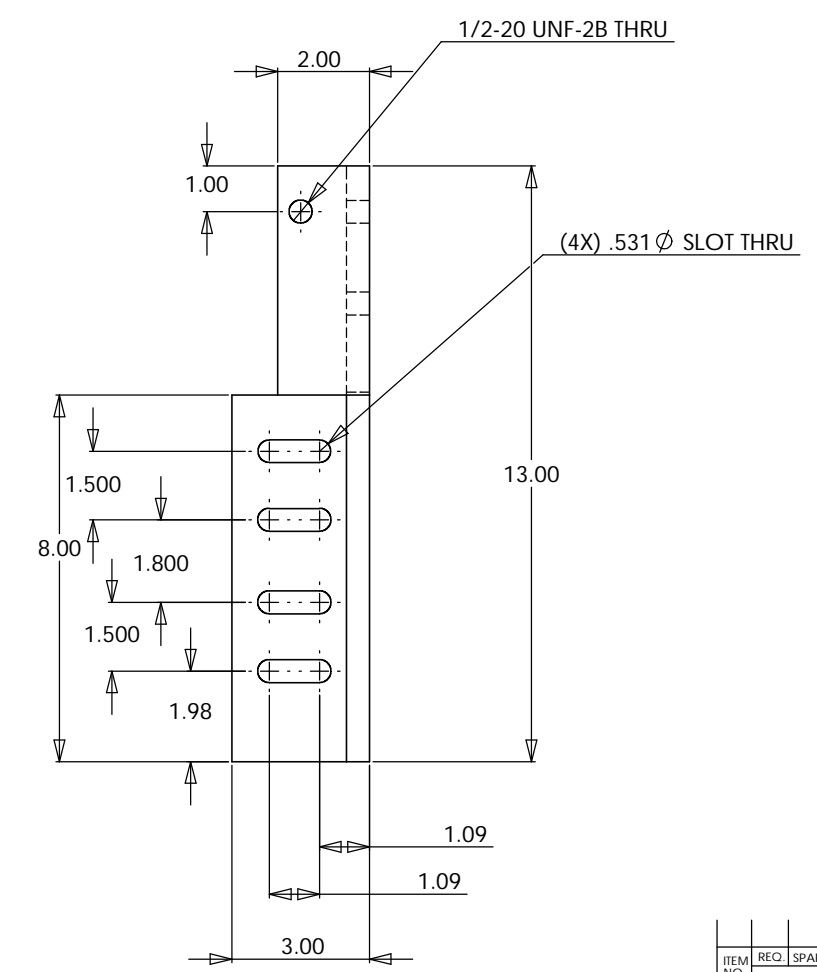
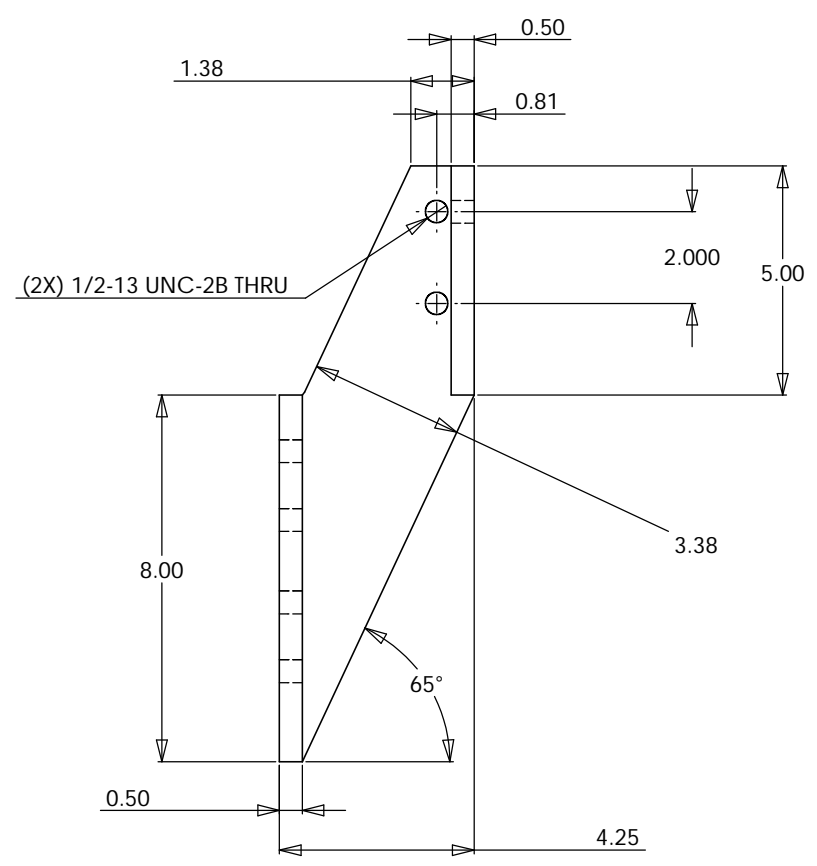
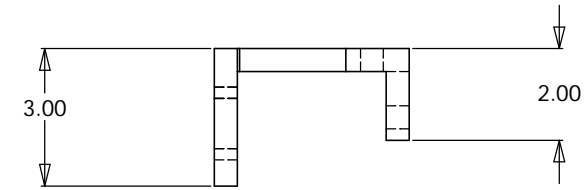
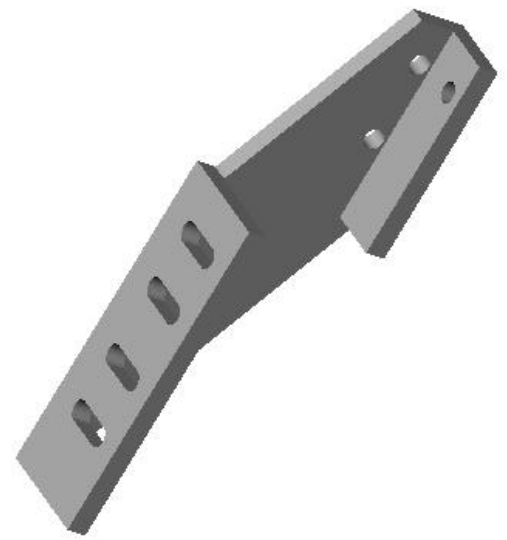

ITEM NO.	REQ. QUANTITY	SPARE	TOT.	PART NUMBER	DESCRIPTION	SUPPLIER
<b>PARTS LIST</b>						
UNLESS OTHERWISE SPECIFIED:				DATE	NAME	CALIFORNIA INSTITUTE OF TECHNOLOGY
DIMENSIONS ARE IN INCHES				5/20/02	K.MASON	MASSACHUSETTS INSTITUTE OF TECHNOLOGY
TOLERANCES:				CHECKED	SYSTEM	
XX ± .02						
XXX ± .005						
ANGULAR ± 1						
MATERIAL:				COMMENTS:	SIZE	DWG. NO.
1018 CRS					D	D020249-A
FINISH:					SCALE: 1:1	REV
SEE NOTES						A
						SHEET 1 OF 1