

Inner Loop (IL)

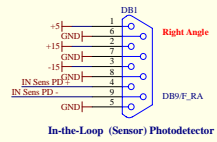

In-the-Loop (Sensor) Photodetector

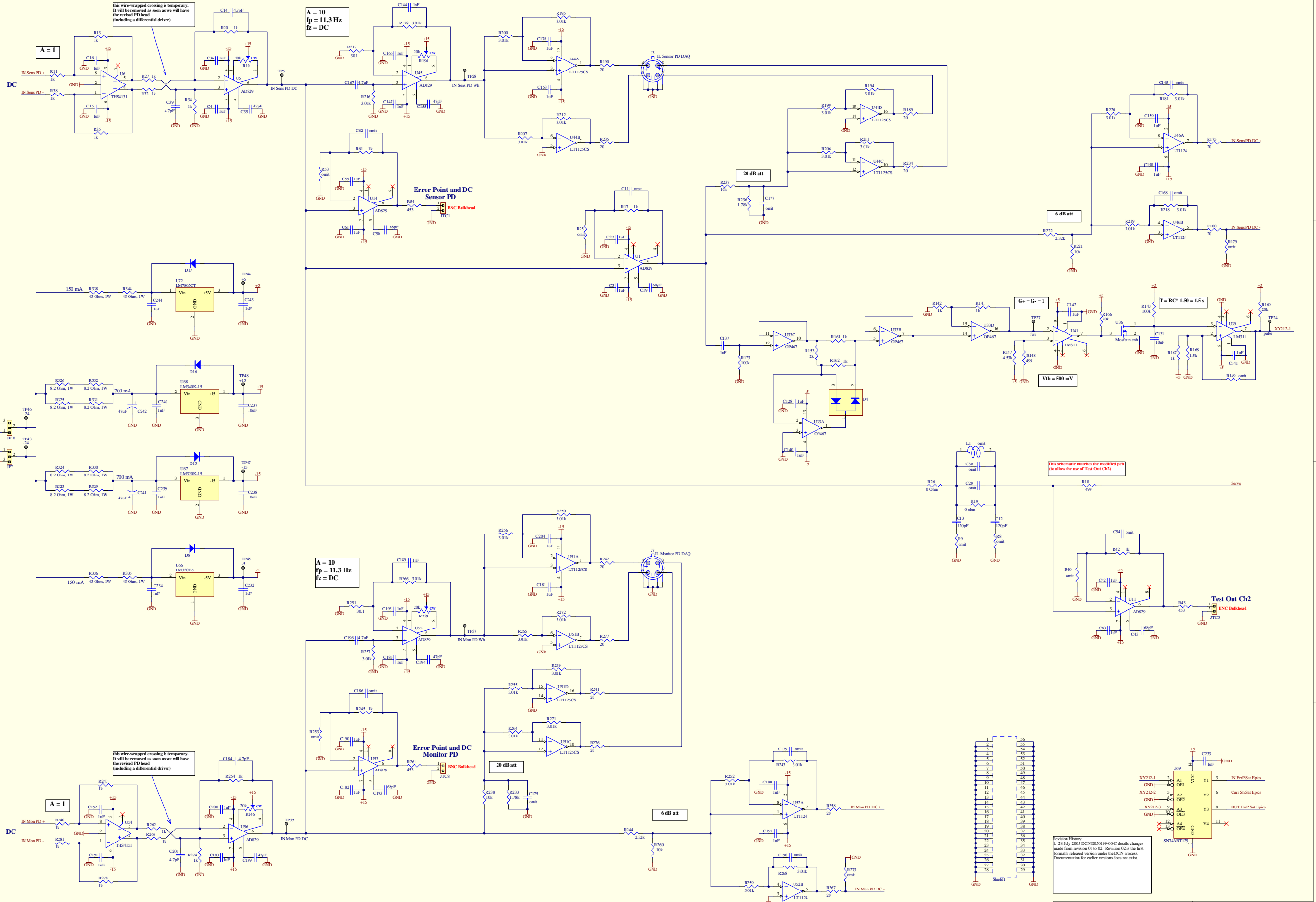
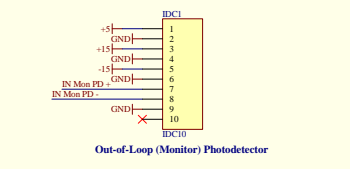
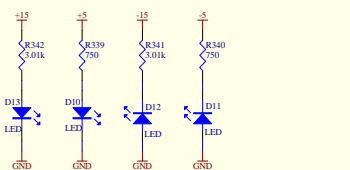
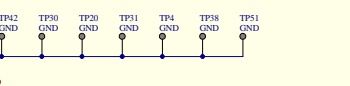
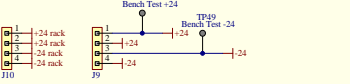
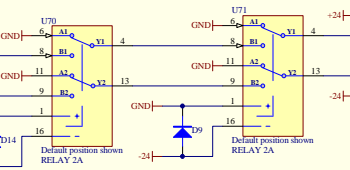
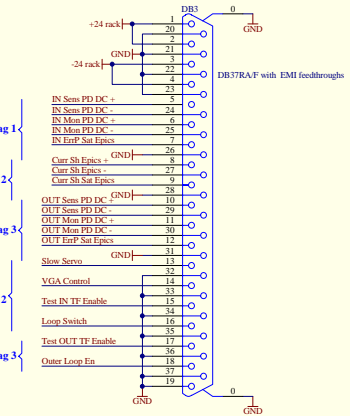

Revision History:

Rev	DCN	Number	Revision	Engineer	Date
1	28 July 2005	DCN E950199-00-C	details changes made from revision 01 to 02. Revision 02 is the first formally released version under the DCN process.	F. Nicora/R. Abbot	8:42:18 AM
2			Documentation for earlier versions does not exist.		

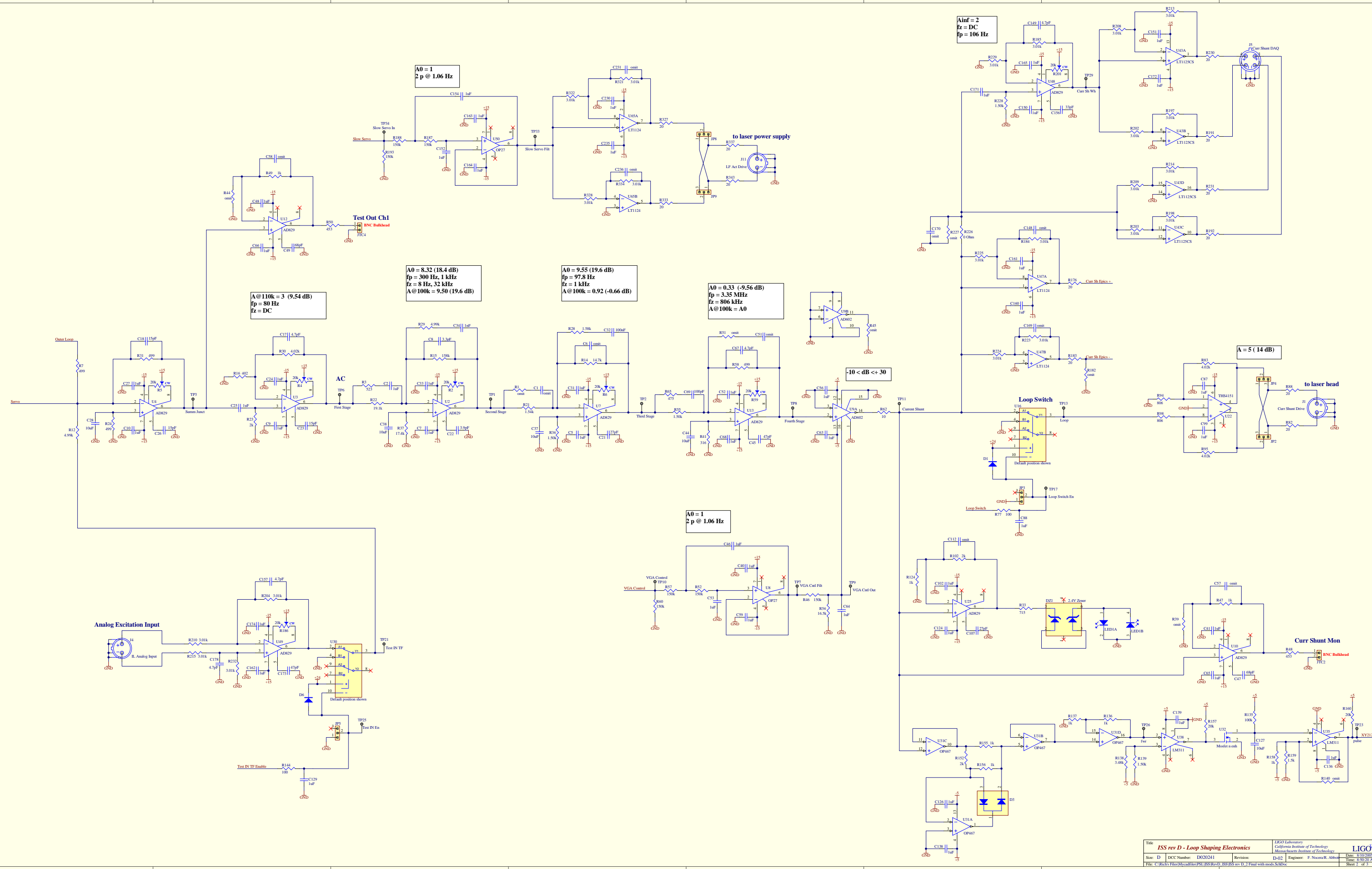

Outer Loop (OL)

