

-1 24x48 LID MAT'L: 6061-T6 ALUMINUM; 6 REQ'D.

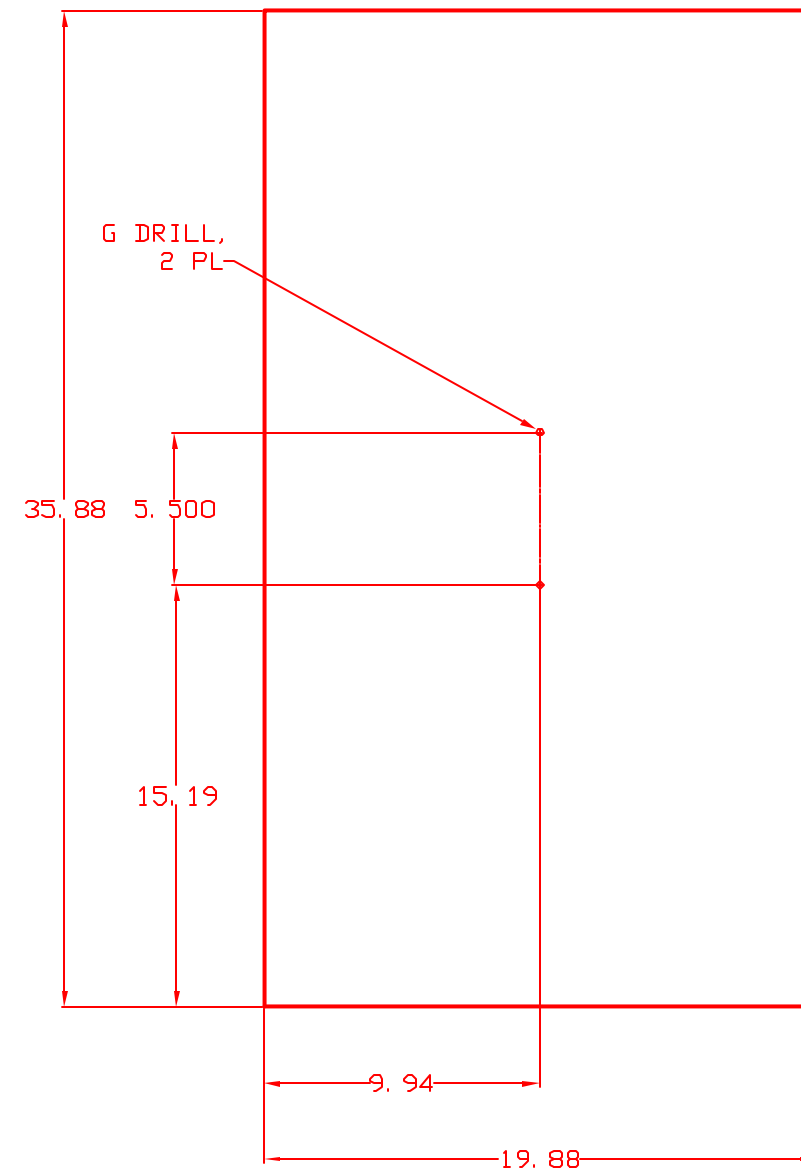

-2 20x36 LID MAT'L: 6061-T6 ALUMINUM; 3 REQ'D.

MATERIAL THICKNESS, ALL LIDS: 10 GA

NOTES:

1. REMOVE ALL SHARP EDGES.
2. ETCH FOR MATTE FINISH
3. HARD ANODIZE DYE BLACK.
4. TAKE CARE TO PRESERVE FLATNESS DURING FABRICATION AND SHIPPING.

ALL DIMENSIONS ARE IN INCHES

TOLERANCES: X, XXX: +/- 0.005"
 X, XX: +/- 0.03"
 X, X: +/- 0.1"

D020092-01-R

LIDS #1, TABLE COVER
 40M LAB LIGO PROJECT
 L JONES 6/20/02