

- NOTES: UNLESS OTHERWISE SPECIFIED
1. REMOVE ALL BURRS AND BREAK SHARP EDGES TO A MAXIMUM OF .015
 2. PART NUMBER (DRAWING NO., DASH NO., REVISION NO., SERIAL NO.) TO BE CLEARLY MARKED ON THE PART ITSELF
 3. PAINT:
ALL VISIBLE SURFACES
MEDIUM BLUE SHERWIN WILLIAMS (POLANE (R) T-PLUS POLYURETHANE ENAMEL) #SW-F63TX-L-2822-5864
PRIME WITH SHERWIN WILLIAMS INDUSTRIAL WASH PRIMER P60G2
 4. "OXI SOLV RUST INHIBITOR" TO BE APPLIED PER MFG. INSTRUCTIONS TO ALL UNPAINTED SURFACES.
BOTH TAPPED AND THRU HOLES WILL BE PLUGGED DURING APPLICATION.

REV.	DATE	DCN #	DRAWING TREE #

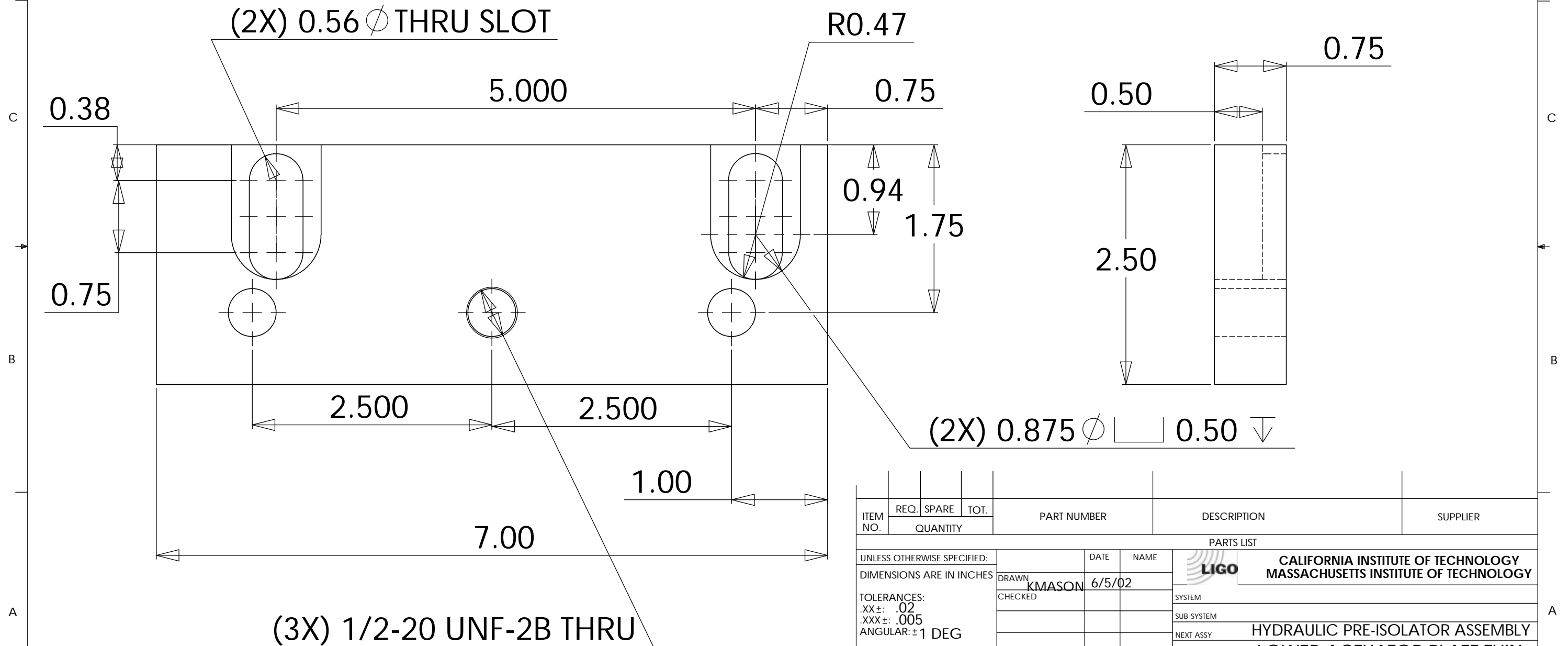

ITEM NO.	REQ. QUANTITY	SPARE	TOT.	PART NUMBER	DESCRIPTION	SUPPLIER
PARTS LIST						
UNLESS OTHERWISE SPECIFIED: DIMENSIONS ARE IN INCHES TOLERANCES: .XX ±: .02 .XXX ±: .005 ANGULAR: ±1 DEG				DRAWN KMASON	DATE 6/5/02	NAME LIGO
MATERIAL 1018 CRS				CALIFORNIA INSTITUTE OF TECHNOLOGY MASSACHUSETTS INSTITUTE OF TECHNOLOGY		
FINISH SEE NOTES				SYSTEM SUB-SYSTEM NEXT ASSY HYDRAULIC PRE-ISOLATOR ASSEMBLY		
				PART NAME LOWER ACTUATOR PLATE THIN		
				SIZE B	DWG. NO. D020010-A-D	REV A
				SCALE: 1:1	D020010-A.SLDPRT	SHEET 1 OF 1