

# LASER INTERFEROMETER GRAVITATIONAL WAVE OBSERVATORY

- LIGO -

CALIFORNIA INSTITUTE OF TECHNOLOGY  
MASSACHUSETTS INSTITUTE OF TECHNOLOGY

Document Type <b>Technical Note</b>	DCC Number <b>LIGO-D010251-00-R</b>	Date 30 <sup>th</sup> October 2001
<b>TAMA Seismic Attenuation System (SAS) tower</b>		
<b>Shipping Crate drawings</b>		
<b>Riccardo DeSalvo (LIGO)</b>		

Distribution of this draft: TBD  
This is an internal working note  
of the LIGO Project.

California Institute of Technology  
LIGO Laboratory - MS 18-34  
Pasadena CA 91125  
Phone (626) 395-212  
Fax (626) 304-9834  
E-mail: [info@ligo.caltech.edu](mailto:info@ligo.caltech.edu)

Massachusetts Institute of Technology  
LIGO Laboratory - MS 16NW-145  
Cambridge, MA 01239  
Phone (617) 253-4824  
Fax (617) 253-7014  
E-mail: [info@ligo.mit.edu](mailto:info@ligo.mit.edu)

www: <http://www.ligo.caltech.edu/>

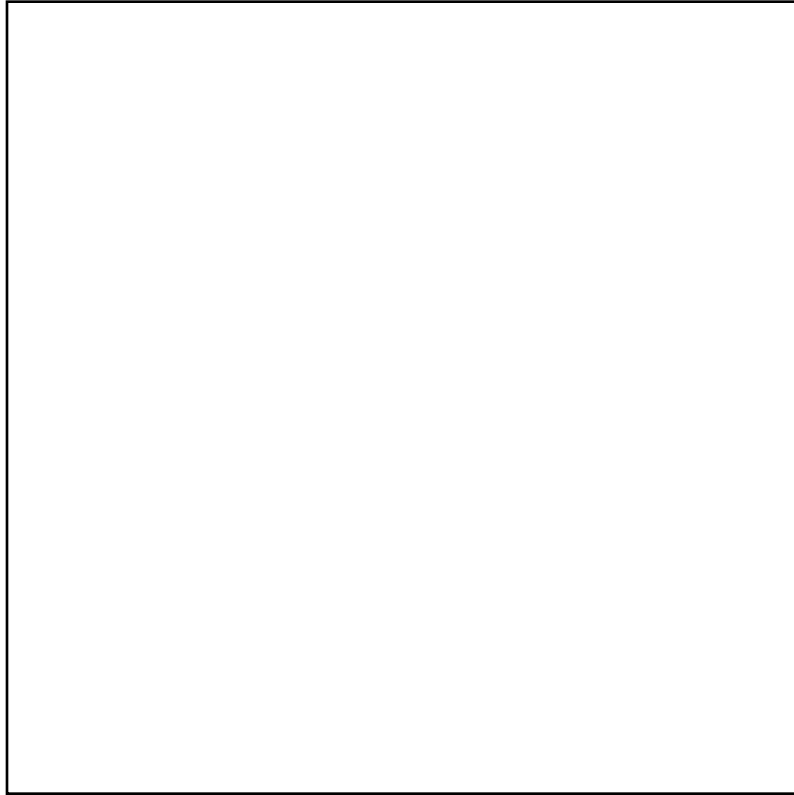

1 x 40 x 40 bottom and top plates 4 pieces

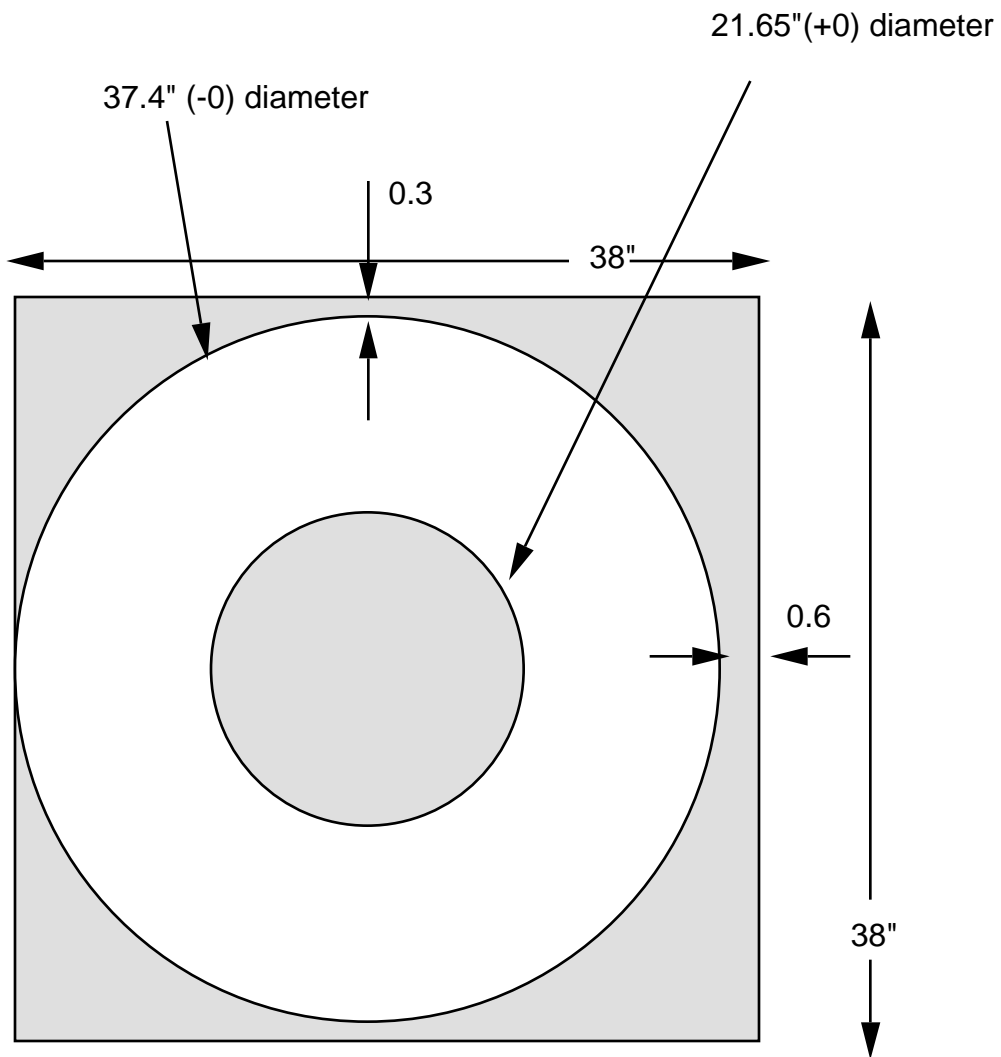

cutting plan for bottom positioning plates  
2 pieces 1 thick and 2 pieces 3/4 thick

TOP COVER RETAINER CUTTING

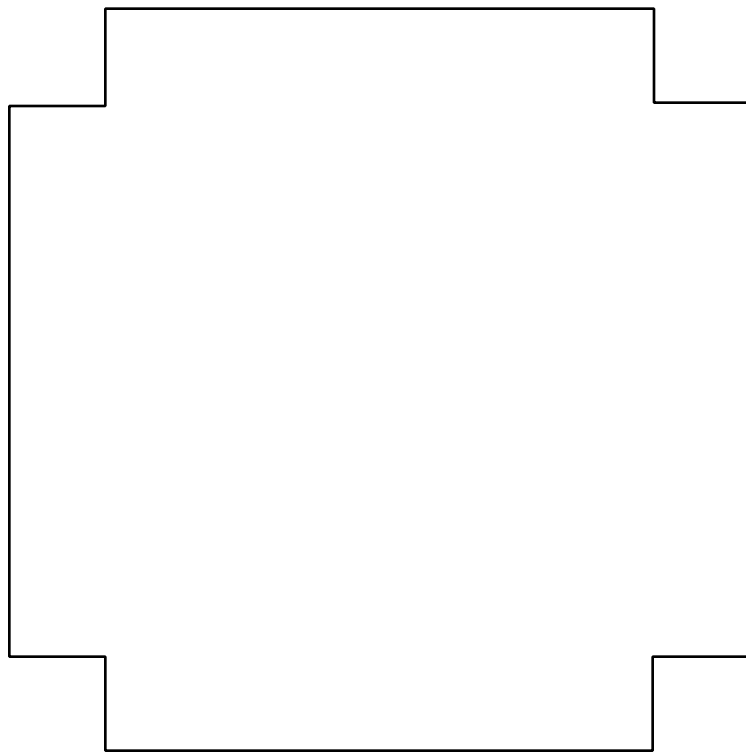

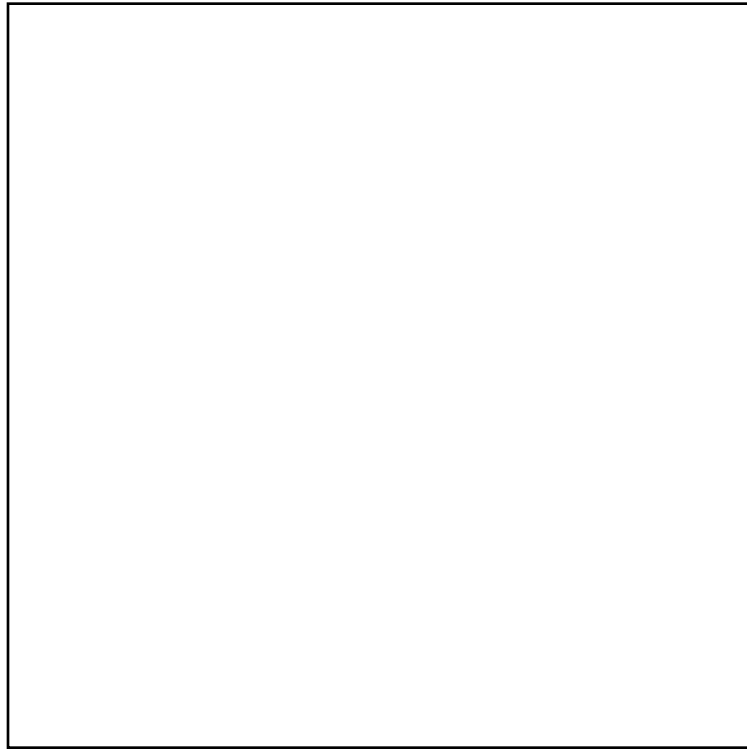

1 x 38 x 38 bottom positioning plates 2 pieces  
3/4 x 38 x 38 bottom positioning plates 2 pieces  
3/4 x 38 x 38 top retainer plates 2 pieces

BOTTOM ASSEMBLY

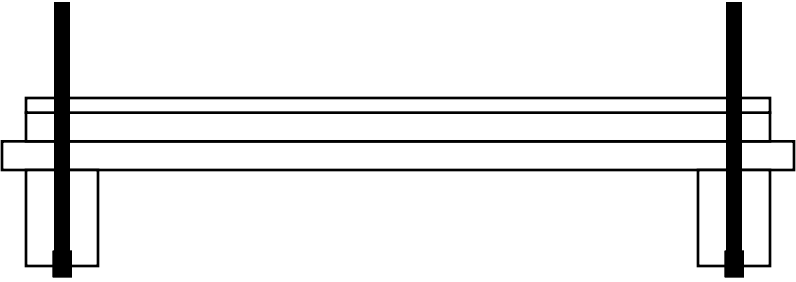
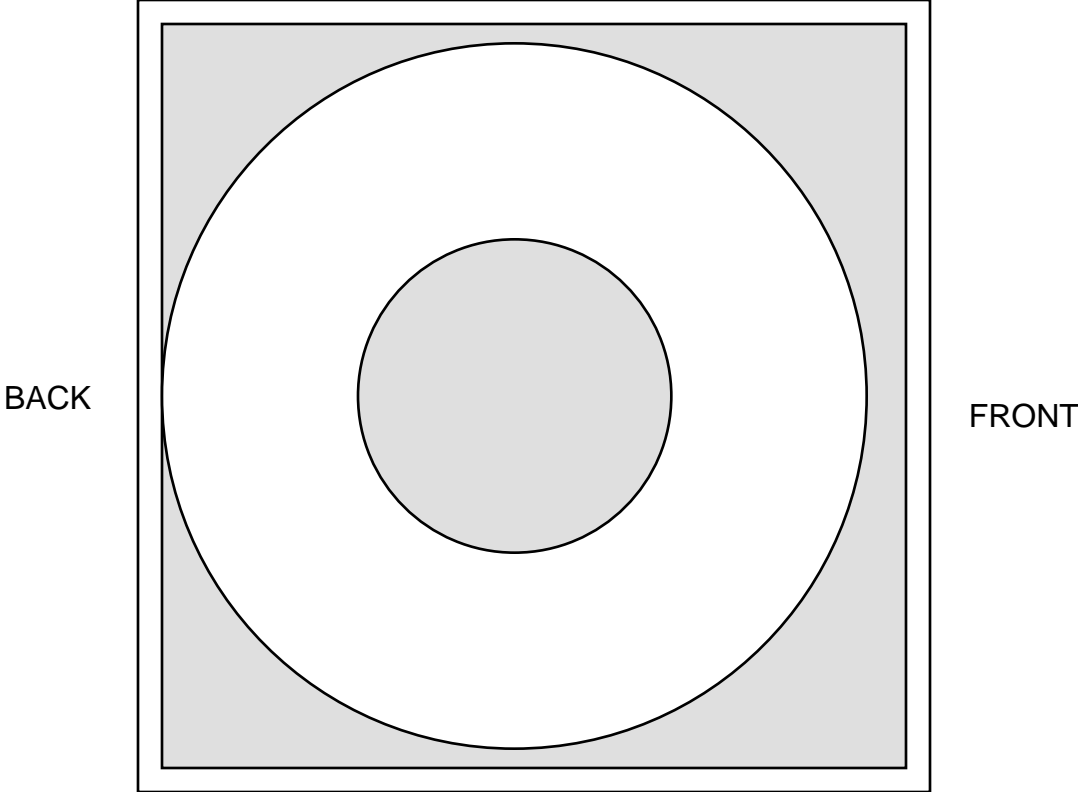

1/2-13 CARRIAGE BOLT  
SCREWED AND GLUED TOGETHER

TOP ASSEMBLY

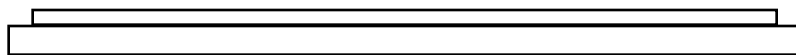
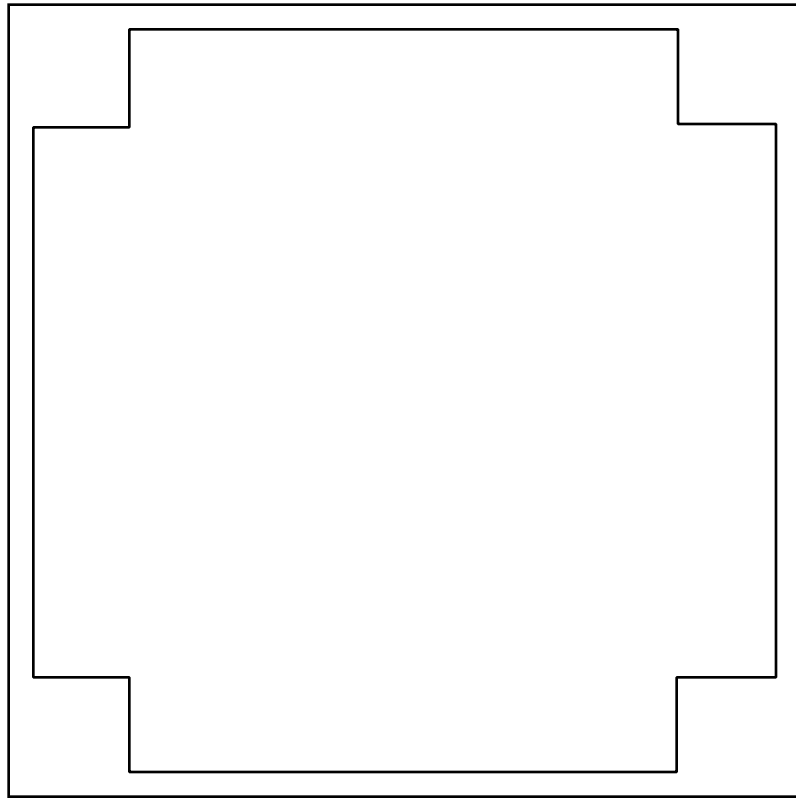

SCREWED AND GLUED TOGETHER

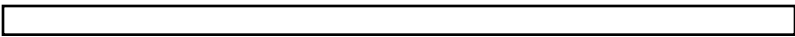
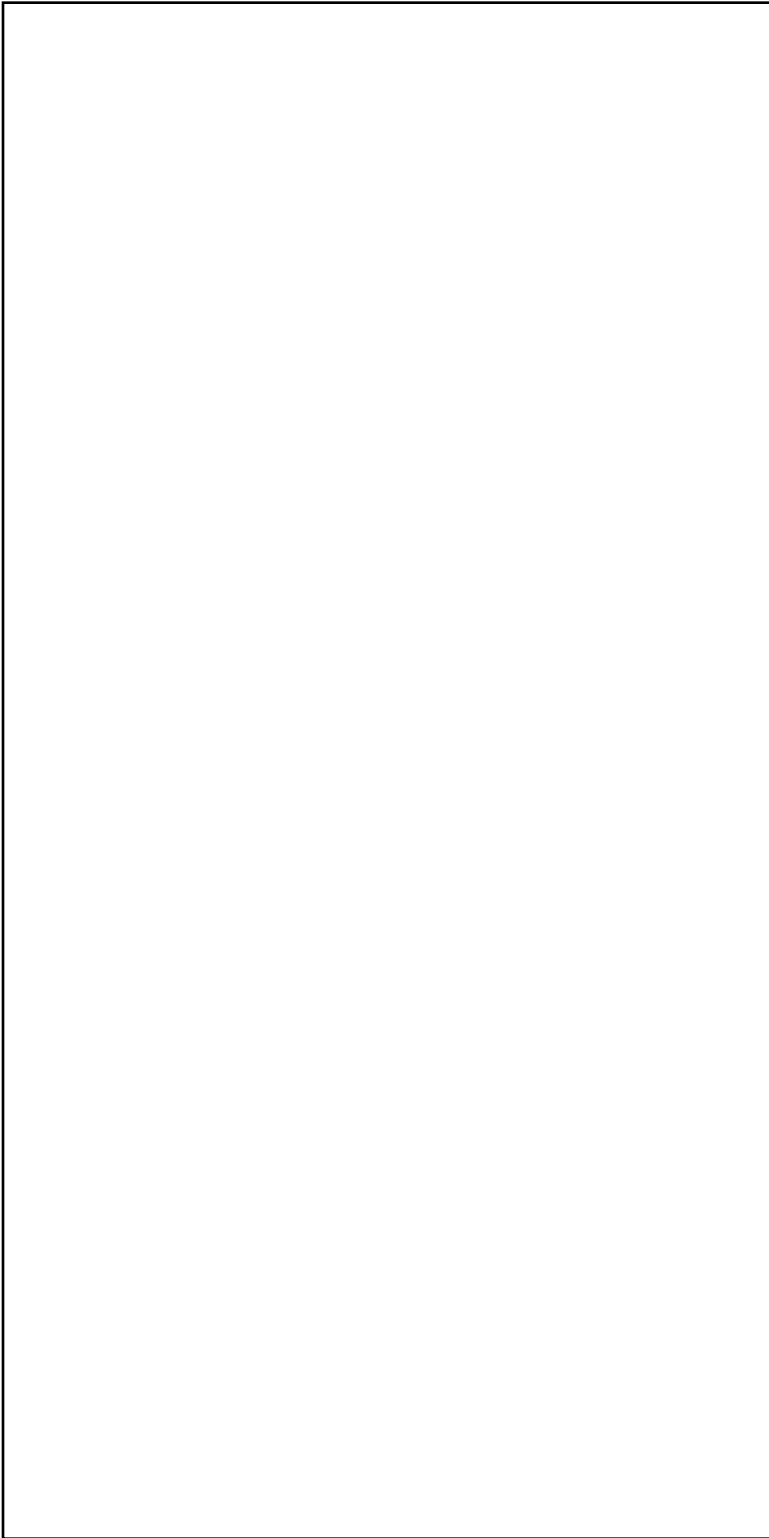

1 X 40 X 80  
FRONT AND BACK PLATES  
4 PIECES



BACK PANEL ASSEMBLY

SCREWED AND GLUED TOGETHER



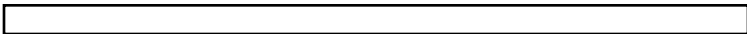
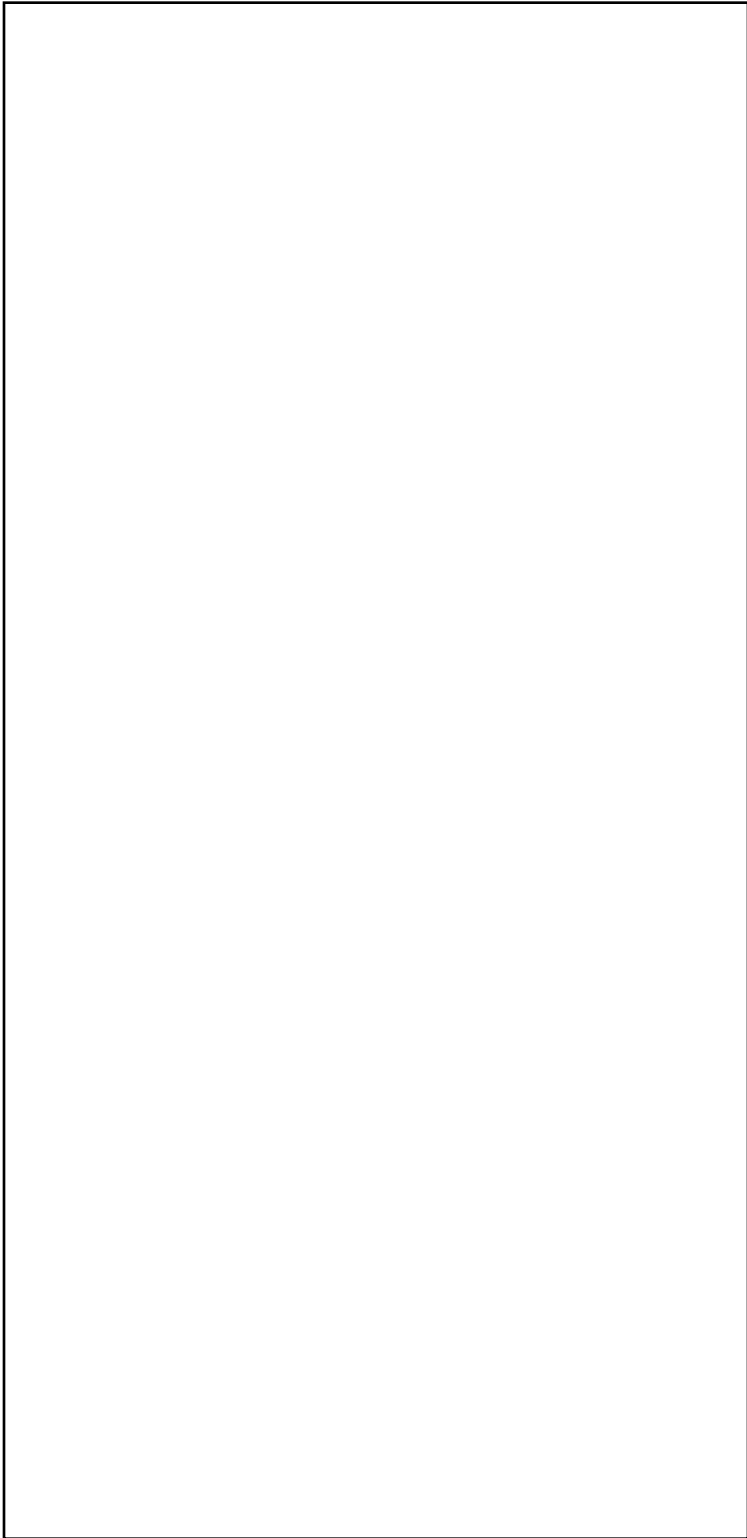

1 X 38 X 80  
SIDE PLATES  
4 PIECES

FRONT PANEL ASSEMBLY

SCREWED AND GLUED TOGETHER

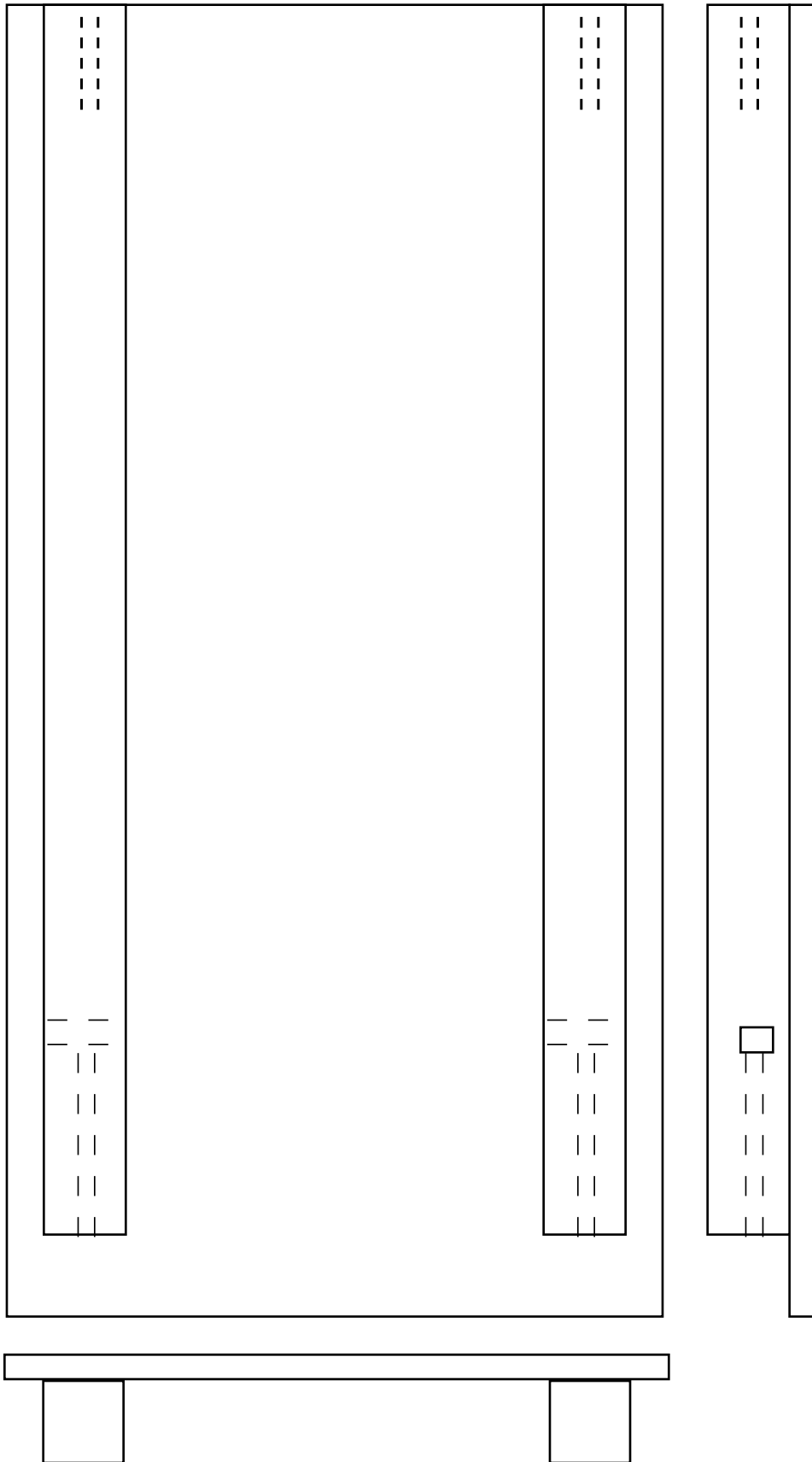

1/2-13  
THREADED  
INSERTS

NUT LOCKING  
ACCESS  
ON THE SIDES



4 x 6 x 20  
pallet feet  
10 pieces

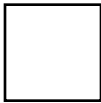

3-1/2 X 3-1/2 X 78-1/2  
PLANED  
8 PIECES

TOP VIEW OPEN CRATE

FRONT PANEL

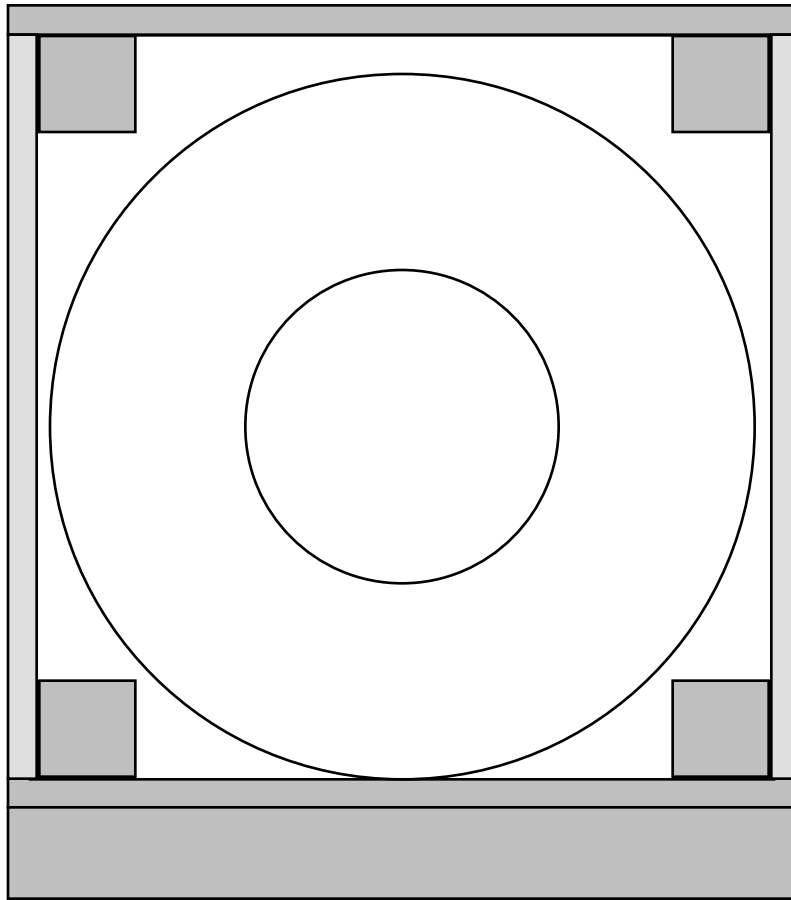

BACK PANEL