

1

2

3

4

| REV | DATE   | DRAWN BY | CHECKED | DCC | DCN/DESCRIPTION         |
|-----|--------|----------|---------|-----|-------------------------|
| A   | 9/5/01 | J. Romie |         |     | E010162/INITIAL RELEASE |

NOTES: (UNLESS OTHERWISE SPECIFIED)  
 1. DIMENSIONS IN INCHES.  
 2. BREAK ALL SHARP EDGES.  
 3. ALL MACHINING FLUIDS SHALL BE WATER SOLUABLE AND FREE OF SULFUR, CHLORINE AND SILICONE, SUCH AS CINCINNATI MILACRON'S CIMTECH 410 (STAINLESS STEEL.)  
 ④ ETCH OR STAMP THE DRAWING PART NUMBER ON NOTED SURFACE OF PART AND THEN A THREE DIGIT SERIAL NUMBER. SERIAL NUMBERS START AT 001 FOR THE FIRST PART AND PROCEED CONSEQUETIVELY. USE .07" HIGH CHARACTERS. EXAMPLE: D010175-A 001

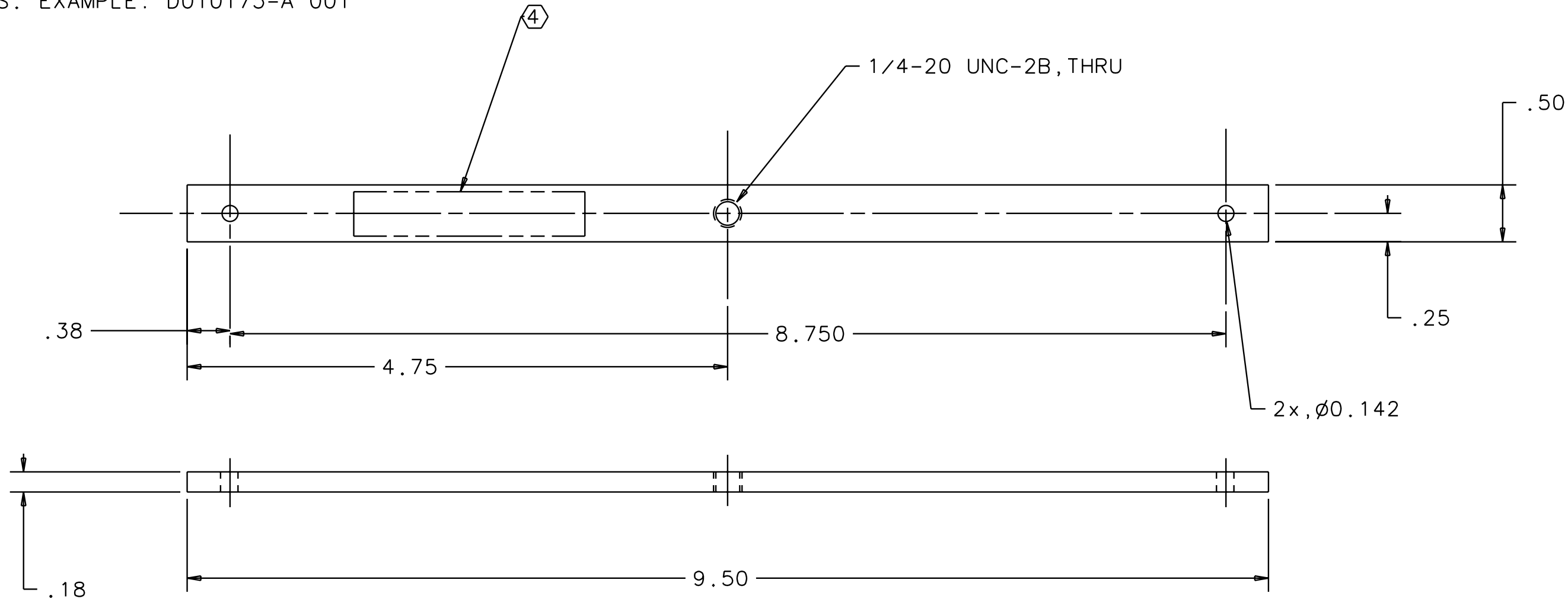

| QTY REQD   | FSCM NO | PART OR IDENTIFYING NO     | NOMENCLATURE OR DESCRIPTION           | MATERIAL SPECIFICATION | ITEM NO  |
|--|---------|----------------------------|---------------------------------------|------------------------|--|
| PARTS LIST   |         |                            |                                       |                        |  |
| UNLESS OTHERWISE SPECIFIED DIMENSIONS ARE IN INCHES TOLERANCES ARE:<br>FRACTIONS DECIMALS<br>0.XX±0.01<br>0.XXX±0.005<br>ANGLES±0.5°<br>DO NOT SCALE DRAWING |         |                            | APPROVALS<br>DRAWN J.ROMIE<br>CHECKED | DATE<br>9/01           | TITLE<br>LIGO CALIFORNIA INSTITUTE OF TECHNOLOGY<br>MASSACHUSETTS INSTITUTE OF TECHNOLOGY<br>40m TM SAFETY BAR |
| NEXT ASSEMBLY<br>D010163   |         | MATERIAL<br>300 SERIES SST | DWC NO.<br>D010175                    |                        | REV<br>A   |
| FILE LOCATION<br>/home/dcc/docs/D010175.pdf  |         | SCALE 1/1                  |                                       | SHEET 1 OF 1           |  |

1

2

3

4