

NOTES: (UNLESS OTHERWISE SPECIFIED)

Liquid contaminants/Machining Lubricants
Liquids containing hydrocarbons or other contaminants, other than the machining fluids specified herein, shall not be allowed to come into contact with suspension material at any time. All machining fluids shall be water soluble and free of sulfur, chlorine and silicone; such as Cincinnati Milacron's Cimtech 410 (stainless steel).

Identification Serial Number

A serial number shall be etched, or scribed on the part see note drawing note.

Serial Number Format

The Serial number shall be of the format: D99xxxx-x-001

Example: D990021-A-001

The drawing number, The revision number, The sequential part number

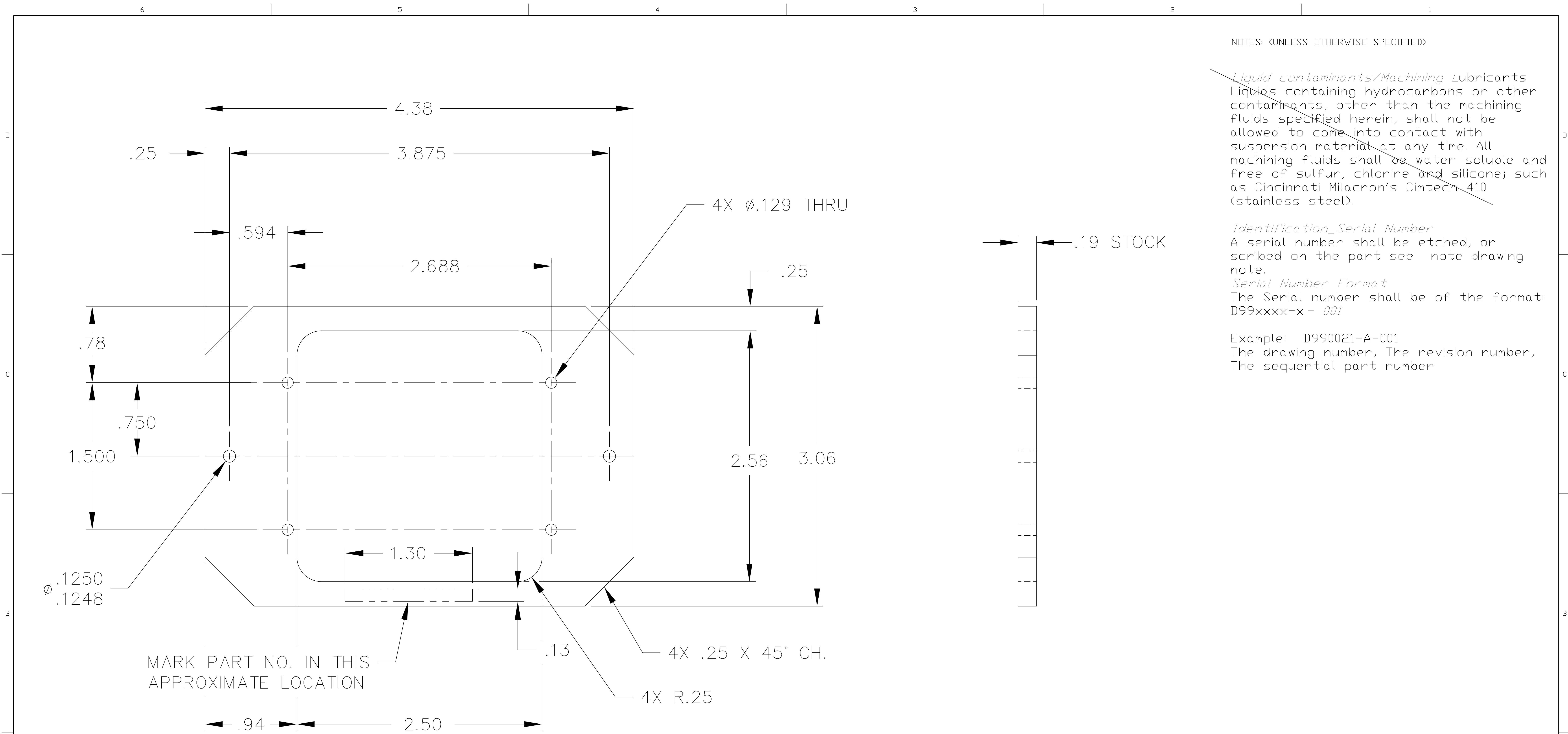
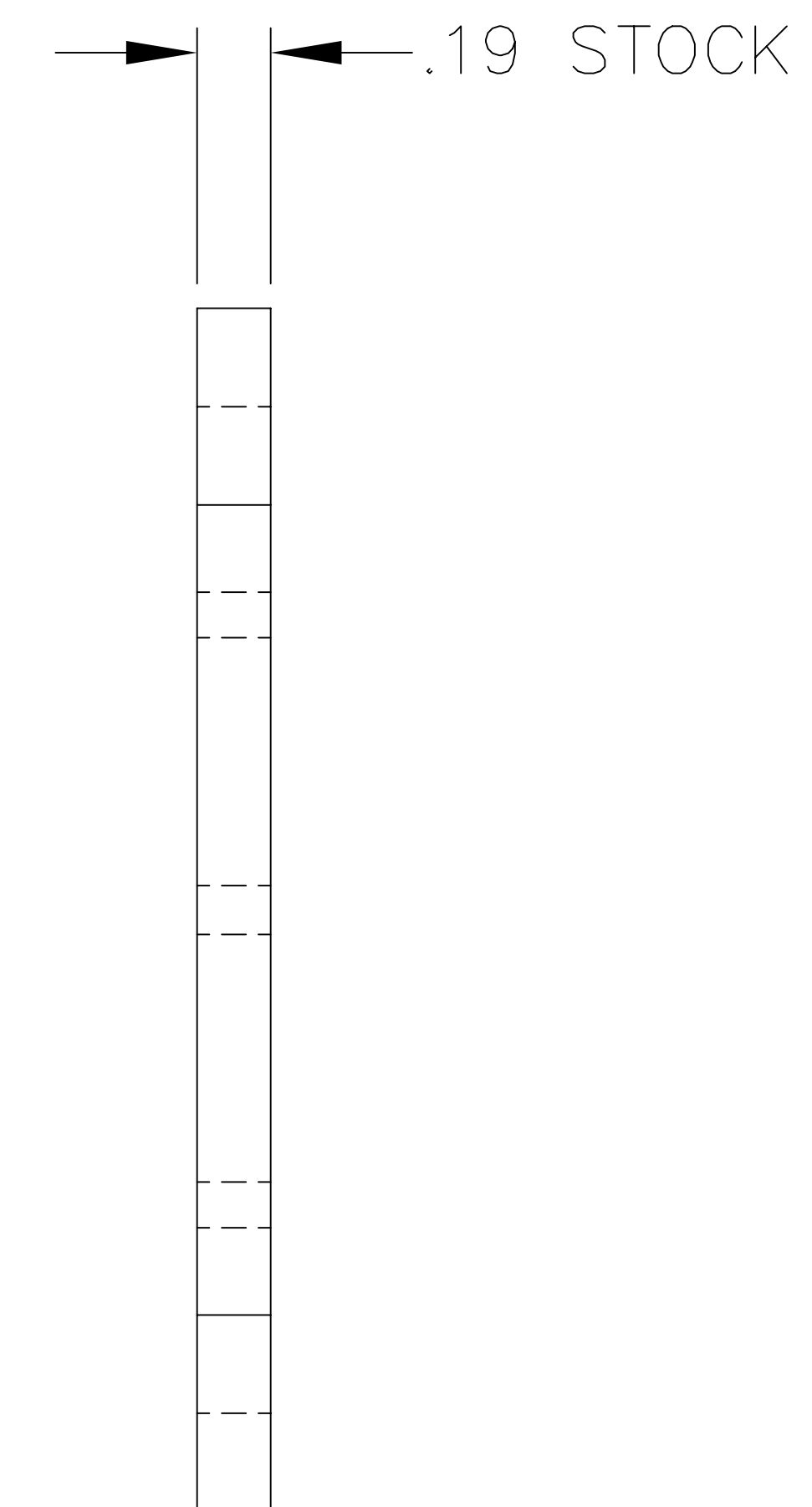

REF. MAKE 2 TOTAL

DOES NOT REMAIN IN VACUUM

REF.	QTY.	PART or DRWG No.	NOMENCLATURE or DESCRIPTION	MATERIAL
PARTS and MATERIAL LIST				

		UNLESS OTHERWISE SPECIFIED DIMENSIONS ARE IN INCHES					LIGO CALIFORNIA INSTITUTE OF TECHNOLOGY MASSACHUSETTS INSTITUTE OF TECHNOLOGY		
		TOLERANCES: FRACTIONAL ±1/16 ANGULAR ±.25° ANGULAR MACH ± BEND ± TWO PLACE DECIMAL ± .01		THREE PLACE DECIMAL ± .005 FINISHED SURFACE RMS 6.3 BREAK CORNERS IN: .015 OUT: .015 REMOVE ALL BURRS				FRAME, TARGET, PD TELESCOPE	
DWG. NO.	DESCRIPTION	MATERIAL: 6061 T-6 ALUM.	HEAT TREAT: /	FINISH: /	00	FOR FABRICATION	LIGO-E000523-00-D	kenm	6-8-99
	REFERENCE DRAWINGS	USED ON: XXX	NEXT ASS'Y: XXX		REV	PRE-RELEASE	-	CHAPUT	11-3-98
						DESCRIPTION	DCN NUMBER	-	APPR'D CHECK DRWN DATE
					ISSUE DESCRIPTION				
								CAD FILE	D000389-A
								SIZE/DWG. NO.	B D000389-A
								SCALE	1 : 1
								SHEET	1 OF 1