

DB15 CONNECTOR MOUNTED ON FP OF MODULE. CONNECTED TO IDC 16 CONNECTOR MOUNTED ON BOARD VIA MASS TERMINATION CABLE.

Pin designations as follows:

Name	IDC Pin #	15 D pin #
UL Out	1	1
LL Out	2	9
UR Out	3	2
LR Out	4	10
UR Rim	5	3
UR Rim	6	11
LR Rim	7	4
LR Rim	8	12
S Out	9	5
S Rim	10	13
N/C	11	6
N/C	12	14

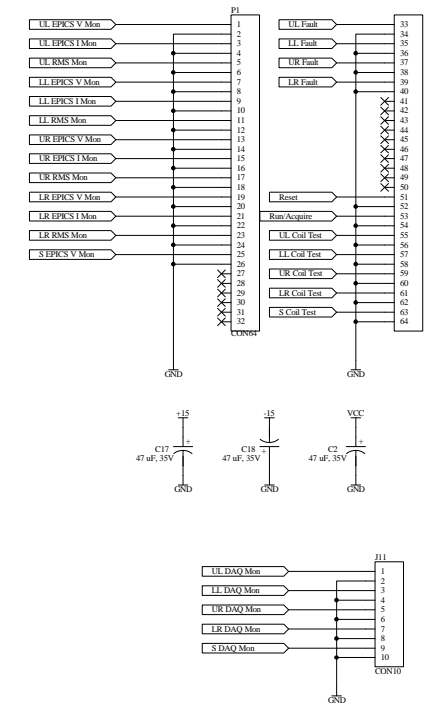

Rev	Description	Date
A	Initial Release	10/00
B	1. Changed connection of K5 to correct polarity for coil (Pins 1&6 reversed) 2. PCB traces rerouted for K5 and C64. 3. Hole sizes for PAR8s increased to allow sockets. 4. J12 rotated on PCB.	6/01
B1	Swapped pins 10 and 12 on relays K1, K2, K3, K4 and K5 to invert enable signal. Change was done by removing relays from board and adding an interface socket to make the switch.	10/01
B2	1. Changed C47, C45, C74, C72 to 47pF. 2. Changed R88, R83, R137, R129 to 110 ohms. (Better compensation of PAR8s)	1/02
B3	Rev B3 revision notes: Rev B3 typically applies to BS, RM, ITMs and ETMs 1. 7.2K feedback resistor is changed to 21.6K ohms (3 ea. 7.2K in series) 2. 1Kohm in series with SuF is changed to 100K in series with 5uF for BS, RM and ETMs. Remains at 1K for ITMs. 3. 7.2K in series with coil output is changed to 3 ea. 1K in series. 4. 10 ohm current limit resistors on PAR8s changed to make a 1.4ohm current limit resistor. 5. DAQ coil output Monitors changed to have 0.05uF capacitor and 10K resistor, making a 300Hz HPF.	9/02
C	Board release incorporating all Rev B changes	1/03

Title: **LOS Coil Driver**  
 LIGO Laboratory  
 California Institute of Technology  
 Massachusetts Institute of Technology  
 LIGO

Size: D DCC Number: D000325 SCH / PCB Revision: C Engineer: J. Heffner Date: 11-Jan-2003  
 File: E:\lsc\lscuser\jheffner\LOS\Driver\RevC\LOSDriverRevC.Sch Time: 12:51:09 Sheet 3 of 3