

NOTES: (UNLESS OTHERWISE SPECIFIED)

① .01 WIDE X .01 DEEP CROSS HAIRS.

Liquid contaminants/Machining lubricants
Liquids containing hydrocarbons or other contaminants, other than the machining fluids specified herein, shall not be allowed to come into contact with suspension material at any time. All machining fluids shall be water soluble and free of sulfur, chlorine and silicone; such as Cincinnati Milacron's Cimtech 410 (stainless steel).

Identification, Serial Number
A serial number shall be etched, or scribbled on the part see note drawing note.

Serial Number Format
The Serial number shall be of the format: D99xxxx-x-001

Example: D990021-A-001
The drawing number, The revision number, The sequential part number

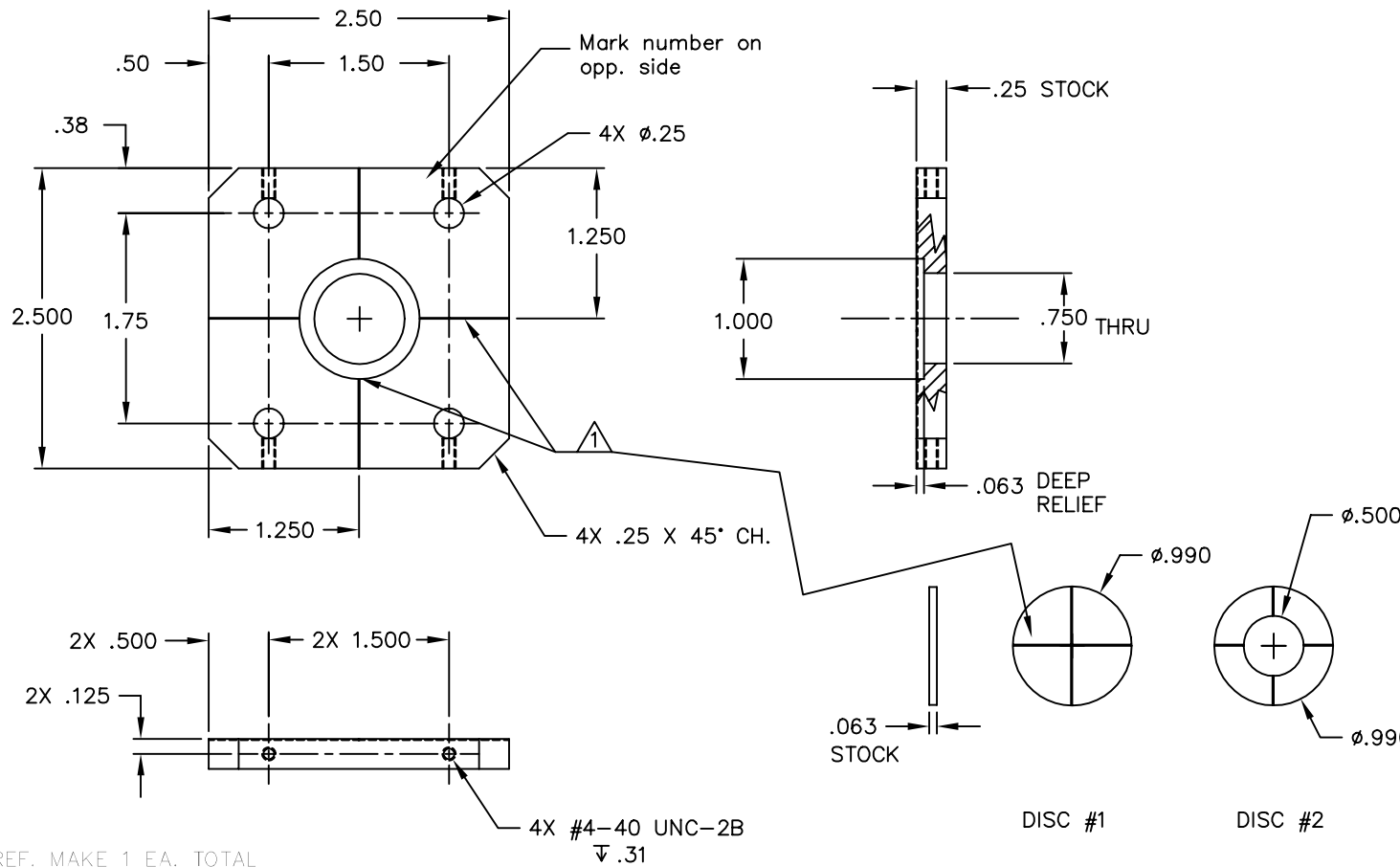

see D980575

REF. MAKE 1 EA. TOTAL

DOES NOT REMAIN IN VACUUM

REF. QTY.	PART or DRWG No.	NOMENCLATURE or DESCRIPTION	MATERIAL
PARTS and MATERIAL LIST			
			LIGO CALIFORNIA INSTITUTE OF TECHNOLOGY MASSACHUSETTS INSTITUTE OF TECHNOLOGY
			TARGET, PO Telescope Alignment
A	New Release	LIGO-E00059-00-B	Issued 3-22-00
00	PRE-RELEASE	-	CHAPUT 11-3-98
REV	DESCRIPTION	DCN NUMBER	DATE
			SCALE 1:1 SHEET 1 OF 1

UNLESS OTHERWISE SPECIFIED DIMENSIONS ARE IN INCHES			
TOLERANCES: FRACTIONAL ±1/16 ANGULAR ±.25° HOLE POSITION ±.005 TWO PLACE DECIMAL ±.01	THREE PLACE DECIMAL ±.005 FINISHED SURFACE RMS 63 BREAK CORNERS IN .015 OUT .015 REMOVE ALL BURRS	MATERIAL: 6061 T-6 ALUM.	HEAT TREAT: / FINISH: /
USED ON: XXX	NEXT ASSY: XXX		