

NOTES: (UNLESS OTHERWISE SPECIFIED)

1. FILLETS: R .015 MAX
2. BREAK ALL SHARP EDGES
.02/.01 X 45°
3. MATERIAL: ALUMINA
4. 1°±1° DRAFT ACCEPTABLE FOR CENTRAL OPENING. OPENING DIMENSIONS VALID AT DATUM -A-
5. MASK THE #4-40 THREADED HOLES AND ID. MASK SURFACE DEFINED BY DATUM -B- BEFORE COATING.
6. COAT ENTIRE HEAD WITH A THIN LAYER OF CONDUCTIVE MATERIAL TO PROVIDE UNIFORM RESISTIVITY OF .25 TO 25 OHMS/SQUARE. LASER MARK THE DRAWING PART NUMBER ON NOTED SURFACE OF PART FOLLOWED BY "S/N" THEN A THREE DIGIT SERIAL NUMBER. SERIAL NUMBERS TO START AT 001 FOR FIRST PART AND PROCEED IN A CONSECUTIVE MANNER TO A MAXIMUM OF 999, FOR EACH SUCCEEDING PART PRODUCED. USE 0.13 HIGH CHARACTERS. EXAMPLE: D000065-A S/N001

REV	DATE	DRAWN BY	CHECKED	DCC	DCN/DESCRIPTION
A	5/9/00	J. Romie			E000240/INITIAL RELEASE

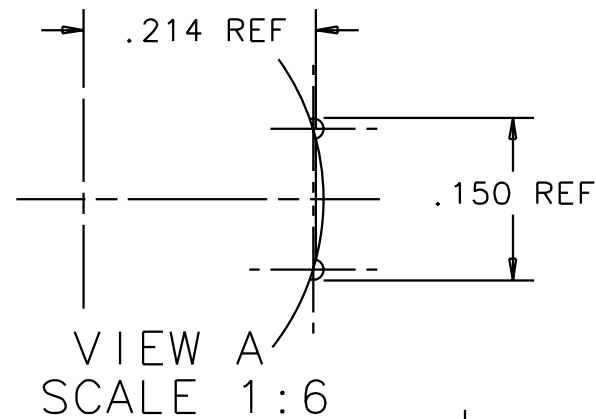
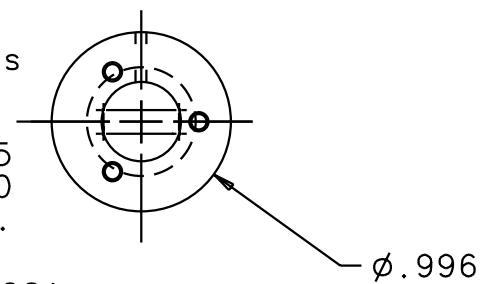
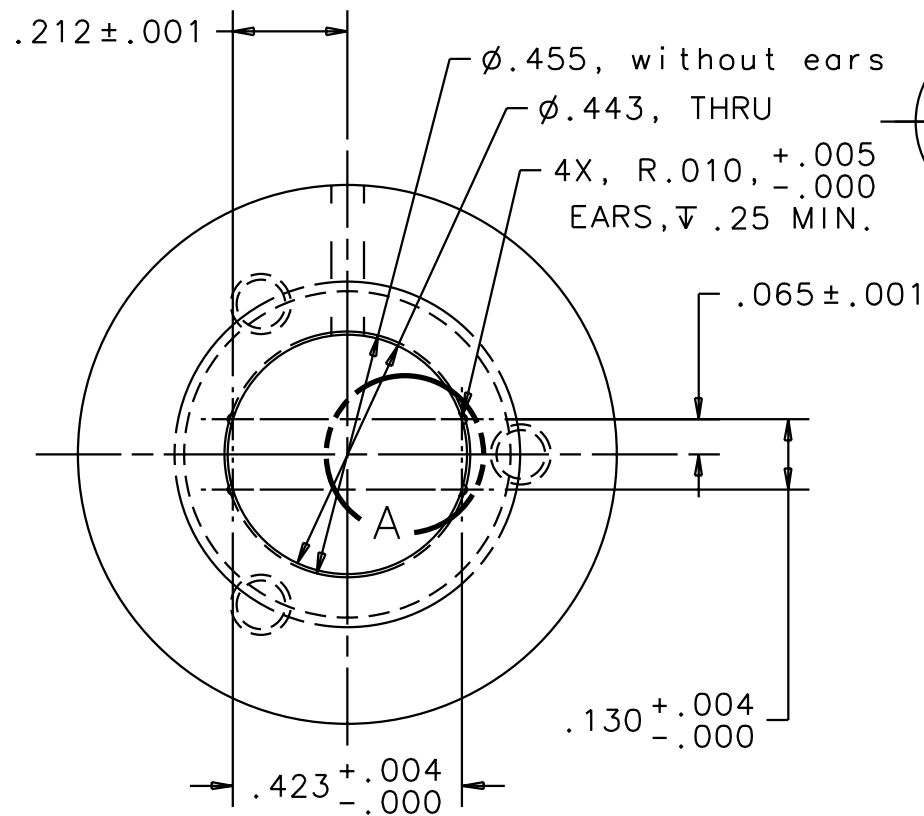
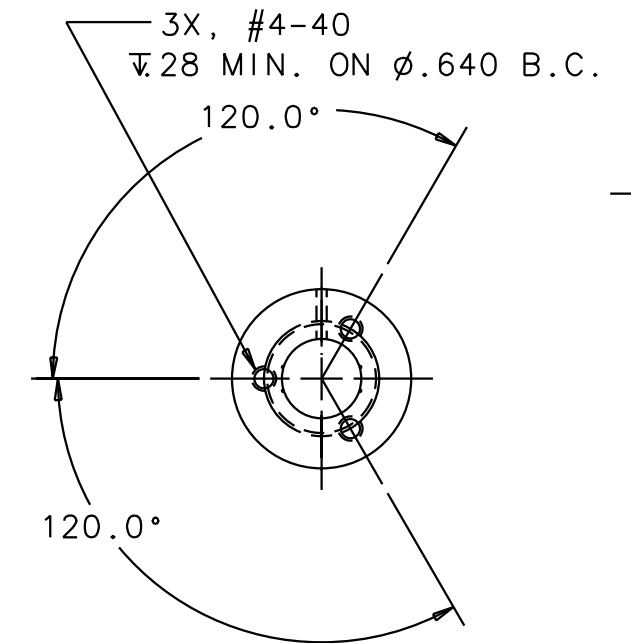
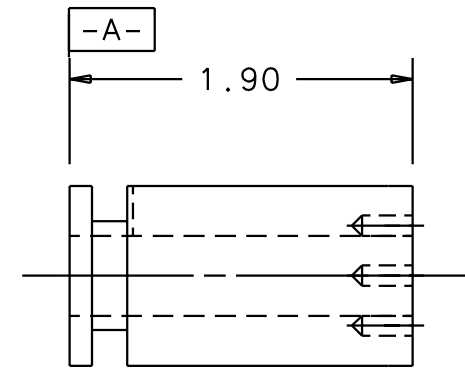
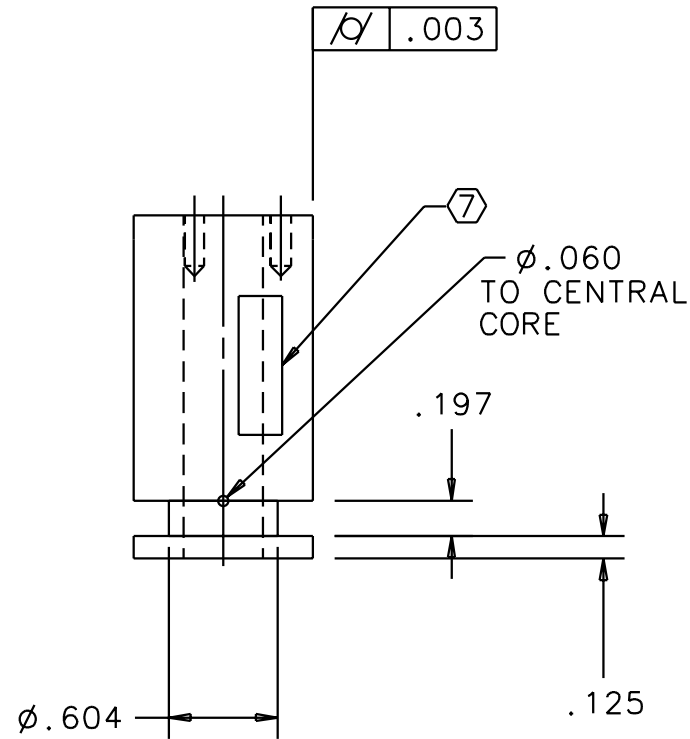

QTY REQD	PART OR IDENTIFYING NO	NOMENCLATURE OR DESCRIPTION	MATERIAL SPECIFICATION	ITEM NO
PARTS LIST				
UNLESS OTHERWISE SPECIFIED DIMENSIONS ARE IN INCHES TOLERANCES ARE: DECIMALS ANGLES		APPROVALS	DATE	CALIFORNIA INSTITUTE OF TECHNOLOGY MASSACHUSETTS INSTITUTE OF TECHNOLOGY
0.XX±0.01 0.XXX±0.005 ANGLES±0.5°		DRAWN J. ROMIE	2/00	TITLE SENSOR/ACTUATOR HEAD, LONG, SMD, ALUMINA
MATERIAL ALUMINA		CHECKED		SIZE B
FINISH 16				DWG NO. D000065
SCALE		FILENAME /home/dcc/docs/D000065.pdf		REV A
				SHEET 1 OF 1