

LASER INTERFEROMETER GRAVITATIONAL WAVE OBSERVATORY

CALIFORNIA INSTITUTE OF TECHNOLOGY
MASSACHUSETTS INSTITUTE OF TECHNOLOGY

Laser SOP	LIGO-M1000229-V1	14 October 2010
LLO 35 W PSL SOP		
Submitted By: R.S. Amin and D. Kinzel		

LIGO Hanford Observatory
P.O. Box 159
Richland, WA 99352
Phone (509) 372-8106
Fax (509) 372-8137
E-mail: info@ligo.caltech.edu

LIGO Livingston Observatory
19100 LIGO Lane
Livingston, LA 70754
Phone (225) 686-3100
Fax (225) 686-7189
E-mail: info@ligo.caltech.edu

California Institute of Technology
LIGO Project – MS 18-34
Pasadena, CA 91125
Phone (626) 395-2129
Fax (626) 304-9834
E-mail: info@ligo.caltech.edu

Massachusetts Institute of Technology
LIGO Project – NW22-295
185 Albany St. Cambridge, MA 01239
Phone (617) 253-4824
Fax (617) 253-7014
E-mail: info@ligo.mit.edu

Contents

PREFACE	2
1. INTRODUCTION	2
2 HAZARDS	11
2.1 Nominal Hazard Zone	11
3. CONTROLS	13
3.1 Access and Administrative Controls	13
3.2 Physical Controls: Exposure Control	13
3.3 Physical Controls: Electrical Controls.....	16
3.4 Eye Protection.....	18
4. OPERATING PROCEDURES	19
4.1 Responsible Laser Operator	19
4.2 PSL Start-up Procedures	19
4.3 Shutdown Procedures	19
5. TRAINING	21
6. RESPONSIBILITIES	21
7. REFERENCES	22

PREFACE

Table of Documentation Hierarchy

Tier 1 = M950046 (LIGO Laboratory System Safety Plan)

Tier 2 = M960001 (LIGO Laser Safety Program)

Tier 3 = M1000228 (LLO Laser Safety Plan) (Site-specific)

Tier 4 = Site-specific, laser-specific SOPs, FMEAs, and special procedures

Tier 5 = Operating, user, or other technical manuals from the manufacturer

Tier 6 = Wiki entries instructing operators "how-to".

This document is for individuals who require basic knowledge about this laser equipment. It is not a substitute for operating manuals or for one-on-one training. Standard operating procedures (SOPs) are site-specific and equipment-specific documents that fall under the jurisdiction of the site laser safety officer. Candidate laser operators must read and understand all site-specific laser safety plans as well as laser-specific SOPs. Candidate laser operators must understand that reading this documentation is necessary, but does not automatically qualify personnel to work on this laser equipment. Neither does it clear anyone to operate identical hardware at any other LIGO location.

1. INTRODUCTION

The LIGO Livingston Observatory Enhanced LIGO 35 Watt pre-stabilized laser (PSL) is a class 4 Nd:YVO₄ diode-pumped device used as the primary light source for the LIGO Livingston Observatory. This unit was built by Laser Zentrum Hannover e.V. and produces 35 Watts of continuous wave radiation at 1.064 microns. The laser emissions are “pre-stabilized” in frequency and intensity prior to reaching the input/output optics (IOO) portion of LIGO, which further filters the emissions for interferometer use. The output from the laser is in the near infrared and is therefore not visible without infrared viewing equipment such as IR cards or IR viewers.

The device itself is comprised of two main components. The master oscillator and power amplifier (MOPA) sits on the Pre-Stabilized Laser (PSL) table contained within the Large Vacuum Enclosure Area (LVEA). The second component called the Pump Laser Diodes (PLD) is stored in the Laser Diode Room (LDR). The LDR is currently located in the short term storage bay. Their respective locations are shown in Figure 1.

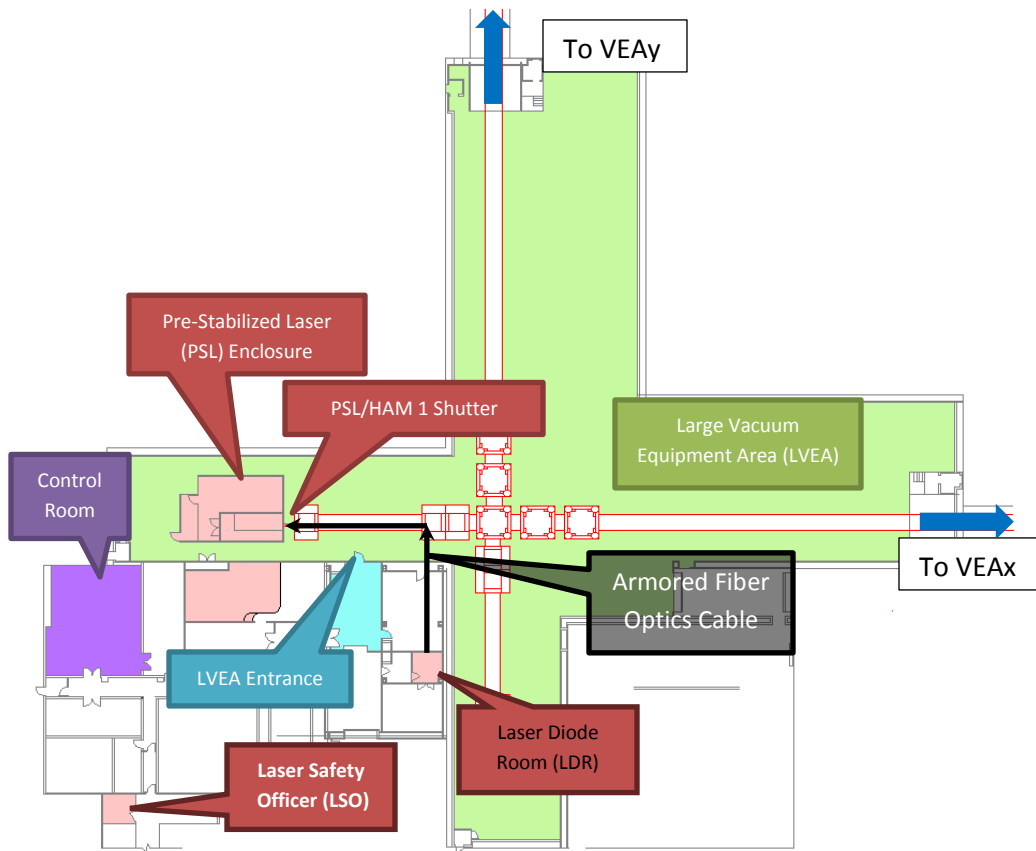

Figure 1: Location of the PSL table (enclosure and room not shown) and the LDR. The black line depicts the optical fiber path from the LDR to the PSL.

Below Figure 2 shows a magnified view of the PSL enclosure floor plan, nominal hazard zones (NHZs), and Figure 3 shows a magnified view of the LDR floor plan.

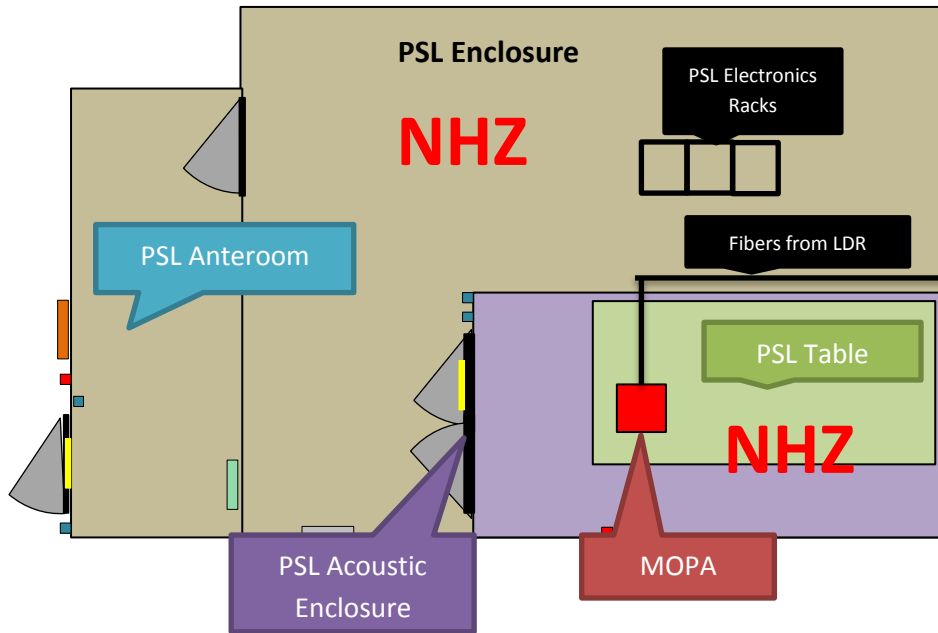

Figure 2: Pre-Stabilized Laser (PSL) floor plan. This figure points out the location of the MOPA on the PSL (optical) table and the position of the PSL electronics racks.

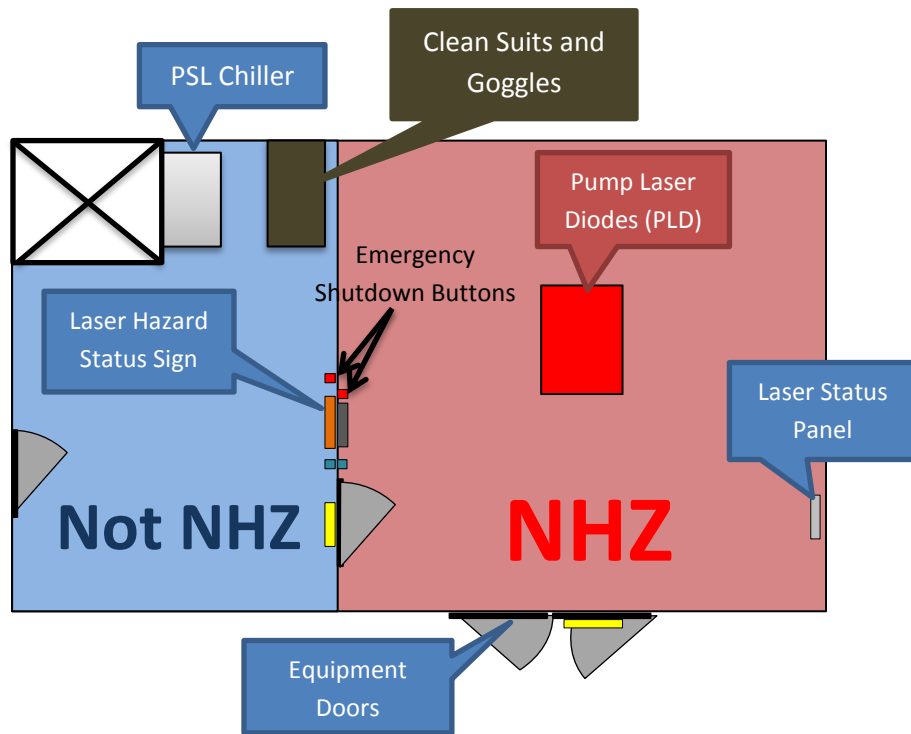

Figure 3: Laser Diode Room (LDR) floor plan. This figure points out features of the LDR gowning room and NHZ.

The MOPA is comprised of two subcomponents: the master oscillator and an amplifier. The master oscillator is an Innolight Mephisto non-planar ring oscillator (NPRO) laser. This Nd:YAG based device develops 2 Watts of continuous wave light that is directed into the power amplifier stage. The power amplifier consists of four end-pumped Nd:YVO₄ crystals. The pump radiation for these crystals is 808 nm laser light originating in the LDR. The rated maximum output following the amplifier stage is 50 W. Up to 30 mW of 808 nm radiation transmits through the MOPA aperture. High power 808 nm radiation is accessible only when the pump fibers are removed from the MOPA. Figure 4 is a photo of the MOPA's internal structure.

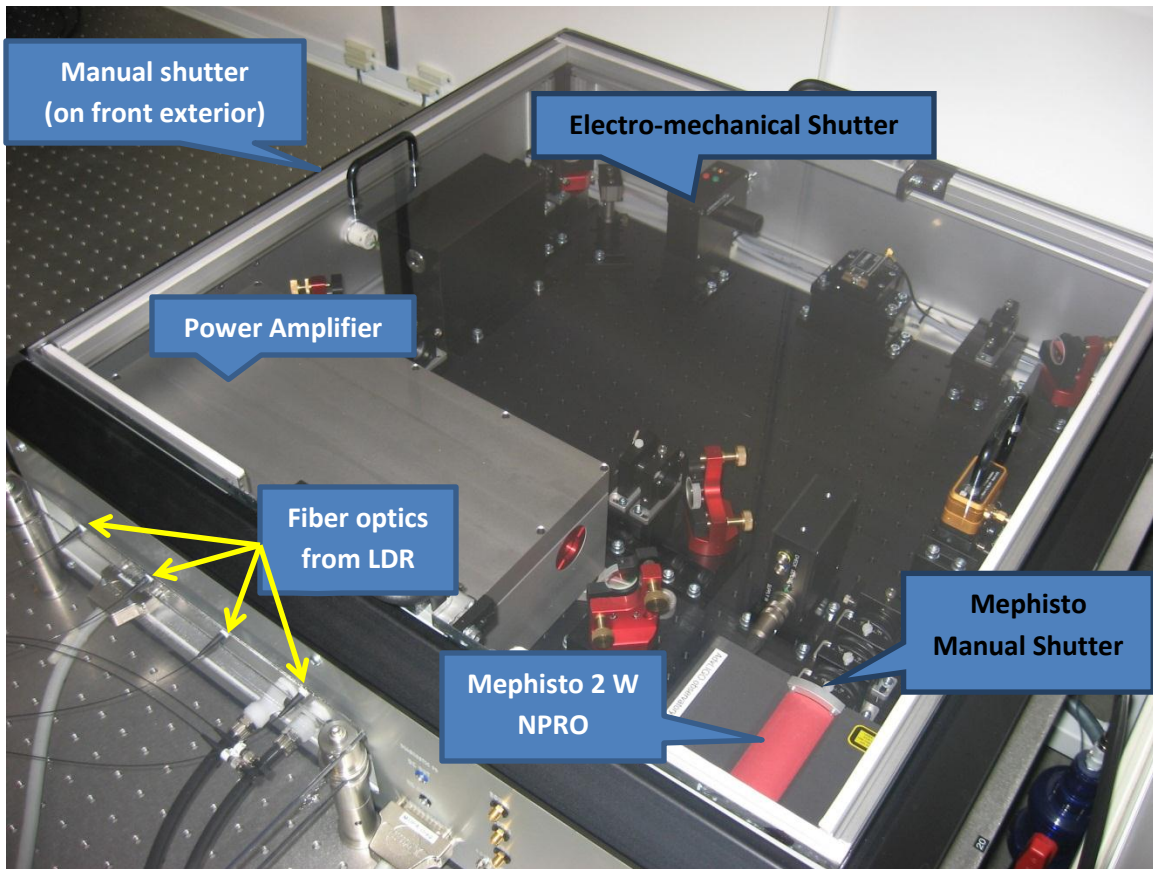

Figure 4: The MOPA's internal structure on the LIGO Livingston PSL table.

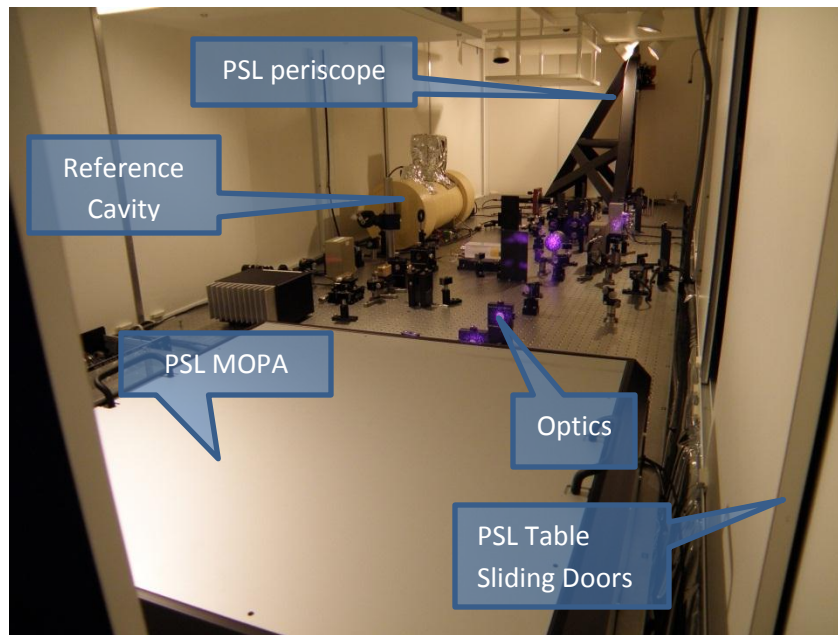

Figure 5: A photograph of the PSL table a seen from the MOPA's angle. Notice in this picture the MOPA has an opaque cover. The purple glow comes from infrared radiation registering on the camera's CCD.

Auxiliary optics and hardware exist within the MOPA. These articles serve as relay optics, power control stages, frequency stabilization stages, or diagnostic equipment. The MOPA is water cooled by a chiller found in the LDR gowning room (see Figure 3 and Figure 8).

The Mephisto's power supply is currently located in the PSL electronics racks adjacent the PSL acoustic enclosure. A key switch on the lower left of the front panel controls power supply activation. Figure 6 shows photos of the front panel of the installed Mephisto power supply.

The Beckhoff Automation touch screen (see Figure 6) is the control panel for the entire PSL laser system and is currently found in the PSL electronics racks in the PSL enclosure (see Figure 2).

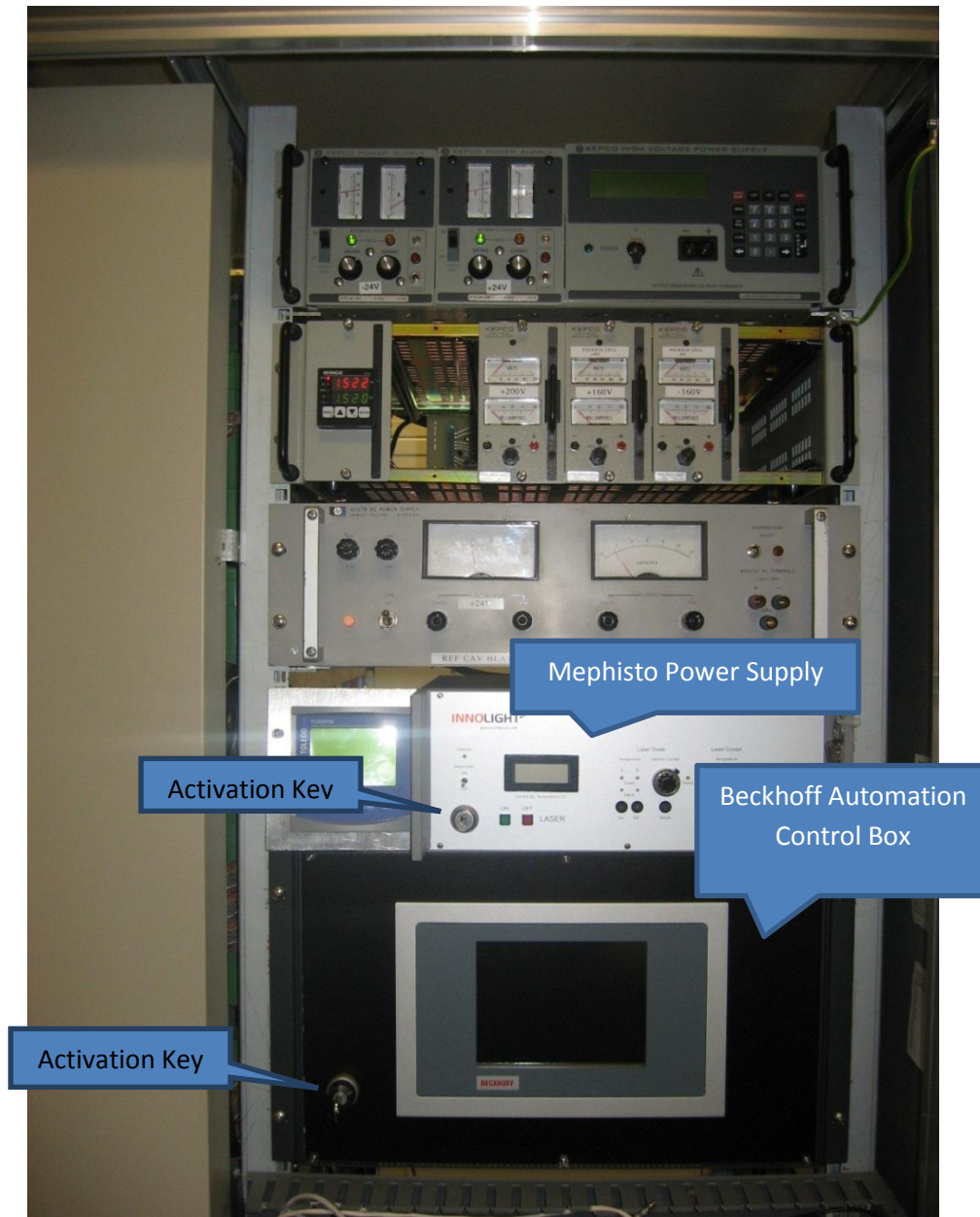

Figure 6: A photograph showing the front panels of the installed PSL Beckhoff Automation control box and Mephisto power supply. Both devices are located in the PSL room.

Figure 7 shows front and rear photos of the PLD box found in the LDR's 19 inch rack. The PLDs deliver 808 nm laser radiation through an armored optical fiber relay connecting the LDR to the PSL. The four pump diodes deliver 45 W each at 808 nm to the PSL to energize the MOPA power amplifier stage. The diode lasers enclosed are water cooled and monitored by Fieldbus modules. Cooling water is supplied by a closed loop system. The PSL/LDR chiller itself is a ThermoFlex 1400 unit built by Thermo-Fisher Scientific.



Figure 7: The pump laser diode (PLD) box front and rear view.

Figure 8 shows where the chiller is located in the LDR gowning room outside the NHZ.

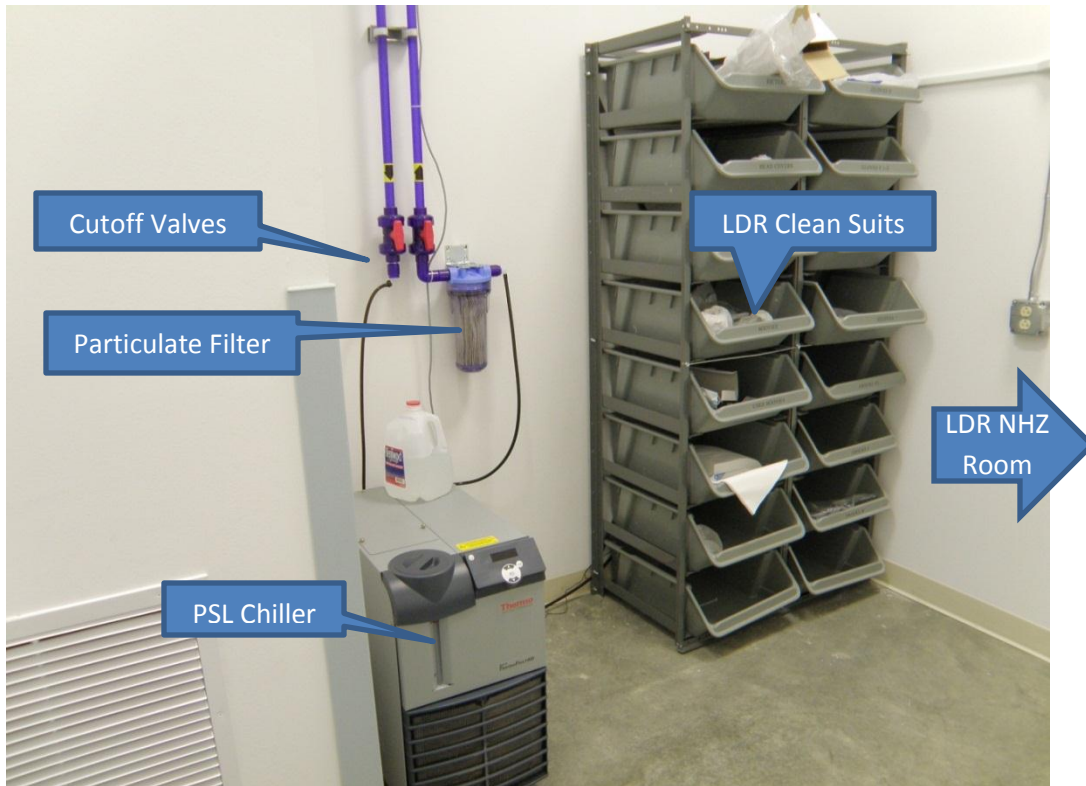

Figure 8: The PSL chiller in the LDR gowning rooms.

The parameters for the primary output of the MOPA are listed in table 1.

Table 1: Laser parameters

Description	Value/Designation
Laser Type	MOPA
Class	4
Emission center wavelength	1064 nm
Emission repetition rate	Continuous Wave
Emission waist (minimum radius)	0.2 +/- 0.02 mm
Waist location	5.5 +/- 4.5 cm downstream of aperture
Beam divergence	≈1.7 mrad
Output polarization	Vertical with respect to table (s-pol)
Maximum power output	≈50 W
Interlocked	Continuously by Kantech Site Security
Authorized locations	PSL, LVEA, LDR

2 HAZARDS

- The LIGO pre-stabilized laser is a class 4 device. Exposure to the direct beam is considered hazardous to the eyes and skin. Diffuse reflections within the nominal hazard zones (NHZ) may be considered hazardous to the eyes.
- Additionally, direct beam radiation is considered a fire hazard and therefore, should only be blocked or dumped using approved hardware.
- The internal components of the electrical hardware (control box, PLD, Mephisto power supply) are electrical hazards. Any person dismantling PSL associated electronics should be aware of possible 60 Hz/120 VAC shock dangers.
- Coolant water leaks around the electrical power supplies and PSL laser equipment are also categorized as electrical shock hazards.
- Beam dumps left in the 35 W beam for extended periods of time can become hot and present a possible burn risk.

2.1 Nominal Hazard Zone

The nominal hazard zone (NHZ) for the LIGO PSL is considered to be the following:

- The PSL acoustic enclosure and table (see Figure 2)
- The PSL room including anteroom (see Figure 2)
- The LVEA when the PSL/HAM1 shutter is open (see Figure 1 and Figure 11)
- The LDR (see Figure 3)
- VEAx and VEAY when the full interferometer is operating (see Figure 9).

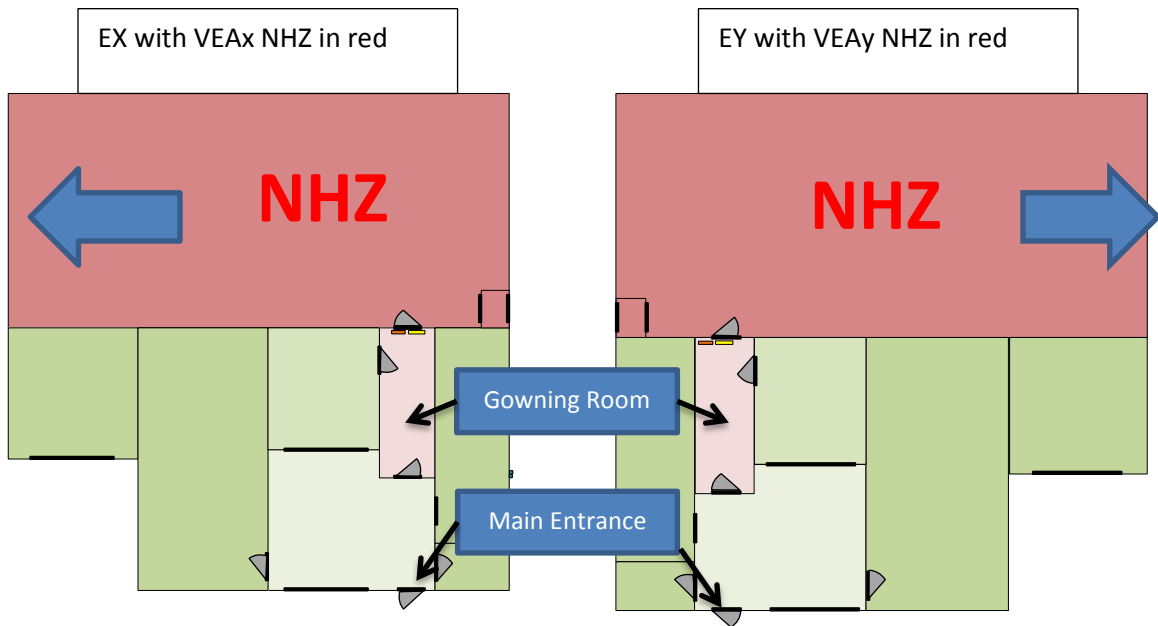

Figure 9: The VEAx and VEAY NHZs are shown in these floor plans. The blue arrows show relative directions towards the LVEA.

3. CONTROLS

3.1 Access and Administrative Controls

The access to all of the PSL direct beams is controlled to ensure site personnel laser safety. Access to the LVEA, PSL room, PSL acoustic enclosure, and the LDR is restricted to qualified laser operators. These individuals gain access to these NHZs by individualized key cards via key card readers interlocked with door latches. People who are not qualified laser operators must be escorted by qualified laser operators at all times. Also, all operations in the PSL, LVEA, VEAx, VEAY, and LDR must follow LIGO work permit procedures.

Lighted warning signs are found at access points of each associated NHZ and indicate either a “Laser Hazard” or “Laser Safe” condition. These locations are as follows:

- 1) Main LVEA personnel door,
- 2) PSL room entrance door,
- 3) PSL acoustic enclosure door,
- 4) LDR access door inside the gowning room,
- 5) Large airlock door to LVEA,
- 6) Gowning rooms at end stations,
- 7) And the control room hazard panel.

Permanent warning signs are placed on the emergency doors for the LVEA VEAx, and VEAY.

3.2 Physical Controls: Exposure Control

The direct beam and stray light of the LIGO Livingston MOPA is controlled by several redundant layers. A HEPA work box encloses the PSL table. The HEPA work box, when closed, is by itself sufficient to contain stray beams and scattered light. The PSL acoustic enclosure can resist direct PSL beams (see Figure 2).

Light from the LDR’s PLDs is directly routed into armored fiber relays. The radiation from the PLDs is thus contained within the fibers and the LDR.

The LIGO PSL MOPA has three shutters. The first manual shutter can be found on the Mephisto (see Figure 4). This shutter manually stops 2 W NPRO radiation from leaving the laser head. It does NOT safe MOPA head from spontaneous emissions.

A second manual shutter is located on the exterior of the box. In the closed position, this shutter will stop the MOPA’s direct beam delivered from the main aperture (see Figure 4).

The third electro-mechanical shutter is interlocked with the site safety/access card computer. This shutter sits inside the MOPA between the Mephisto and the power amplifier. Inappropriate activities, such as forcing the PSL acoustic enclosure door, will trigger this shutter (see Figure 4).

Beam dumps are used to block un-used or stray light (see Figure 10). These dumps are labeled and in all circumstances secured to their working surface.

Note: Insertion and extraction of beam dumps for the primary beam requires care due to the scale of momentarily scattered light. Beam dumps placed in high power beams for long periods of time must be either water cooled or high power plate-style beam dumps.

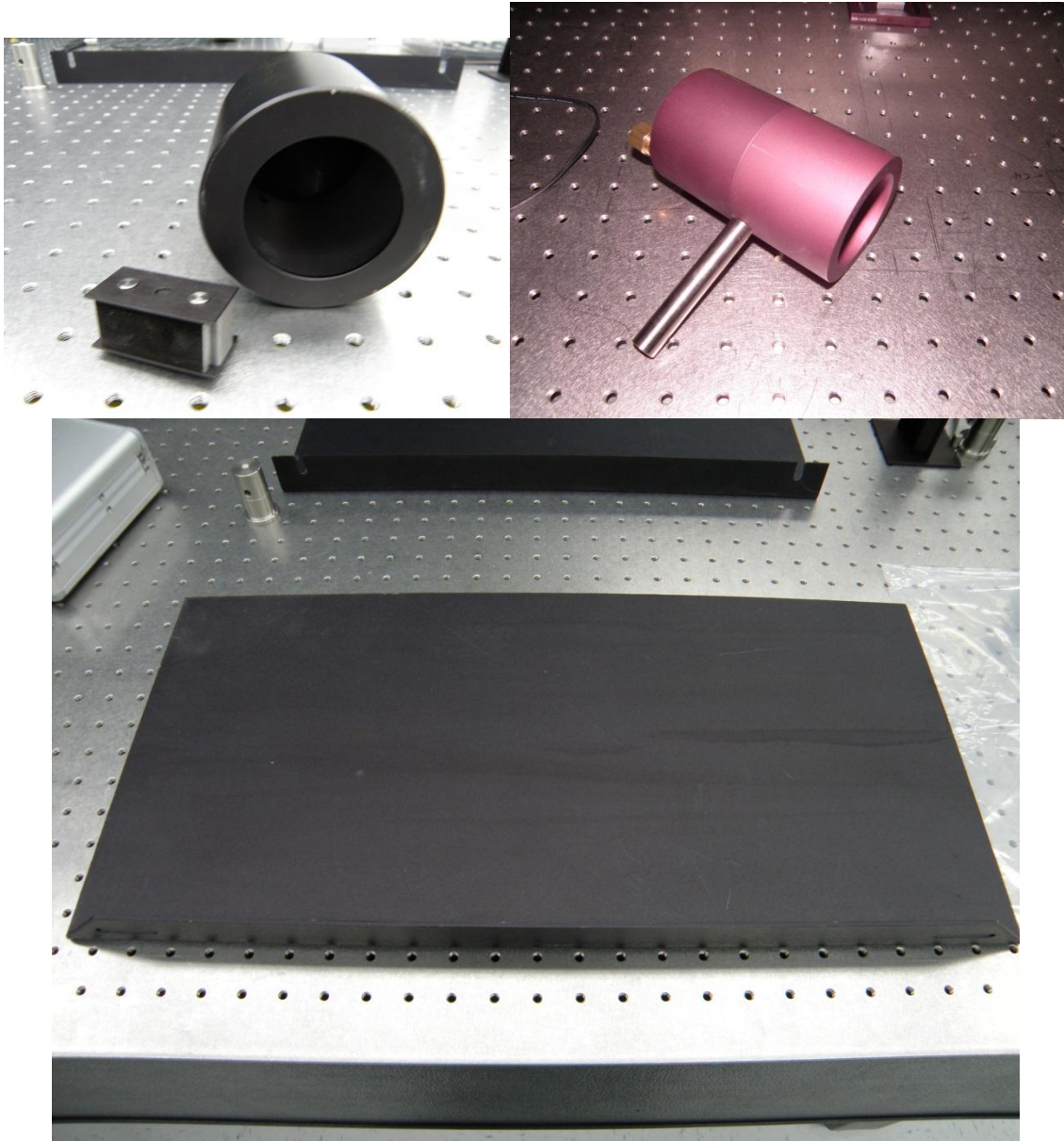

Figure 10: Beam dumps examples are shown, simple low power (upper left), water cooled style (upper right), high power plates (bottom).

A larger manual shutter is located between the PSL building and HAM 1 (see Figure 11). Closing this shutter during full power operation will not harm PSL equipment. This shutter provides a laser safe environment in the LVEA, VEAX, and VEAY if all other class 3B and 4 lasers are turned off in these NHZs and the LIGO lockout/tagout policy is followed for closing this shutter.

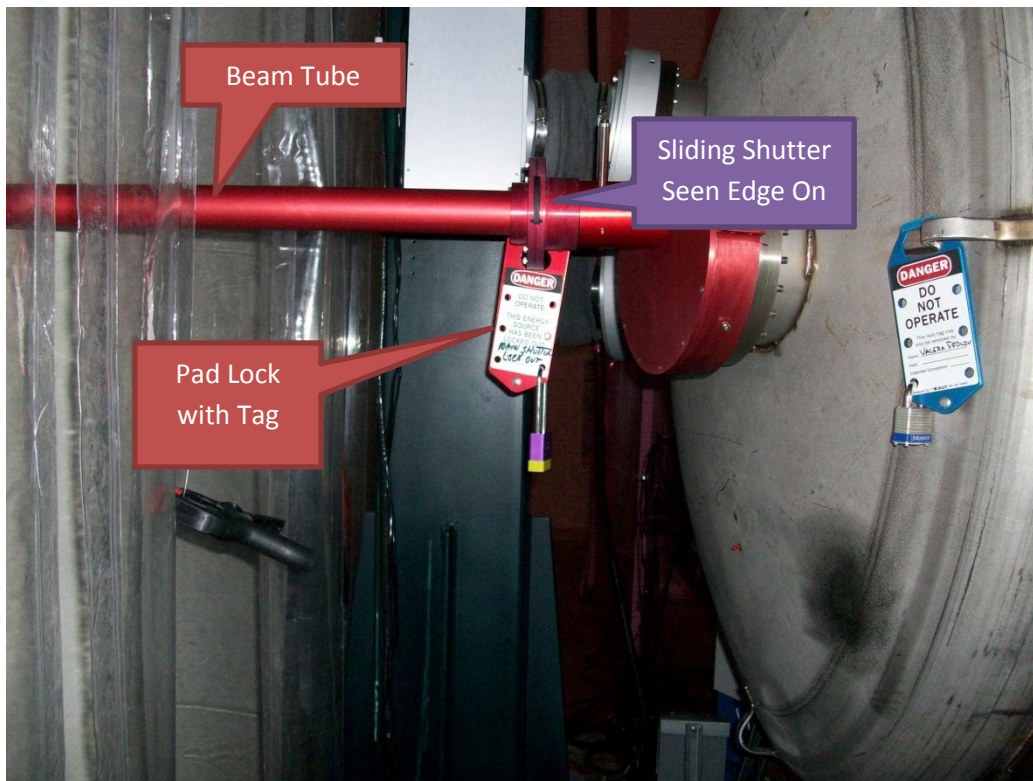

Figure 11: The PSL/HAM 1 shutter is shown in this photograph.

3.3 Physical Controls: Electrical Controls

Three hardware key interlocks prevent accidental activations of the MOPA and PLDs. The Beckhoff Automation control box is turned on by a hardware activation key shown in Figure 6. This control box also commands the PLDs found in the LDR, the MOPA, and the chiller. The InnoLight Mephisto NPRO laser power supply also must be enabled by a hardware activation key (see Figure 6). At all times, the hardware controls override the software controls. This means any key switch can disable the MOPA.

The Beckhoff control box is also interlocked and monitored by the Kantech System [the automated site safety and security system]. Forcing the PSL acoustic enclosure door or the LDR door will immediately shut down the PSL and notify the on-duty operator and laser safety officer (LSO).

An illuminated indicator is located near the MOPA output aperture. When illuminated, it indicates the presence of laser light. Other sets of status lamps in the control room, the PSL enclosure, and the LDR NHZ indicate the MOPA's laser emission state (see Figure 12).



Figure 12: An example of a status panel. The panel shown is located in the LDR NHZ.

In case of emergencies, ALL lasers in each NHZ can be shut down through the red colored “Emergency Shutdown” buttons. These buttons shut off power to all class 3B and 4 laser light sources in the LVEA and LDR NHZs providing an immediate “Laser Safe” condition. The “Emergency Shutdown” button in the LDR is shown in Figure 13.

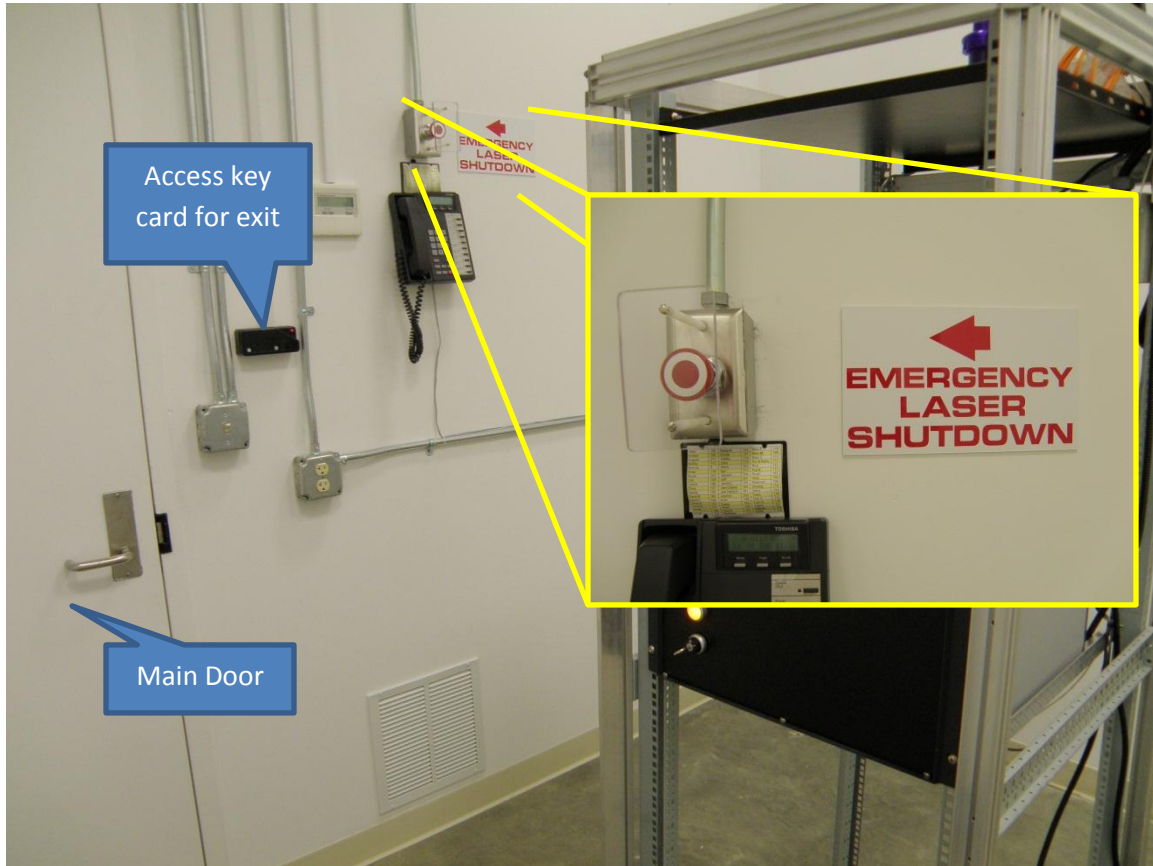

Figure 13: Location of the “Emergency Laser Shutdown” button in the LDR.

3.4 Eye Protection

All personnel working in the LVEA while the laser is capable of being or is energized must wear protective laser safety eyewear whose optical density is specified in Table 2.

Table 2: Laser safety eyewear minimum optical density (OD) for the PSL with fibers removed and LDR

Wavelength (nm)	Minimum O.D.	Beam parameters (estimate)
1064	3.87	50 W; waist = 0.18 mm
808	3.0	60 W; N.A. = 0.22

4. OPERATING PROCEDURES

4.1 Responsible Laser Operator

The Responsible Laser Operator (RLO) coordinates tasks in the PSL or LDR with the control room operator on duty. When a work permit is required it must be filed before any work begins.

Notice that the first individual who successfully enters either the PSL enclosure or the LDR NHZ is the RLO for *both* the PSL and LDR unless specified by the work permit. Access to the PSL room is handled by key card access and monitored by the status panels that are located in the PSL, LDR, and control room. These panels show whether or not these rooms are occupied and the current laser state. Others wanting access to the PSL NHZ or the LDR NHZ must contact the RLO before they enter either area.

4.2 PSL Start-up Procedures

Only qualified laser operators are permitted to activate the LIGO Livingston PSL.

The RLO is responsible for managing the *laser hazard state of the PSL enclosure and the LDR*. The RLO will confirm that no one is physically in the direct path of the beam, that the beams do not leave the PSL table except via the PSL/HAM1 beam tube, and that all personnel are wearing correct eyewear prior to powering up the laser. The RLO is required to obtain the 3 PSL activation keys from the key safe, when necessary.

The RLO is also responsible for managing the *laser hazard state of the LVEA, VEAx, and VEAy warning signs*. When a laser hazard state transition is required, the RLO and associated team members will transition the affected NHZs to laser hazard according to NHZ transition protocols and lockout/tagout policies. This means the hazard state must exist before the hazards exist. The PSL's hardware activation keys may not be inserted into the Mephisto power supply, the PLD box, or the Beckhoff Automation control box until the affected NHZs have completed the transition to laser hazard.

NOTE: *If a laser beam with power in excess of 2 mW is found (reported by any observer), leaving the optics table, the laser will be shut down by the LSO and will remain "OFF" until start-up authorization is received.*

NOTE: *It is the responsibility of each person working within the Laser Nominal Hazard Zone (NHZ) to ensure that LIGO standards for safe laser operation are being followed at all times*

4.3 Shutdown Procedures

Only qualified laser operators are permitted to deactivate the LIGO Livingston PSL in a controlled manner. (Any person may deactivate the laser in an emergency.)

The RLO is responsible for coordinating PSL shut downs with the on-duty control room operator. The RLO is responsible for filing a work permit, when necessary to perform this activity. For extended PSL shutdown periods, the RLO is also responsible for managing the laser hazard status of the associated NHZs.

The controlled shut down of the PSL must be performed using the Beckhoff control panel. This control box correctly cycles the PLDs, Mephisto, and chiller preparing them to be shut down.

All 3 activation keys must be placed in the key safe in the control room when safing the PSL for extended periods of time.

NOTE: *Turning off the PSL and removing the activation keys IS NOT sufficient to transition associated NHZs to laser safe status.*

NOTE: *In cases of emergency, any person may shut down the PSL via any of the Emergency Laser Shutdown buttons located in the LVEA, LDR, PSL enclosure, or control room.*

5. TRAINING

LIGO basic laser safety training must be completed before any individual can work around any class 3B and/or class 4 laser emission.

Access to the PSL enclosure and the LDR is only on an “as needed” basis for qualified laser operators. To become a qualified laser operator, an individual must complete the following requirements.

1. Received LIGO basic laser safety training
2. Have a full understanding of this SOP and its associated FMEA
3. Understand emergency and safety procedures
4. Received authorization from the LIGO Livingston laser safety officer

NOTE: *Training on any specific laser system does not automatically qualify individuals for other lasers at the LIGO facilities and associated university labs.*

6. RESPONSIBILITIES

- Each person working with the LIGO PSL is responsible for ensuring that safe laser practices are being followed at all times.
- The responsible laser operator is responsible for the conducting tasks on a specific laser system in accordance with the prescribed control measures and in compliance with this SOP.
- The responsible laser operator is responsible for informing any and all assisting personnel regarding the control measures and SOP for the specific laser system.
- The responsible laser operator shall be responsible for any communications with other site personnel regarding changes in the operational status of the specific laser system.
- In case of safety incidents, contact the immediate personnel and (if necessary) emergency medical services as soon as possible.
- Any identified flaws in procedures or potential improvements that could enhance safety should be brought to the attention of the LLO Laser Safety Officer or cognizant laser personnel.

7. References

- American National Standard for Safe Use of Lasers, ANSI Z136.1-2007
Laser Institute of America, ISBN 0-912035-65-X
- LIGO-M950046 (LIGO Laboratory System Safety Plan)
- LIGO-M960001 (LIGO Laser Safety Program)
- LIGO-M1000228 (LLO Laser Safety Plan)
- LIGO-M0900241 (Laser Safety Training for Certification and Recertification of LIGO Personnel)
- LIGO-M080368 (LLO NHZ Transition Procedures)
- LIGO-G0901007 (LIGO Basic Laser Safety Training Presentation)
- LIGO-G1000017 (LLO Addendum to Basic Laser Safety Training)